

PHILIPS

Data handbook



Electronic
components
and materials

Components and materials

Part 3 January 1977

Radio

Audio

Television

COMPONENTS AND MATERIALS

Part 3

January 1977

FM tuners	A	
Loudspeakers	B	
Television tuners and aerial input assemblies	C	
Components for black and white television	D	
Components for colour television	E	
Contents		

FOR "FERRITES FOR RADIO, AUDIO AND TELEVISION"
SEE RELEVANT SECTION OF PART 4a

DATA HANDBOOK SYSTEM

Our Data Handbook System is a comprehensive source of information on electronic components, subassemblies and materials; it is made up of three series of handbooks each comprising several parts.

ELECTRON TUBES

BLUE

SEMICONDUCTORS AND INTEGRATED CIRCUITS

RED

COMPONENTS AND MATERIALS

GREEN

The several parts contain all pertinent data available at the time of publication, and each is revised and reissued periodically.

Where ratings or specifications differ from those published in the preceding edition they are pointed out by arrows. Where application information is given it is advisory and does not form part of the product specification.

If you need confirmation that the published data about any of our products are the latest available, please contact our representative. He is at your service and will be glad to answer your inquiries.

This information is furnished for guidance, and with no guarantee as to its accuracy or completeness; its publication conveys no licence under any patent or other right, nor does the publisher assume liability for any consequence of its use; specifications and availability of goods mentioned in it are subject to change without notice; it is not to be reproduced in any way, in whole or in part without the written consent of the publisher.

ELECTRON TUBES (BLUE SERIES)

This series consists of the following parts, issued on the dates indicated.

Part 1a	Transmitting tubes for communication and Tubes for r.f. heating Types PE05/25 - TBW15/125	December 1975
Part 1b	Transmitting tubes for communication Tubes for r.f. heating Amplifier circuit assemblies	January 1976
Part 2	<div style="display: flex; justify-content: space-between;"> <div style="width: 45%;"> Microwave products Communication magnetrons Magnetrons for microwave heating Klystrons Travelling-wave tubes </div> <div style="width: 45%;"> Diodes Triodes T-R Switches Microwave semiconductor devices Isolators - circulators </div> </div>	May 1976
Part 3	Special Quality tubes; Miscellaneous devices	January 1975
Part 4	Receiving tubes	March 1975
Part 5a	Cathode-ray tubes	August 1976
Part 5b	Camera tubes; Image intensifier tubes	May 1975
Part 6	Products for nuclear technology Channel electron multipliers Geiger-Mueller tubes Neutron tubes	January 1977
Part 7	Gas-filled tubes Voltage stabilizing and reference tubes Counter, selector, and indicator tubes Trigger tubes Switching diodes	August 1975
Part 8	TV Picture tubes	October 1975
Part 9	Photomultiplier tubes Phototubes (diodes)	June 1976

SEMICONDUCTORS AND INTEGRATED CIRCUITS (RED SERIES)

This series consists of the following parts, issued on the dates indicated.

Part 1a	Rectifier diodes, thyristors, triacs		March 1976
	Rectifier diodes	Rectifier stacks	
	Voltage regulator diodes (> 1,5 W)	Thyristors	
	Transient suppressor diodes	Triacs	
Part 1b	Diodes		October 1975
	Small signal germanium diodes	Voltage regulator diodes (< 1,5 W)	
	Small signal silicon diodes	Voltage reference diodes	
	Special diodes	Tuner diodes	
Part 2	Low-frequency transistors		December 1975
Part 3	High-frequency and switching transistors		April 1976
Part 4a	Special semiconductors		June 1976
	Transmitting transistors	Dual transistors	
	Microwave devices	Microminiature devices for	
	Field-effect transistors	thick- and thin-film circuits	
Part 4b	Devices for optoelectronics		July 1976
	Photosensitive diodes and transistors	Photocouplers	
	Light emitting diodes	Infrared sensitive devices	
	Displays	Photoconductive devices	
Part 5a	Professional analogue integrated circuits		November 1976
	N.B. Consumer circuits will be issued in part 5b		
Part 6	Digital integrated circuits		May 1976
	LOCMOS HE family		
	GZ family		

COMPONENTS AND MATERIALS (GREEN SERIES)

This series consists of the following parts, issued on the dates indicated.

Part 1	Functional units, Input/output devices, Peripheral devices	November 1975
	High noise immunity logic FZ/30-Series Circuit blocks 40-Series and CSA70 Counter modules 50-Series NORbits 60-Series, 61-Series	Circuit blocks 90-Series Input/output devices Hybrid integrated circuits Peripheral devices
Part 2a	Resistors	February 1976
	Fixed resistors Variable resistors Voltage dependent resistors (VDR) Light dependent resistors (LDR)	Negative temperature coefficient thermistors (NTC) Positive temperature coefficient thermistors (PTC) Test switches
Part 2b	Capacitors	April 1976
	Electrolytic and solid capacitors Paper capacitors and film capacitors	Ceramic capacitors Variable capacitors
Part 3	Radio, Audio, Television	January 1977
	FM tuners Loudspeakers Television tuners and aerial input assemblies	Components for black and white television Components for colour television
Part 4a	Soft ferrites	October 1976
	Ferrites for radio, audio and television Beads and chokes	Ferroxcube potcores and square cores Ferroxcube transformer cores
Part 4b	Piezoelectric ceramics, Permanent magnet materials	December 1976
Part 5	Ferrite core memory products	July 1975
	Ferroxcube memory cores Matrix planes and stacks	Core memory systems
Part 6	Electric motors and accessories	September 1975
	Small synchronous motors Stepper motors	Miniature direct current motors
Part 7	Circuit blocks	September 1971
	Circuit blocks 100 kHz-Series Circuit blocks 1-Series Circuit blocks 10-Series	Circuit blocks for ferrite core memory drive
Part 8	Variable mains transformers	July 1975
Part 9	Piezoelectric quartz devices	March 1976
Part 10	Connectors	November 1975



F.M. tuners

F.M. TUNER with diode tuning

QUICK REFERENCE DATA	
Supply voltage (d. c.)	15 V
Frequency range	87,5 - 108 MHz
Intermediate frequency	10,7 MHz

APPLICATION

This tuner is intended for use in hi-fi radio sets.
The required range can be obtained by limiting the tuning voltage.
The tuners are provided with a four-fold i. f. circuit.

MECHANICAL DATA

Dimensions in mm

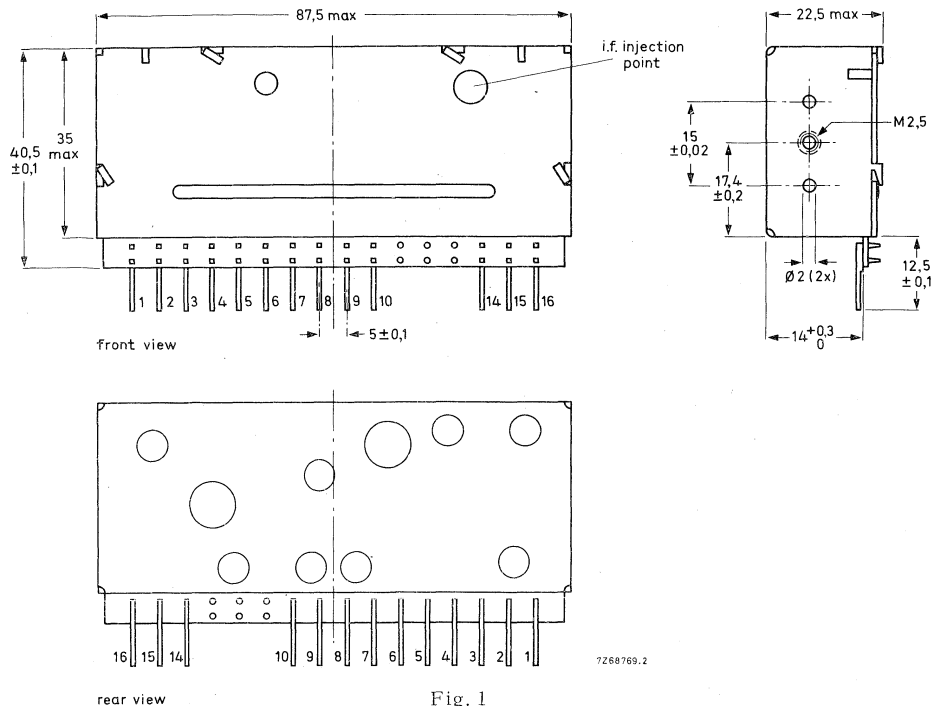

Fig. 1

Note : The left and right sides are identical.

Mounting

The tuner can be mounted in any position.

Marking

The tuner is marked with the 12-digit catalogue number and the production code.

ELECTRICAL DATA

Unless otherwise specified all electrical values apply at an ambient temperature of 25 ± 5 °C, a relative humidity of $60 \pm 15\%$ and a supply voltage of 15 ± 1 V.

Semiconductors

r. f. amplifier	BF324
mixer	BF324
oscillator	BF324
tuning diodes	BB110B (2x), BB110G

Ambient temperature range

operating	0 to +55 °C
storage	-20 to +70 °C

Supply voltage (d. c.)

+15 ± 1 V

Current drawn from +15V supply

8,75 ± 0,5 mA

Tuning voltage range

+3 to +27 V

Frequency range

87,5 to 108 MHz

voltage (V d. c.)	frequency (MHz)	
3,00	87	} ±300 kHz
3,30	88	
4,00	90	
4,80	92	
5,80	94	
6,95	96	
8,35	98	

voltage (V d. c.)	frequency (MHz)	
10,05	100	} ±300 kHz
12,10	102	
14,65	104	
17,80	106	
21,80	108	
27,00	110	

Intermediate frequency

10,7 MHz

The oscillator frequency is higher than the signal frequency

I. F. bandwidth (3 dB)

180 kHz

S 300

typ. 27 dB

Input impedance, asymmetrical

75 Ω

Output impedance

300 Ω

Padding deviation

≤ 350 kHz

Power gain

typ. 20 dB

Noise figure

typ. 6,5 dB

I. F. suppression

≥ 80 dB

Image rejection

≥ 50 dB

Repeat spot suppression (RSS) ¹⁾	≥ 75 dB
Double beat suppression (DBS) ²⁾	≥ 75 dB
Continuous beat suppression (CBS) ³⁾	≥ 60 dB
Shift of oscillator frequency	
at a change of the supply voltage	
from 15 to 12 V	≤ 100 kHz
at a change of the ambient temperature	
from 0 to +55 °C	≤ 5 kHz/°C; typ. 2,5 kHz/°C
after resistance to moisture test	
(IEC 68-2-30, test Db, 21 days, 40 °C;	
recovery time 1 h)	≤ 1250 kHz; typ. 600 kHz
Reduction of power gain at a change of the	
supply voltage from 15 to 12 V	≤ 3.5 dB
Oscillator radiation and oscillator	
terminal voltage	according to C.I.S.P.R. recommen- dation no. 24/3; measured according to I.E.C. 106.

¹⁾ Suppression of a signal arising by conversion of harmonics of the oscillator signal and those of a strong aerial signal. Reference voltage: 10 μV (aerial e. m. f.); aerial impedance: 75 Ω.

²⁾ Suppression of a signal arising from two strong aerial signals. Reference voltage: 10 μV (aerial e. m. f.); aerial impedance: 75 Ω.

³⁾ Suppression of a signal arising from the harmonic of two strong aerial signals with a frequency difference equal to the intermediate frequency.

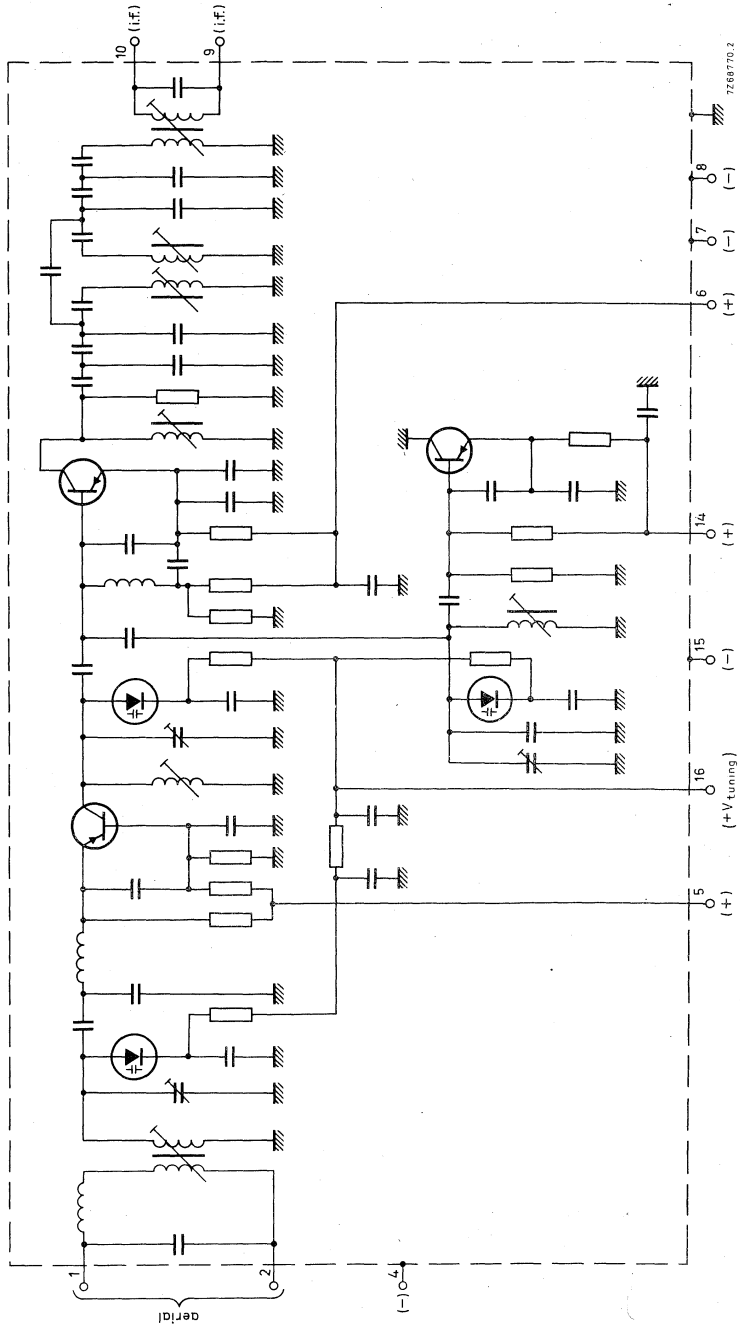

Fig. 2



ADDITIONAL INFORMATION

Aligning of the i. f. circuit

The tuner is fully h.f. and i.f. aligned in the factory.

However, if an adaptation to the receiver is necessary, aligning should be done in the following way.

1. Adjust the tuning voltage to +8,35 V.
2. Apply a generator signal (≤ 100 mV, $10,7$ MHz ± 2 kHz) to the i. f. injection point (Fig. 1) via the circuit shown in Fig. 3.

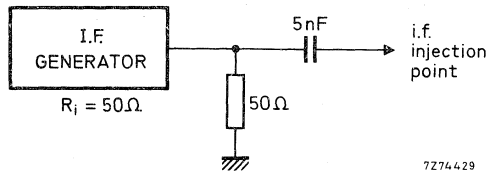
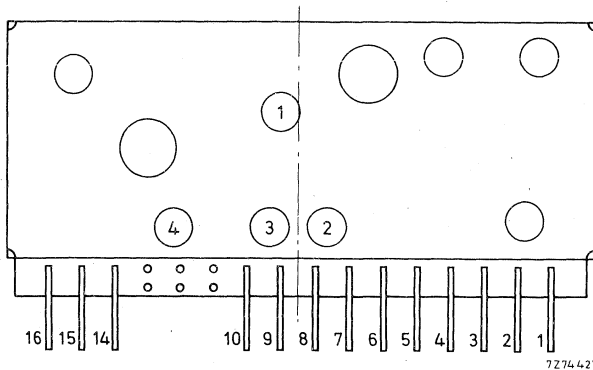

Fig. 3

3. Adjust the i. f. coils in sequence 1 to 4 (Fig. 4) to maximum output.



rear view

Fig. 4

4. Apply a generator signal (100 mV, $10,7$ MHz ± 500 kHz) to the i. f. injection point for checking the i. f. bandwidth; top of the curve at $10,7$ MHz ± 5 kHz. Check the i. f. bandwidth (3 dB) and S 300: their values must be as specified in "Electrical Data".

Measurement of power gain

Fig. 5

The r. f. input signal: ≤ 1 mV (r. m. s.)

The gain = $20 \log \frac{\text{i. f. voltage across } R (= 390 \Omega)}{\text{aerial e. m. f.}}$

F.M. TUNER with diode tuning

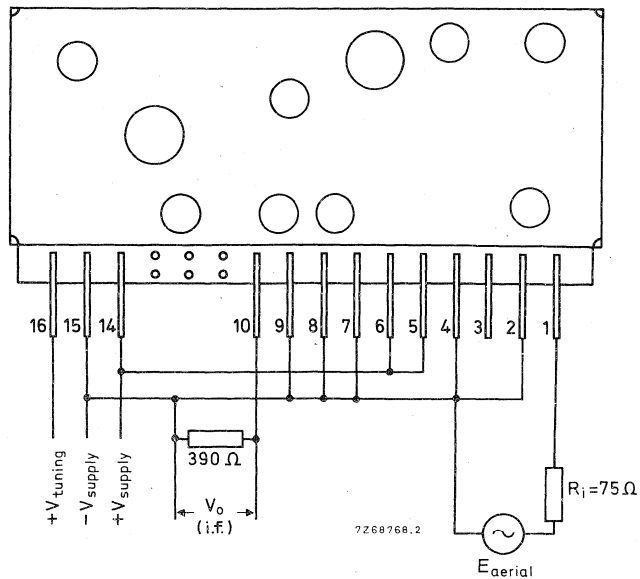
QUICK REFERENCE DATA

Supply voltage (d. c.)	15 V
Frequency range	87,5 - 108 MHz
Intermediate frequency	10,7 MHz

APPLICATION

This tuner is intended for use in hi-fi radio sets.

The required range can be obtained by limiting the tuning voltage.

The tuner has been provided with a two-fold i. f. circuit.

MECHANICAL DATA

Dimensions in mm

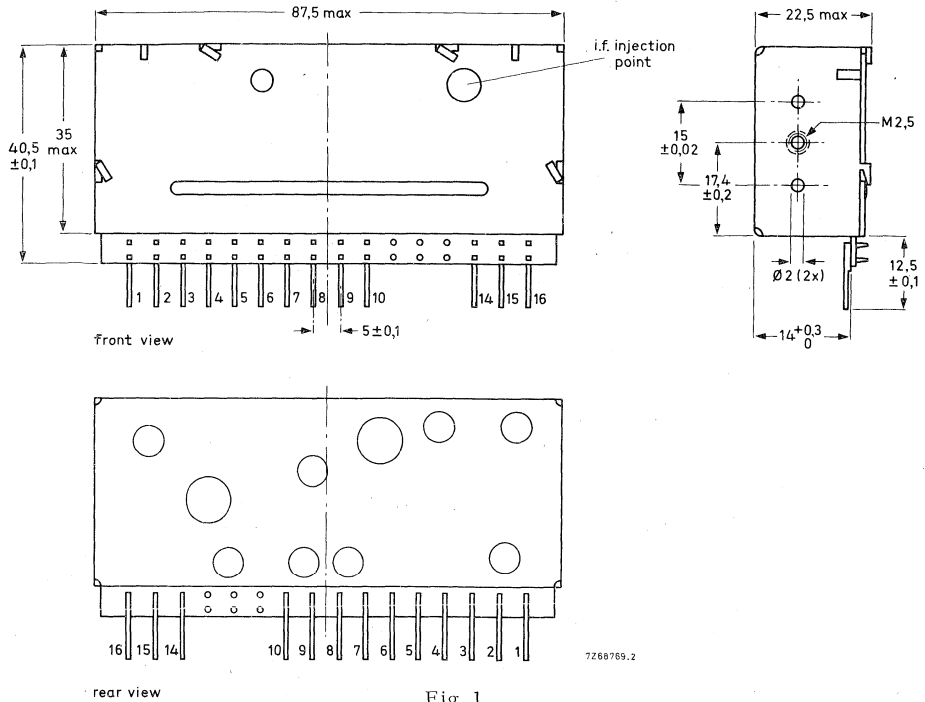

Note : The left and right sides are identical.

Mounting

The tuner can be mounted in any position.

Marking

The tuner is marked with the 12-digit catalogue number and the production code.

ELECTRICAL DATA

Unless otherwise specified all electrical values apply at an ambient temperature of 25 ± 5 °C, a relative humidity of $60 \pm 15\%$ and a supply voltage of 15 ± 1 V.

Semiconductors

r. f. amplifier	BF324
mixer	BF324
oscillator	BF324
tuning diodes	BB110B (2x), BB110G

Ambient temperature range

operating	0 to +55 °C
storage	-20 to +70 °C

Supply voltage (d. c.)

+15 \pm 1 V

Current drawn from +15 V supply

typ. 8,75 \pm 0,5 mA

Tuning voltage range

+3 to +27 V

Frequency range

87,5 to 108 MHz

voltage (V d. c.)	frequency (MHz)	
3,00	87	} \pm 300 kHz
3,30	88	
4,00	90	
4,80	92	
5,80	94	
6,95	96	
8,35	98	

voltage (V d. c.)	frequency (MHz)	
10,05	100	} \pm 300 kHz
12,10	102	
14,65	104	
17,80	106	
21,80	108	
27,00	110	

Intermediate frequency

10,7 MHz

The oscillator frequency is higher than the signal frequency

I. F. bandwidth (3 dB)

220 kHz

S 300

typ. 16 dB

Input impedance, asymmetrical

75 Ω

Output impedance

300 Ω

Padding deviation

 \leq 350 kHz

Power gain

typ. 30 dB

Noise figure

typ. 6,5 dB

I. F. suppression

 \geq 80 dB

Image rejection

 \geq 50 dB

Repeat spot suppression (RSS) ¹⁾	≥ 75 dB
Double beat suppression (DBS) ²⁾	≥ 75 dB
Continuous beat suppression (CBS) ³⁾	≥ 60 dB
Shift of oscillator frequency at a change of the supply voltage from 15 to 12 V	≤ 100 kHz
at a change of the ambient temperature from 0 to +55 °C	≤ 5 kHz/°C; typ. 2,5 kHz/°C
after resistance to moisture test (IEC 68-2-30, test Db, 21 days, 40 °C; recovery time 1 h)	≤ 1250 kHz; typ. 600 kHz
Reduction of power gain at a change of the supply voltage from 15 to 12 V	≤ 3,5 dB
Oscillator radiation and oscillator terminal voltage	according to C.I.S.P.R. recommen- dation no. 24/3; measured according to I.E.C. 106.

¹⁾ Suppression of a signal arising by conversion of harmonics of the oscillator signal and those of a strong aerial signal. Reference voltage: 10 μV (aerial e. m. f.); aerial impedance: 75 Ω.

²⁾ Suppression of a signal arising from two strong aerial signals. Reference voltage: 10 μV (aerial e. m. f.); aerial impedance: 75 Ω.

³⁾ Suppression of a signal arising from the harmonic of two strong aerial signals with a frequency difference equal to the intermediate frequency.

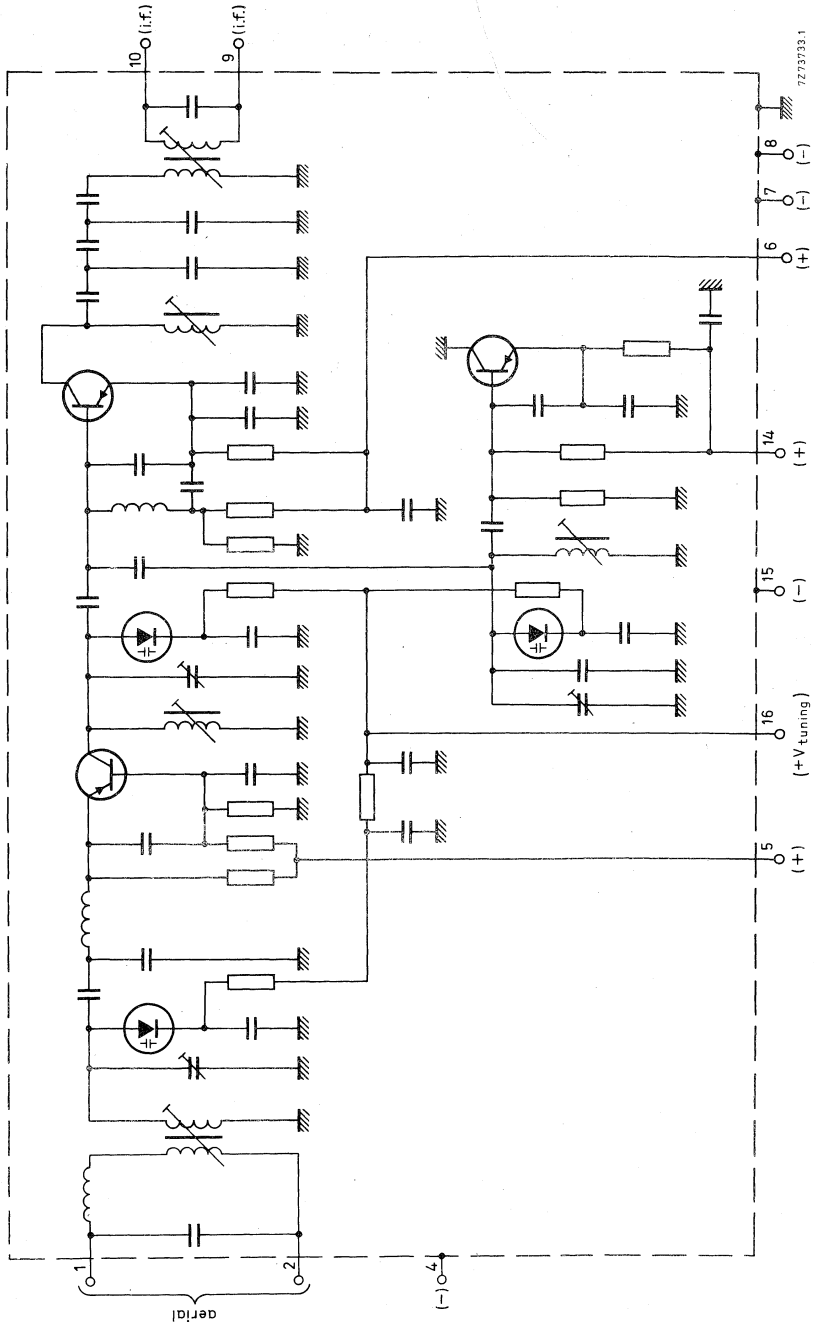

Fig. 2

ADDITIONAL INFORMATION

Aligning of the i. f. circuit

The tuner is fully h.f. and i.f. aligned in the factory.

However, if an adaptation to the receiver is necessary, aligning should be done in the following way.

1. Adjust the tuning voltage to +8,35 V.
2. Apply a generator signal (≤ 100 mV, $10,7$ MHz ± 2 kHz) to the i. f. injection point (Fig. 1) via the circuit shown in Fig. 3.

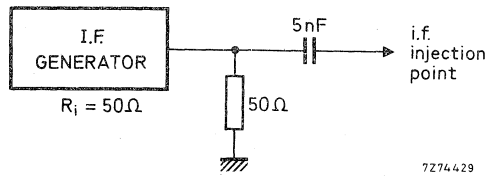
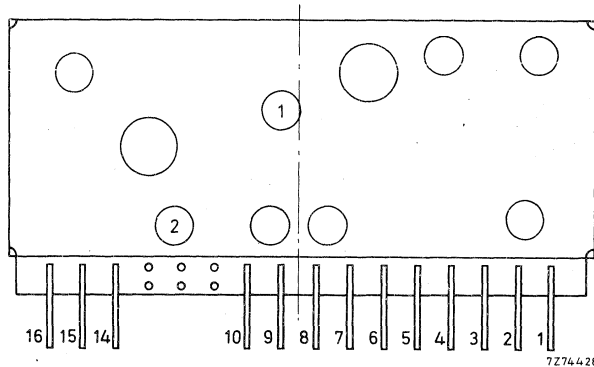

Fig. 3

3. Adjust the i. f. coils in sequence 1 to 2 (Fig. 4) to maximum output.



rear view

Fig. 4

4. Apply a generator signal (100 mV, $10,7$ MHz ± 500 kHz) to the i. f. injection point for checking the i. f. bandwidth; top of the curve at $10,7$ MHz ± 5 kHz. Check the i. f. bandwidth (3 dB) and S 300: their values must be as specified in "Electrical Data".

Measuring the power gain

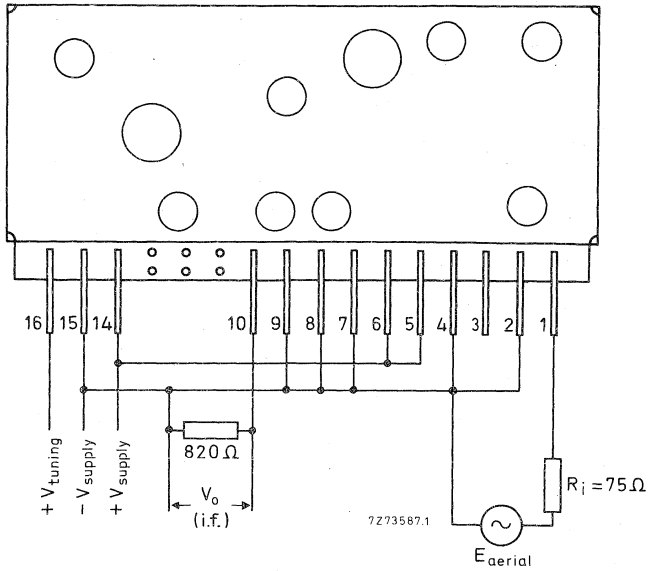

Fig. 5

The r.f. input signal: ≤ 1 mV (r. m. s.)

The gain = $20 \log \frac{\text{i. f. voltage across } R (= 820 \Omega)}{\text{aerial e. m. f.}}$

F.M. TUNERS with diode tuning

QUICK REFERENCE DATA

F.M. tuners for European and American band
Tuner FD1 without a.f.c.
Tuner FDIA with a.f.c.

Supply voltage (d.c.)

12 V

Frequency range

87,5 to 108 MHz

GENERAL

These tuners are intended for use in hi-fi radio sets. The advantage of these tuners is the excellent big signal handling.

The wanted range can be obtained by limiting the tuning voltage.

The tuners are equipped with silicon transistors and silicon variable capacitance diodes.

MECHANICAL DATA

Dimensions in mm

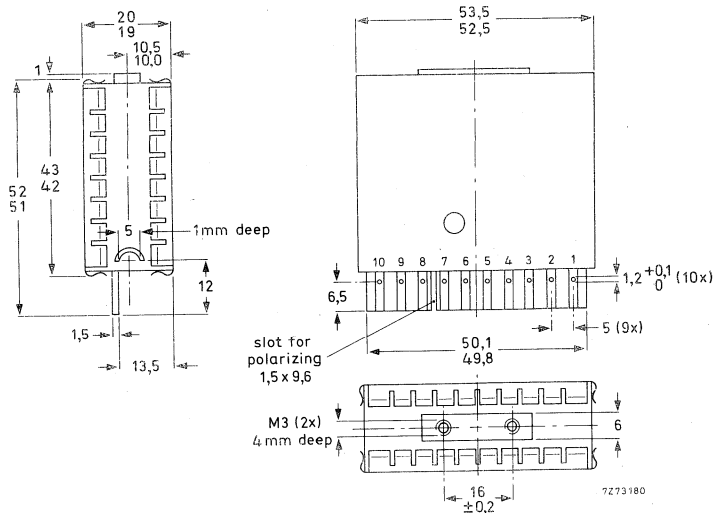

Fig. 1

The tuner can be fixed in a connector or soldered directly to a printed-wiring board.

ELECTRICAL DATA

Semiconductors	2 x BF324 1 x BF451 4 x BB104 1 x BB106 (only for FDIA)
Ambient temperature range, operating storage	0 to +50 °C -20 to +60 °C
Supply voltage	+12 ± 1 V
Current drawn from +12 V supply	9 mA
Tuning voltage range (Fig. 2)	+3,8 to +28 V
Frequency range	87,5 to 108 MHz
Intermediate frequency	10,7 MHz The oscillator frequency is higher than the signal frequency
I. F. bandwidth	270 kHz
Input impedance, asymmetrical symmetrical	60 Ω 240 Ω
Output impedance for critical coupling	470 Ω
Gain at 98 MHz	min. 27 dB (typ. 30 dB)
Noise figure at 98 MHz	max. 7,5 dB (typ. 6 dB)
Reflection factor at 98 MHz	0,35
I. F. suppression at 98 MHz	min. 76 dB (typ. 83 dB)
Image rejection at 98 MHz	min. 64 dB (typ. 72 dB)
Repeat spot suppression (RSS, Fig. 3) 1)	min. 70 dB (typ. 82 dB)
Double beat suppression (DBS, Fig. 3) 2)	min. 70 dB (typ. 80 dB)
Continuous beat suppression (CBS, Fig. 4) 3)	62 dB
Minimum input signal (e. m. f.) at a shift of the oscillator frequency of max. 20 kHz	1 V
Shift of the oscillator frequency at a change of the supply voltage of 1 V	max. 30 kHz

1) Suppression of a signal arising by conversion of harmonics of the oscillator signal and those of a strong aerial signal.

2) Suppression of a signal arising from two strong aerial signals.

3) Suppression of a signal arising from the harmonic of two strong aerial signals with a frequency difference equal to the intermediate frequency.

Temperature coefficient of the oscillator

see Fig. 5

Oscillator radiation

according to VDE 0872.7
and 0872.8

A. F. C. sensitivity (only for FD1A)

see Figs. 6 and 7

Graphs

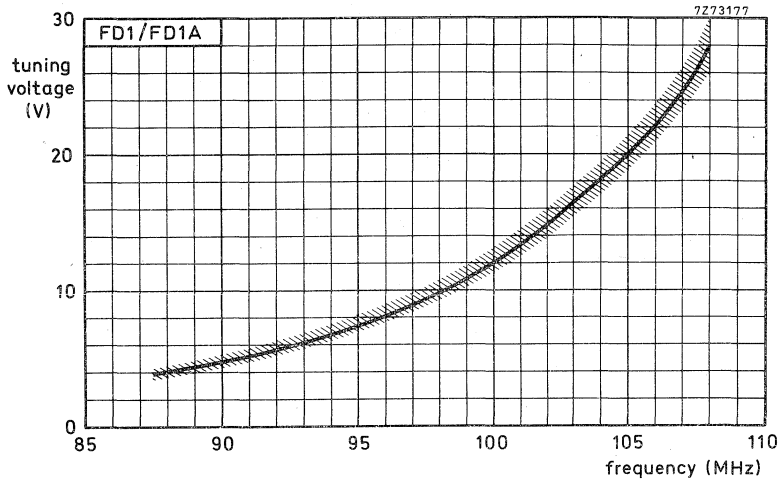

Fig. 2. Tuning voltage as a function of signal frequency.

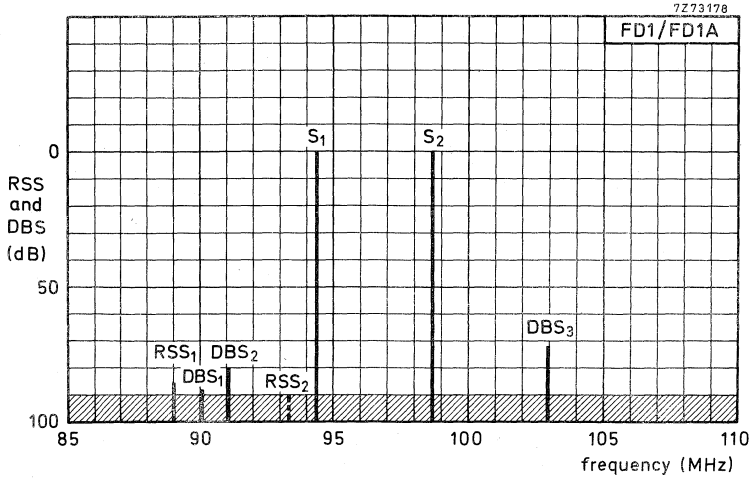

Fig. 3. Location of transmitter frequencies, repeat spots and double beats. Reference signals S₁ and S₂: 10 μV.

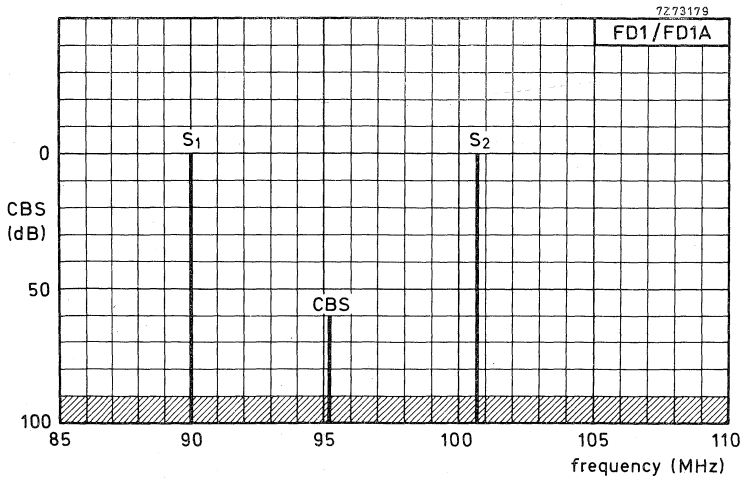

Fig. 4. Location of transmitter frequencies and measuring frequency for measuring the continuous beat suppression (CBS).

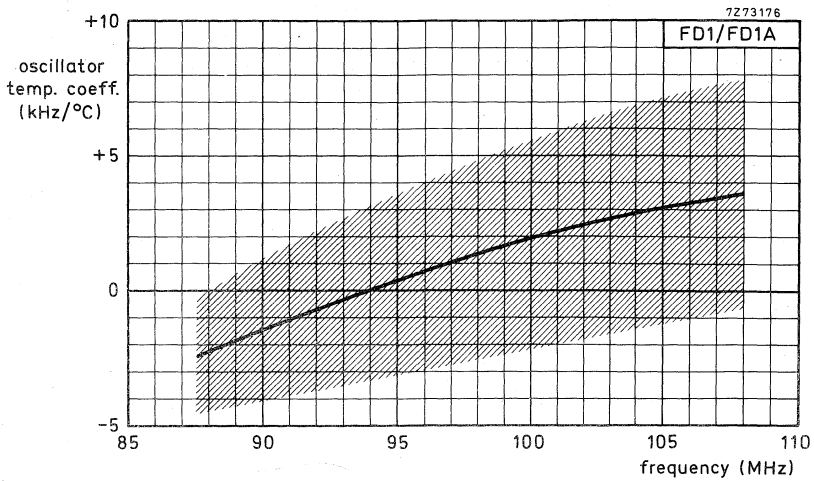

Fig. 5. Oscillator temperature coefficient as a function of signal frequency, measured in the temperature range 15 to 25 °C

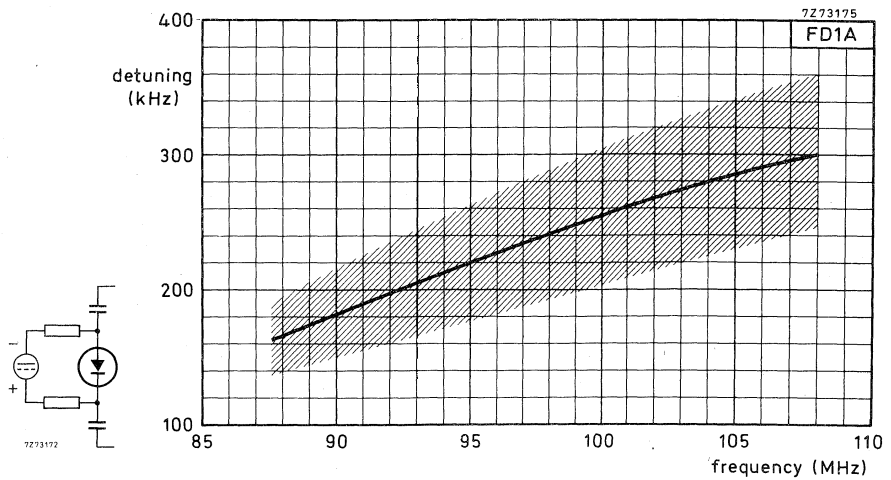

Fig. 6. Detuning as a function of signal frequency at a control voltage change from 0 to +400 mV.

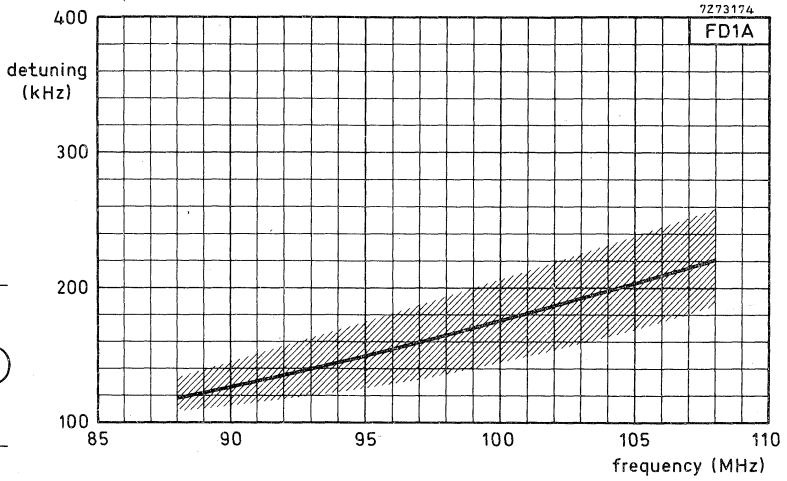

Fig. 7. Detuning as a function of signal frequency at a control voltage change from 0 to -400 mV.

Loudspeakers



Survey
Introduction
Data sheets

page B2
page B5
page B17

SURVEY

The loudspeakers are listed in order of their catalogue number. Conversion of catalogue number to type number is given in the list on page B14.

HIGH POWER (≥ 10 watt) to DIN45500 requirements for hi-fi loudspeakers

cone diameter (inches)	size		shape of flange	impedance version (Ω)	maximum power (W)	basic part of type number	page
	overall diameter (mm)						
1	94		round	4/8	20/40	AD0140/T.	B17
1	94		round	8/15	20/50	AD0162/T.	B21
2	134		round	4/8	50	AD0210/Sq.	B29
2	51		round	4/8/15	20/40	AD2090/T.	B43
2	53		square	4/8/15	20/40	AD2290/T.	B43
2 $\frac{1}{4}$	58		round	4/8	10	AD2071/T.	B37
2 $\frac{1}{4}$	58		square	4/8	10	AD2271/T.	B37
5	129		octagonal	4/8	40	AD5060/Sq.	B117
5	129		octagonal	4/8	10	AD5061/Sq.	B125
7	166		octagonal	4	40	AD7066/MFB	B173
7	166		octagonal	4/8	35	AD7066/W.	B179
8	205		octagonal	4/8	30	AD8061/W.	B201
8	205		octagonal	4/8	40	AD8066/W.	B205
8	205		octagonal	4	50	AD8067/MFB	B209
8	205		octagonal	4/8	40	AD8067/W.	B215
10	259		round	4/8	30	AD1065/W.	B235
10	261		round	4/8	40	AD10100/W.	B239
12	315		round	4/8	30	AD1265/W.	B247
12	315		round	4/8	40	AD12100/W.	B259

HIGH POWER (≥ 10 watt): FULL RANGE

5	129	octagonal	4/8	10	AD5061/M.	B121
7	166	octagonal	4/8	30	AD7060/W.	B161
7	166	octagonal	4/8	30	AD7062/M.	B165
7	166	octagonal	4/8	10	AD7063/M.	B169
8 $\frac{1}{2}$	217	round	7	10/20	9710/MC	B227
10	261	round	4/8/15	10	AD1065/M.	B231
12	315	round	4/8/15	20	AD1265/M.	B243
12	315	round	4/8	50	AD12100/HP.	B251
12	315	round	4/8/15	25	AD12100/M.	B255

MEDIUM POWER (approx.2-10 watt) double cone

cone diameter (inches)	size		shape of flange	impedance version (Ω)	maximum power (W)	basic part of type number	page
	overall diameter (mm)						
4 x 6	102 x 154		oval	4/8/25	6	AD4681/M.	B89
4 x 6	102 x 154		oval	4/8/15/25/800	4	AD4691/M.	B101
5	129		round	4/8/15/25	6	AD5081/M.	B129
5 x 7	133 x 183		oval	4/8/15/25	6	AD5780/M.	B137
5 x 7	133 x 183		oval	4/8	4	AD5790/M.	B145
6 x 9	161 x 234		oval	4/8	6	AD6980/M.	B153
7	166		octagonal	4/8	6	AD7080/M.	B183
7	166		octagonal	4/8/800	3	AD7091/M.	B191
8	206		octagonal	4/8	8	AD8081/M.	B219

MEDIUM POWER (approx.2-10 watt)

3 x 5	76 x 131		oval	4/8/15/25/50/400	3	AD3590/X.	B57
3 x 8	82 x 205		oval	4/8/15	4	AD3880/X.	B61
3 x 8	82 x 205		oval	4/8/15/25/70/800	4	AD3890/X.	B65
4	105		round	4/8/15/25	3	AD4080/X.	B73
4	105		square	4/8/15	3	AD4480/X.	B73
4	105		round	4/8	3	AD4085/X.	B77
4	105		square	4/8	3	AD4485/X.	B77
4	105		square	4	8	AD4481/X.	B85
4 x 6	102 x 154		oval	4/8/15/25	6	AD4681/X.	B93
4 x 6	95 x 155		oval	4/8/15/25	6	AD4682/X.	B97
4 x 6	102 x 154		oval	4/8/15/25	4	AD4691/X.	B105
4 x 6	95 x 155		oval	4/8/15/25	4	AD4692/X.	B109
4 x 8	96 x 210		oval	4/8/15/25	8	AD4890/X.	B113
5	129		round	4/8/15/25	6	AD5081/X.	B133
5 x 7	133 x 183		oval	4/8/15/25	6	AD5780/X.	B141
5 x 7	133 x 183		oval	4/8	4	AD5790/X.	B149
6 x 9	161 x 234		oval	4/8	6	AD6980/X.	B157
7	166		octagonal	4/8	6	AD7080/X.	B187
7	166		octagonal	4/8/800	3	AD7091/X.	B195
8	206		octagonal	4/8	8	AD8081/X.	B223

LOWER POWER (≤ 2 watt)

cone diameter (inches)	size overall diameter (mm)	shape of flange	impedance version (Ω)	maximum power (W)	basic part of type number	page
1 $\frac{1}{4}$	31	round	25	0, 2	AD0199/Z.	B25
2	50	round	25	0, 3	AD2099/Z.	B49
2 $\frac{1}{2}$	64	round	4/8/15/25	0, 5	AD2070/Z.	B33
3	81	round	4/8/15/25	1	AD3070/Y.	B53
3	81	square	4/8/25/150	1	AD3370/Y.	B53
4	105	round	4/8/15/25	1	AD4070/Y.	B69
4	105	square	4/8/15/25	1	AD4470/Y.	B69
4	105	round	8/15	2/0, 6	AD4090/X.	B81

PASSIVE RADIATOR

8	205	octagonal	-	-	AD8000	B199
---	-----	-----------	---	---	--------	------

CROSS-OVER NETWORKS

dimensions l x w x h (mm)	cross-over frequency (Hz)	impedance version (Ω)	maximum power (W)	basic part of type number	page
100 x 70 x 45	1600/1800	4/8	20	ADF 1600/.	B265
100 x 70 x 45	2400	4/8	20	ADF2400/.	B267
105 x 70 x 45	500/4500	4/8	40	ADF500/4500/.	B269

RECOMMENDED LOUDSPEAKER COMBINATIONS

Table of loudspeaker combinations see page B272.

INTRODUCTION

CHOICE OF TYPE

A correctly chosen loudspeaker is essential to obtain adequate acoustic results from electro-acoustic equipment.

The following factors should be considered when choosing a loudspeaker :

- Shape, size and attachment with reference to the available space;
- Quality and sensitivity, a compromise between fidelity of reproduction and price;
- The frequency response characteristic in relation to the kind of application;
- Impedance and power handling capacity, which should be adapted to the output stage of the equipment;
- Appearance and finish.

To assist customers in making their choice, our loudspeakers have been divided into three main groups :

- High power (≥ 10 watt) : (hi-fi/full range)
- Medium power (2 - 10 watt)
- Low power (≤ 2 watt)

The high power series comprises top-quality woofers, squawkers and tweeters intended for use in special combinations with appropriate filters and enclosures. Their excellent sound reproduction conforms in every respect to the high fidelity standards IEC 268 and DIN45500. The system power handling capacity is from 10 W to 250 W - the latter for théatres and out-door applications. Full range high power loudspeakers are also available. These speakers also conform to IEC 268 and DIN45500 but have been designed to meet somewhat less stringent requirements. They are specially for juke boxes, musical instruments, monitoring and public address systems.

The medium power series (2 W to 10 W) may be subdivided according to the application into round and oval versions, usually for radio, audio and television. Loudspeakers having a Ticonal magnet system - which keeps stray magnetic fields low - are particularly recommended for television.

The low power types (< 2 W) are mainly used in small radios, intercoms and portable television.

TYPE NUMBER SYSTEM

		ADxxxxx/xx		
<u>Nominal cone size (in inches) and shape of flange</u>			<u>Rated impedance (in Ω)</u>	
00 = 3/4	dome		<u>Version</u>	
01 = 1 to 1 1/4	dome (round)		Z	= Notably higher sensitivity around a response peak at about 3 kHz
02 = 2	dome		Y	= Notably higher response level in the region 2 to 6 kHz
10 = 10	round		X	= Same as Y, but a wider frequency range
12 = 12	round		M	= Smooth response over wide frequency range
20 = 2 to 2 1/2	round		W	= Woofer; extremely low resonance frequency
22 = 2 to 2 1/2	square		T	= Tweeter; high frequency range
30 = 3	round		Sq	= Squawker; for mid-range frequencies
33 = 3	square		HP	= High power-handling capacity
35 = 3 x 5	oval		MFB	= Motional feedback
38 = 3 x 8	oval			
40 = 4	round			
44 = 4	square			
46 = 4 x 6	oval			
50 = 5	octagonal			
57 = 5 x 7	oval			
69 = 6 x 9	oval			
70 = 7	octagonal			
80 = 8	octagonal			

Magnet system

- 10 = Ferroxdure, 102 mm φ
- 40 = Ferroxdure, 60 mm φ
- 60/61/62/63 = Ferroxdure, 72 mm φ
- 65/66/67 = Ferroxdure, 90 mm φ
- 70/71 = Ferroxdure, 30 mm φ
- 80/81/82 = Ferroxdure, 53 mm φ
- 85 = Ferroxdure, 46 mm φ
- 90/91/92 = Sinterpot, Ticonal, 18 mm φ
- 99 = Sinterpot, Ticonal, 10 mm φ
- 100 = Ferroxdure, 130 mm φ

Example: AD0162/T8 = 1 -inch dome, 72 mm φ Ferroxdure magnet, tweeter, 8 Ω.

RESPONSE CURVES

For the medium and low power range a curve of an unmounted loudspeaker, showing the sound pressure as a function of the frequency is given in the data sheets.

For the high power range curves are given of a loudspeaker mounted on an IEC baffle or mounted in an enclosure and, for the squawkers and tweeters, a directional response curve is also given.

TERMS AND DEFINITIONS

"Unmounted": The loudspeaker is placed in a clamping set-up which does not influence its radiation characteristics.

"Mounted in enclosure": The loudspeaker with the gasket outside the enclosure of dimensions specified on the data sheet (flush mounted or front mounted as specified).

"Baffle": The loudspeaker is fitted to a baffle of dimensions specified on the data sheet (flush mounted or front mounted).

"Half free field": The acoustical conditions on the forward side approach those of free space.

"Anechoic room": The acoustical conditions approach those of free space. (IEC Publication 268, Part 5, Section 1).

"Operating power": Is the sine-wave power input to the loudspeaker which corresponds with a sound level of 96 dB with respect to 2×10^{-4} μbar at a microphone distance of 1 m. This sound level is the average level over the rated frequency range of the loudspeaker.



TEST METHODS AND MEASUREMENTS

The atmospheric conditions for measurement are:

Temperature	:	15 to 35 °C
Relative humidity	:	45 to 75 %
Pressure	:	860 to 1060 mbar

1 Impedance

The impedance is the modulus of the lowest value of the electrical impedance in the frequency range above the bass resonance frequency of the loudspeaker as determined by the method specified in para. 3 below.

1.1 Measuring apparatus

- Audio-frequency sine-wave generator with a constant output voltage over the range 0 to 20 000 Hz.
- Linear amplifier with an output impedance not greater than 1/3 of the rated loudspeaker impedance and a power output of approx. 0,1 x the power-handling capacity of the loudspeaker.
- A 1 Ω resistor connected in series with the loudspeaker.
- An electronic voltmeter shunted across the 1 Ω resistor.

1.2 Conditions

- The loudspeaker is unmounted.
- The power input to the loudspeaker will not exceed 0,1 x the power-handling capacity as determined in para. 4 below.

1.3 Measuring result

Rated impedance is stated on the data sheets. The measured impedance will not be lower than 20% of the rated impedance.

2 Voice coil resistance

The voice coil resistance is the (d. c.) resistance of the voice coil.

2.1 Measuring apparatus

Low current d. c. ohmmeter.

2.2 Conditions

The d. c. power input to the loudspeaker does not exceed 0,1 x the power-handling capacity.

2.3 Measuring result

The rated resistance is given on the data sheets, tolerance ± 10%.

3. Resonance frequency

The resonance frequency is that frequency where the modulus of the electrical impedance has its first principal maximum in an ascending scale, the electrical input being such as to have no significant effect on the resonant frequency.

3.1 Measuring apparatus

Same as for "Impedance". See para. 1.

3.2 Conditions

- The loudspeaker is measured unmounted.
- The resonance frequency is determined after applying to the loudspeaker for a duration of 5 s a test signal equal to that required to test the power handling capacity.

3.3 Measuring result

The resonance frequency is that frequency at which the voltmeter indicates the first minimum deflection as the frequency is swept slowly from 0 Hz, the output voltage of the amplifier being such that the voltmeter reads for the resonance frequency:

40 to 60 mV for loudspeakers with a rated impedance less than 20 Ω ;

15 to 25 mV for loudspeakers with a rated impedance between 20 Ω and 100 Ω ;

4 to 6 mV for loudspeakers with a rated impedance greater than 100 Ω .

The rated resonance frequency is stated on the data sheets.

4 Power handling capacity

The power handling capacity is the nominal power which the loudspeaker will satisfactorily handle as checked by an accelerated life test.

4.1 Test apparatus

- Generator supplying test signal in accordance with IEC268, para. 9.3.
- Power amplifier with an output impedance not greater than 1/3 of the rated impedance of the loudspeaker.
- Voltmeter indicating the r. m. s. value of the voltage.

4.2 Conditions

- A test voltage is applied to the loudspeaker for an uninterrupted period of 100 hrs. The r.m.s. value of this voltage corresponds with the specified power handling capacity of the loudspeaker.
- The test voltage has a frequency distribution corresponding with that of the output of a filter as specified in IEC Publication 268, part 5 para. 9.3 when fed from a white noise source.
- If the loudspeaker is designed to operate in a restricted frequency range, the corresponding network (filter) which is connected to the loudspeaker during the test, is specified on the data sheet. The test voltage is measured at the input terminals of the network.
- The method of mounting is as specified on the data sheet.

4.3 Test result

To pass this test the loudspeaker has to function properly at the end of the test period. Deviation from the specified resonance frequency is allowed.

5 **Total non-linear distortion**

This is the ratio between the r.m.s. value of the harmonic content of the sound pressure to the value of the total sound pressure over the frequency range of the loudspeaker.

The difference in dB between fundamentals and harmonic contents, can be converted into a distortion percentage with the aid of following nomogram.

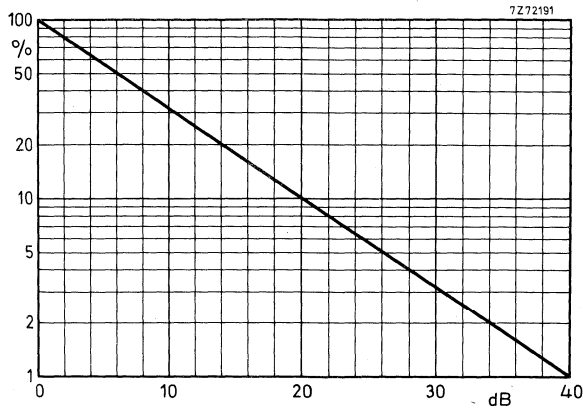

Difference in dB converted into % distortion

5.1 Conditions

- The loudspeaker is mounted as specified on the data sheet.
- The power input to the loudspeaker is the operating power.
- The microphone distance is as specified on the data sheet. (See also definition of "Operating power")

5.2 Measuring result

The distortion curve with its limit of high power loudspeakers is given on the data sheet.

6 Sweep voltage

The sweep voltage test involves the loudspeaker to receive a sinusoidal test signal of specified constant amplitude. The frequency of this signal is swept through the specified frequency range.

6.1 Test apparatus

- Audio-frequency sinus-signal generator with a constant output voltage over the range from 0 to 20 000 Hz.
- Linear amplifier with an output power appropriate to the loudspeaker under test and an output impedance not greater than $1/3$ x the rated loudspeaker impedance. For power see 6.2.
- An electronic voltmeter with high input impedance.

6.2 Conditions

- The loudspeaker is tested unmounted.
- The input voltage is
 - a) for the medium and low power range such that the power input to the loudspeaker is 0,5 x the specified power handling capacity.
 - b) for the High power range as specified on the data sheets.
- If the loudspeaker is designed to operate in a restricted frequency range, the corresponding network (filter) which is connected to the loudspeaker during the test, is specified on the data sheet. The test voltage is measured at the input terminals of the network.

6.3 Test result

To pass this test the loudspeaker has to function properly during the test.

7 Flux density

This is the magnetic flux density measured in the air gap.

7.1 Measuring apparatus

- Differential search coil
- Galvanometer

7.2 Conditions

- The distance between the centres of the two coils is equal to the air gap height minus 1 mm.
- The two coils are put into the air gap symmetrical with respect to the poleplate.

7.3 Measuring result

The minimum flux density as measured on production samples is stated on the data sheet.

8 Frequency response

The frequency response is the graph representing the sound pressure as a function of frequency applying to the loudspeaker a constant sine-wave signal V.

8.1 Measuring apparatus

- | | |
|-------------------------|--------------------------------------|
| - Microphone | Bruel & Kjaer, type 4131, 4145 |
| - Microphone amplifier | Bruel & Kjaer, type 2606, 2607, 2608 |
| - Cathode follower | Bruel & Kjaer, type 2619 |
| - Sine/random generator | Bruel & Kjaer, type 1024 |
| - Level recorder | Bruel & Kjaer, type 2305, 2307 |

The apparatus is set as follows:

- | | |
|----------------------------|----------|
| - Writing speed | 125 mm/s |
| - Paper speed | 3 mm/s |
| - Range potentiometer | 50 dB |
| - Lower limiting frequency | 10 Hz |
| - Rectifier response | r. m. s. |
| - Writing width | 100 mm |
| - Compressor speed | 300 dB/s |

8.2 Conditions

- Sine-wave signal $V = \sqrt{W \cdot Z_r}$
where
- for anechoic room measurements $W = 50 \text{ mW}$, unless otherwise stated on the data sheets.

V = test voltage

Z_r = rated impedance as specified on the data sheet

- Microphone position: in axis of loudspeaker on a distance of 50 cm for anechoic room measurements
- Curve a is measured in a anechoic room; loudspeaker unmounted
- Curve b is measured in a half free field; loudspeaker mounted as specified on the data sheet
- Curve d is measured in a anechoic room; loudspeaker unmounted

8.3 Measuring result

A description of the sensitivity and the frequency response curve(s) are given on the data sheet.

9 **Direction of magnetization**

The magnet is so magnetized that the centre-pole is south for systems with a ring magnet, and north for systems with a slug magnet.

10 **Polarity**

The cone of the loudspeaker will move outwards when a d. c. voltage is applied to the terminals so that the red terminal is positive.

The voltage applied does not exceed the "sweep voltage".



Conversion of catalogue number (for ordering) to type number.

catalogue number	type	catalogue number	type
2403 256 12001	AD0199/Z25	2422 256 30801	AD4692/X4
2403 257 22001	AD2271/T4	30802	X8
22002	T8	30803	X15
23701	AD3370/Y4	30804	X25
23702	Y8	32001	AD2090/T4
23704	Y25	32002	T8
23705	Y150	32003	T15
2404 257 24201	AD4470/Y4	32005	AD2290/T4
24202	Y8	32006	T8
24203	Y15	32007	T15
24204	Y25	34301	AD4090/X8
34301	AD4480/X4	34302	X15
34302	X8	36001	AD5790/M4
34303	X15	36002	X4
46001	AD7062/M4	36003	M8
46002	M8	36004	M15
2404 258 48201	AD8000	36005	X8
2422 256 22201	AD2099/Z25	37001	AD7091/M800
30301	AD3590/X4	37002	X800
30302	X50	37003	M400
30303	X400	37004	M4
30304	X8	37005	X4
30305	X15	37008	X8
30307	X25	37009	M8
30501	AD3890/X4	2422 257 22001	AD2071/T4
30502	X800	22002	T8
30503	X8	23701	AD3070/Y4
30504	X15	23702	Y8
30505	X25	23703	Y15
30506	X70	23704	Y25
30601	AD4691/X4	23801	AD2070/Z4
30602	X8	23802	Z8
30603	X15	23803	Z15
30604	X25	23804	Z25
30612	M4	24203	AD4070/Y15
30613	M800	24204	Y25
30614	M15	24301	AD4085/X4
30615	M8	24302	X8
30616	M25	24311	AD4485/X4
30701	AD4890/X4	24312	X8
30702	X8	30301	AD3880/X4
30703	X15	30302	X8
30704	X25	30303	X15
		30401	AD4681/X4

catalogue number	type	catalogue number	type
2422 257 30402	AD4681/X8	2422 257 37801	AD7080/X4
30403	X15	37802	X8
30404	X25	37803	M4
30409	M4	37804	M8
30411	M8	37805	M15
30413	M25	37906	AD7063/M4
30601	AD4682/X4	37907	M8
30602	X8	37911	AD7060/W4
30603	X15	37912	W8
30604	X25	38211	AD8081/M4
31201	AD1265/W4	38212	M8
31202	W8	38213	X4
31301	AD1065/W4	38214	X8
31302	W8	38405	AD8061/W4
32001	AD0210/Sq4	38406	W8
32002	Sq8	38501	AD8066/W4
33201	AD0140/T4	38502	W8
33202	T8	38601	AD8067/W4
33312	AD0162/T8	38602	W8
33313	T15	38605	MFB
34301	AD4080/X4	39101	AD6980/X4
34302	X8	39102	X8
34303	X15	39103	M4
34304	X25	39104	M8
34311	AD4481/X4	41001	AD1065/M4
35401	AD5060/Sq4	41002	M8
35402	Sq8	41003	M15
35405	AD5061/Sq4	41101	AD1265/M4
35406	Sq8	41102	M8
35501	M4	41103	M15
35502	M8	41201	AD10100/W4
35701	AD5081/X4	41202	W8
35702	X8	41301	AD12100/W4
35703	X15	41302	W8
35704	X25	47001	AD7066/W4
35705	M4	47002	W8
35706	M8	47005	MFB
35707	M15	48101	9710MC
35708	M25	51001	AD12100/M4
36101	AD5780/X4	51002	M8
36102	X8	51003	M15
36103	X15	51101	AD12100/HP4
36104	X25	51102	HP8
36105	M4		
36106	M8		
36107	M15		
36108	M25		

catalogue number	type
4304 078 72500	ADF 500/4500/8
72720	ADF 1600/4
72820	ADF 1600/8
72840	ADF 500/4500/4
72850	ADF 2400/8
72860	ADF 2400/4

=====

1 inch HIGH POWER DOME TWEETER LOUDSPEAKER

APPLICATION

For the reproduction of audio frequencies from 1600 Hz to 22 000 Hz in multi-way high-fidelity loudspeaker systems. Minimum recommended cross-over frequency 1600 Hz with 12 dB/octave slope.

TECHNICAL DATA

	version	
	T4	T8
Rated impedance	4	8 Ω
Voice coil resistance	3,4	6,3 Ω
Rated frequency range	1600 to 20 000 Hz	
Resonance frequency	1200	Hz
Power handling capacity, measured with filter: 12 μF - 0,35 mH	20	W
5 μF - 0,2 mH	40	W
8 μF - 0,5 mH		20 W
3,2 μF - 0,35 mH		40 W
loudspeaker unmounted		
Operating power	4	W
Sweep voltage (500 to 20 000 Hz)	3	4,5 V
Energy in air gap	59	mJ
Flux density	0,9	T
Air-gap height	2,5	mm
Voice coil height	2,4	3,2 mm
Core diameter	25	mm
Magnet material	Ferroxdure	
diameter	61	mm
mass	0,1	kg
Mass of loudspeaker	0,25	kg

The loudspeaker has a polycarbonate dome and a voice coil of aluminium wire.

Connection to the loudspeaker is by means of 3,2 mm (0,12 inch) Fastons or soldering.

Dimensions (mm)

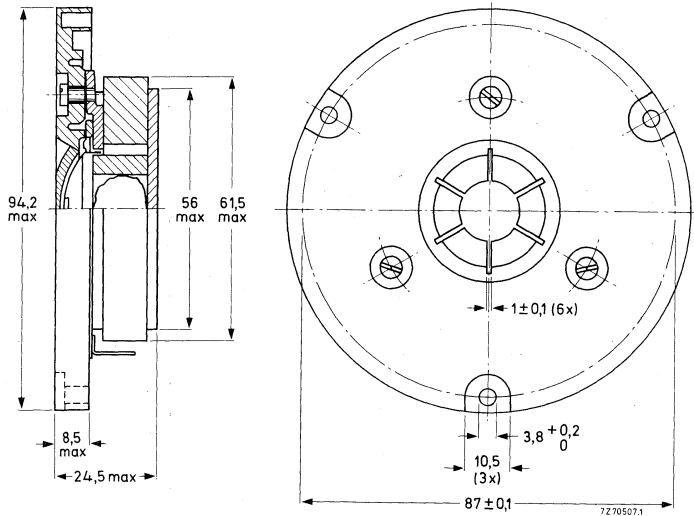

Fig. 1

One tag is indicated by a red mark for in-phase connection

Baffle hole diameter 75 mm.

Face of loudspeaker should lie in line with plane of baffle.

AVAILABLE VERSIONS

AD0140/T4, catalogue number 2422 257 332.1

AD0140/T8, catalogue number 2422 257 332.2

(0 = stamped on loudspeaker magnet,
not to be used for ordering.)

2 = for bulk packing *)

6 = for single unit packing

FREQUENCY RESPONSE CURVES

Curve b: Sound pressure measured in half free field, input at operating power.
Loudspeaker mounted on baffle, dimensions 50 x 50 mm.

Curve c: 2nd and 3rd harmonic distortion, measured at the operating power of 4 W in anechoic room. Loudspeaker unmounted.

*) Minimum packing quantity 9 per unit.

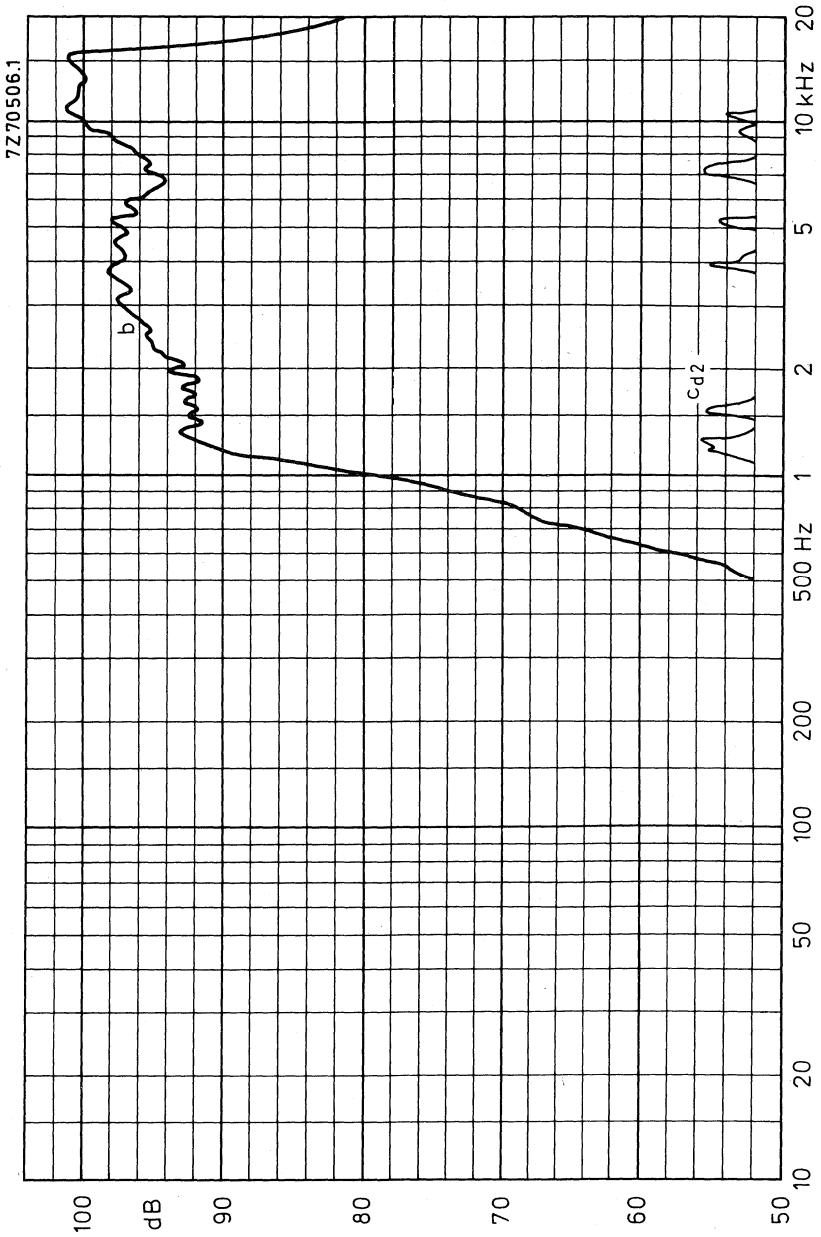

Fig. 2



DEVELOPMENT SAMPLE DATA

This information is derived from development samples made available for evaluation. It does not form part of our data handbook system and does not necessarily imply that the device will go into production

AD0162/T.

1 inch HIGH POWER DOME TWEETER LOUDSPEAKERS

APPLICATION

For use in direct and indirect radiating systems for reproduction of audio frequencies from 2000 Hz to 22 000 Hz with very low distortion in multi-way high fidelity loudspeaker systems in accordance with DIN45500. Minimum recommended cross-over frequency 1600 Hz. The loudspeaker has a very high sensitivity.

TECHNICAL DATA

	version		
	T8	T15	
Rated impedance	8	15	Ω
Voice coil resistance	6,3	12,5	Ω
Rated frequency range	2000 to 22 000		Hz
Resonance frequency	1000		Hz
Power handling capacities a/b (see Fig. 1)			
at 2000 Hz C = 8 μF L = 0,5 mH	20/4		W
C = 3,3 μF L = 1 mH		20/4	W
at 4000 Hz C = 3,2 μF L = 0,35 mH	50/6		W
C = 1,5 μF L = 0,8 mH		50/6	W
Operating power		2	W
Sweep voltage	4,5	5,5	V
frequency range : 500 - 20 000 Hz			
high pass filter : 8 μF - 0,5 mH			
Energy in air gap		75	mJ
Flux density		1,2	T
Air gap height		2,5	mm
Voice coil height	2,4	3,4	mm
Core diameter		25	mm
Magnet material	Ferroxdure		
diameter		72	mm
mass		0,24	kg
Mass of loudspeaker		0,5	kg

The loudspeaker has a polycarbonate dome and a diffusor integrated in the cover.

Connection to the loudspeaker by means of 2,8 mm (0,11 inch) Fastons or soldering.

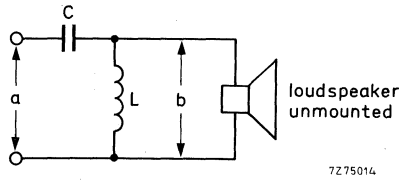

Fig. 1. Measuring circuit.
a = system power handling capacity
b = loudspeaker power handling capacity.

Dimensions (mm)

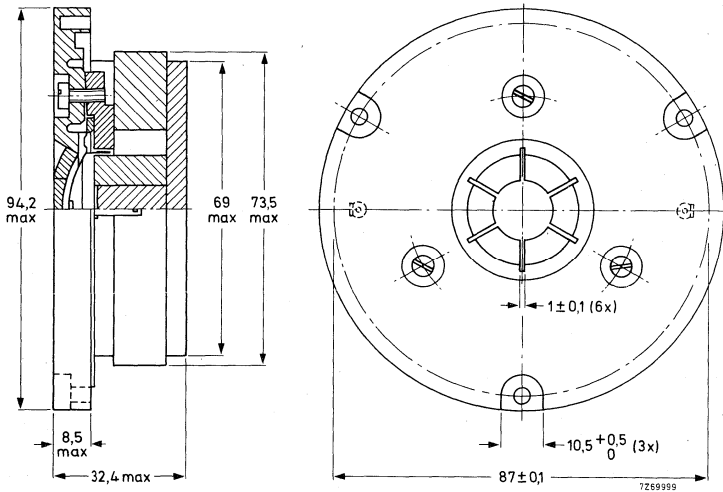

Fig. 2.

One tag is indicated by a red mark for in-phase connection.
Face of loudspeaker should not lie behind plane of baffle.

AVAILABLE VERSIONS

AD0162/T8, catalogue number 2422 257 333.2
AD0162/T15, catalogue number 2422 257 333.3

- (1 = stamped on loudspeaker magnet, not to be used for ordering)
- 3 = for bulk packing *)
- 7 = for single unit packing

*) Minimum packing quantity 9 per unit.

FREQUENCY RESPONSE CURVES (see Fig. 3)

Curve b: Sound pressure measured in anechoic room, loudspeaker unmounted.

Above 1000 Hz, over the width of one octave, the sound pressure may be a maximum of 2 dB lower than indicated.

Curve c: 2nd and 3rd harmonic distortion, measured at the operating power of 2 W in anechoic room, loudspeaker unmounted.



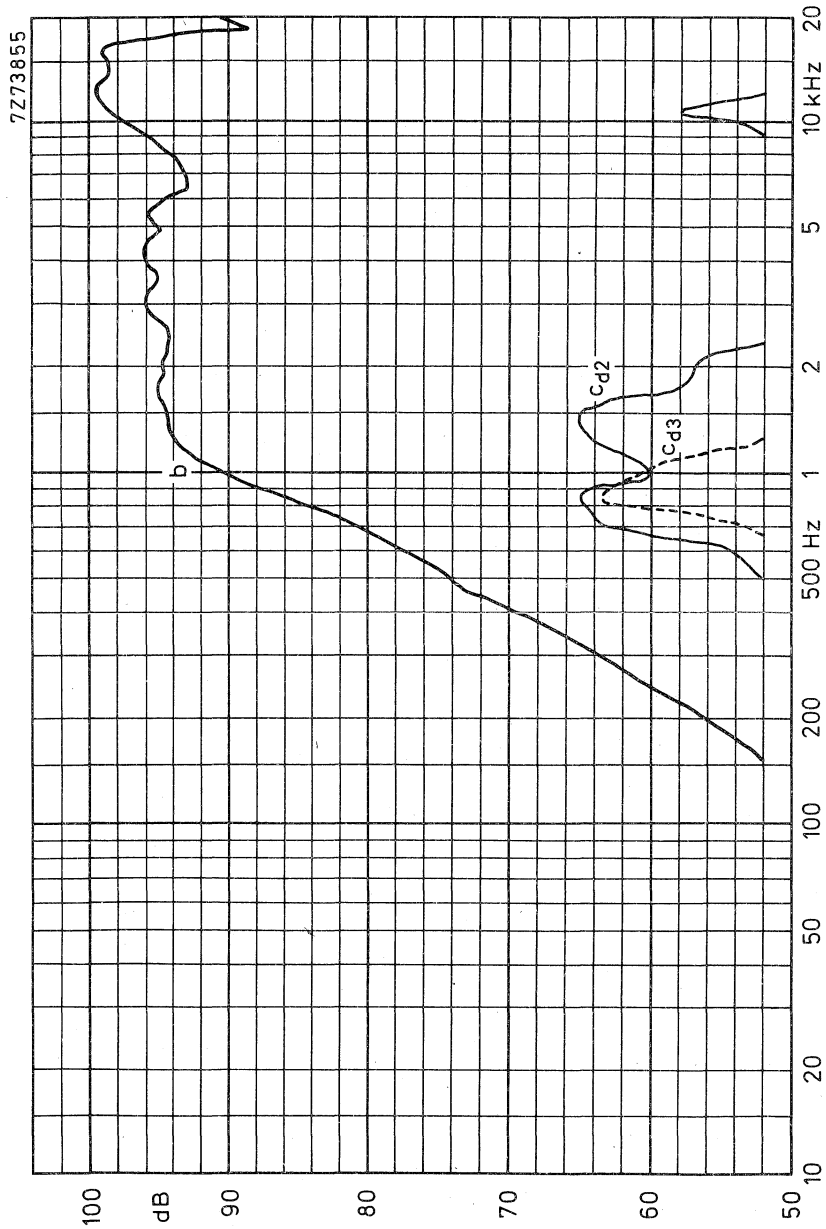

Fig. 3.

1/4 inch ROUND LOW POWER LOUDSPEAKER

APPLICATION

The absence of magnetic stray field due to ticonal sinterpot magnet system, makes this loudspeaker suitable for use in portables, intercoms and dictation equipment where very small dimensions are required.

TECHNICAL DATA

	<u>version Z25</u>	
Rated impedance	25	Ω
Voice coil resistance	19,8	Ω
Resonance frequency	700	Hz
Power handling capacity measured without filter loudspeaker unmounted	0,2	W
Sweep voltage	1,6	V
Energy in airgap	5,3	mJ
Flux density	0,5	T
Airgap height	2,5	mm
Voice coil height	2,3	mm
Core diameter	10	mm
Magnet material	Ticonal	
diameter	10	mm
weight	0,006	kg
Weight of loudspeaker	0,017	kg

The loudspeaker has a paper cone and surround.

Dimensions(mm)

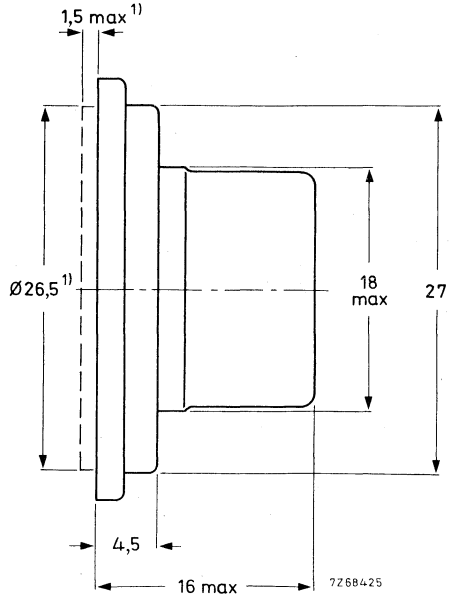
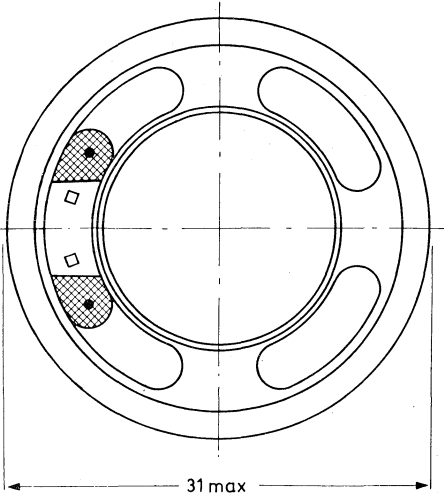

Fig. 1

¹⁾ Baffle hole and clearance depth required for cone movement at the specified power handling capacity.

One tag is indicated by a red mark for in-phase connection.

AVAILABLE VERSION

AD0199/Z25, catalogue number 2403 256 120.1

- (0 = stamped on loudspeaker magnet, not to be used for ordering)
- 2 = for bulk packing
- 6 = for single unit packing

FREQUENCY RESPONSE CURVE

Fig. 2 Sound pressure measured in anechoic room, loudspeaker unmounted.
Between 2000 Hz and 3000 Hz the measured response curve may not deviate.
Input power 50 mW.

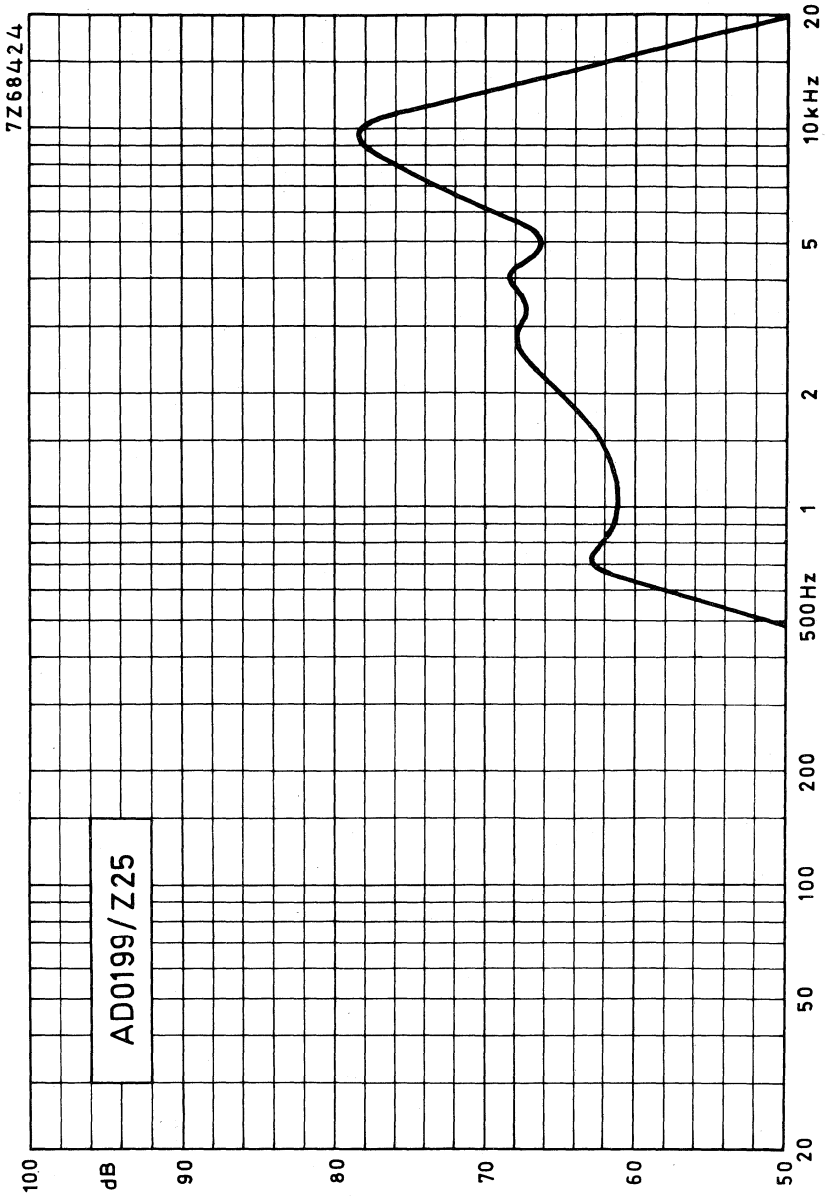

Fig.2



2 inch HIGH POWER DOME SQUAWKER LOUDSPEAKER

APPLICATION

For the reproduction of audio frequencies from 500 to 5000 Hz with very low distortion in multi-way high-fidelity loudspeaker systems according to DIN45500. The loudspeaker has an excellent spherical radiation pattern.

TECHNICAL DATA

	version	
	Sq4	Sq8
Rated impedance	4	8 Ω
Voice coil resistance	3,4	6,6 Ω
Resonance frequency	370	Hz
Rated frequency range	550 to 5000	Hz
Power handling capacity, measured with filter 36 μF - 1,2 mH 18 μF - 2,4 mH loudspeaker unmounted	60	W
Power handling capacity of speaker only	20	W
Operating power	5	W
Sweep voltage (100 to 10 000 Hz, filter 36 μF - 1,2 mH 18 μF - 2,4 mH)	4,5	V 6,3 V
Energy in air gap	0	mJ
Flux density	0,8	T
Air-gap height	5	mm
Voice coil height	3,3	3,6 mm
Core diameter	50	mm
Magnet material	Ferroxdure	
diameter	102	mm
mass	0,42	kg
Mass of loudspeaker	1	kg

The loudspeaker has a paper dome, textile rim and a sealed pot; no acoustic isolation required.

Connection to the loudspeaker is by means of 5,1 mm (0,2 inch) Fastons or soldering.

Dimensions (mm)

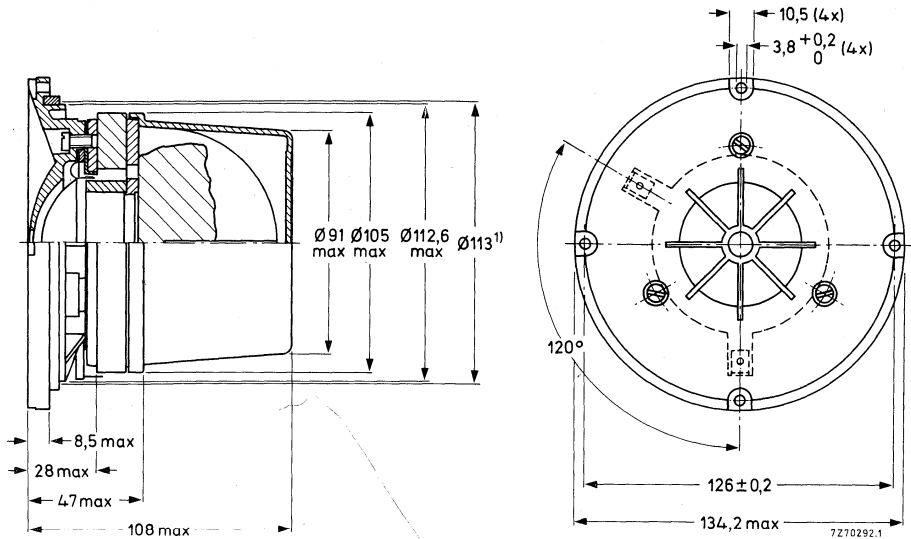

Fig. 1

¹⁾ Baffle hole diameter 110 mm

One tag is indicated by a red mark for in-phase connection

AVAILABLE VERSIONS

AD0210/Sq4, catalogue number 2422 257 320.1

AD0210/Sq8, catalogue number 2422 257 320.2

(0 = stamped on loudspeaker magnet,
not to be used for ordering)

2 = for bulk packing

6 = for single unit packing

FREQUENCY RESPONSE CURVES

See Fig. 2 Input power 50 mW

Curve b: Sound pressure measured in anechoic room, loudspeaker mounted on DIN baffle at operating power.

Curve c: 2nd and 3rd harmonic distortion, measured at the operating power of 5 W in anechoic room. Loudspeaker front mounted on DIN baffle.

2 inch HIGH POWER DOME SQUAWKER
LOUDSPEAKER

AD0210/Sq.

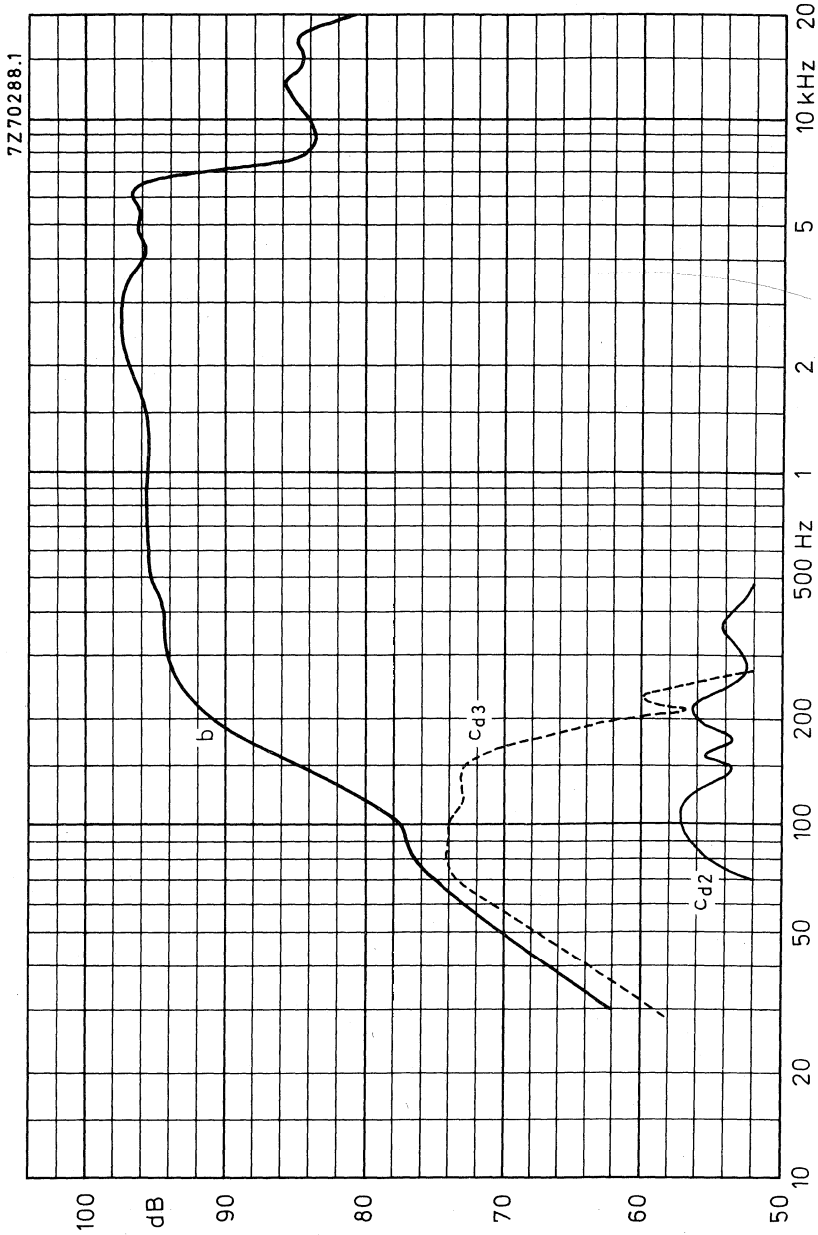

Fig. 2



2½ inch ROUND LOW POWER LOUDSPEAKER

APPLICATION

For portable receivers and intercoms

TECHNICAL DATA

	version				
	Z4	Z8	Z15	Z25	
Rated impedance	4	8	15	25	Ω
Voice coil resistance	3,5	7,1	13,7	22,8	Ω
Resonance frequency	360	360	360	360	Hz
Power handling capacity, measured without filter loudspeaker unmounted	0,5	0,5	0,5	0,5	W
Sweep voltage	1	1,4	1,9	2,5	V
Energy in airgap	12,7	12,7	12,7	12,7	mJ
Flux density	0,74	0,74	0,74	0,74	T
Airgap height	2,5	2,5	2,5	2,5	mm
Voice coil height	2,7	2,2	3	3,6	mm
Core diameter	10	10	10	10	mm
Magnet material	Fxd	Fxd	Fxd	Fxd	
diameter	31	31	31	31	mm
weight	0,02	0,02	0,02	0,02	kg
Weight of loudspeaker	0,064	0,064	0,064	0,064	kg

The loudspeaker has a paper cone and surround.

Dimensions (mm)

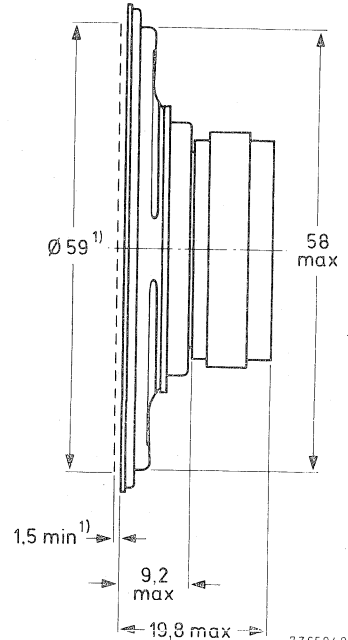
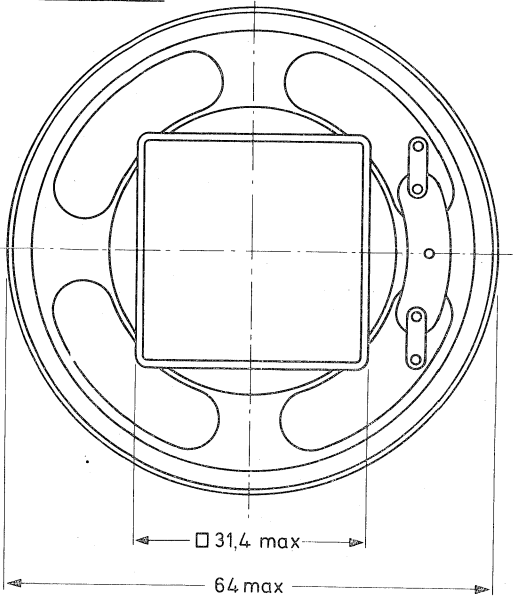

Fig. 1

7265949

¹⁾ Baffle hole and clearance depth required for cone movement at the specified power handling capacity.

One tag is indicated by a red mark for in-phase connection.

AVAILABLE VERSIONS

AD2070/Z4, catalogue number 2422 257 238.1

AD2070/Z8, catalogue number 2422 257 238.2

AD2070/Z15, catalogue number 2422 257 238.3

AD2070/Z25, catalogue number 2422 257 238.4

(0 = stamped on loudspeaker magnet, not to be used for ordering)

2 = for bulk packing *)

6 = for single unit packing

FREQUENCY RESPONSE CURVE

Fig. 2 Sound pressure measured in anechoic room, loudspeaker unmounted. Above 1000 Hz the sensitivity may be, over the width of one octave, maximum 2 dB lower than indicated. Input power 50 mW.

*) Minimum packing quantity 5 per unit

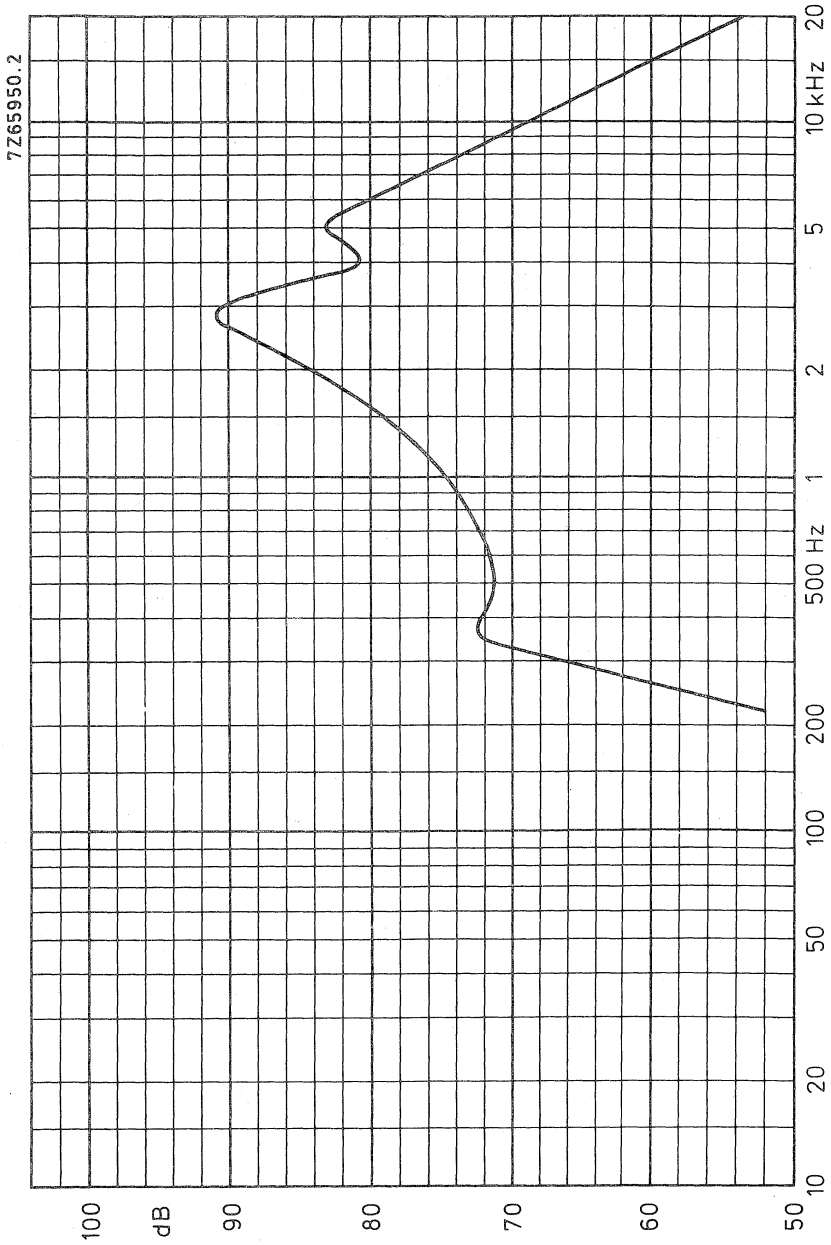

Fig.2



2¼ inch HIGH POWER TWEETER LOUDSPEAKER

APPLICATION

Application in acoustic enclosures.
Rated frequency range 1500 Hz to 10 000 Hz.

TECHNICAL DATA

	version		
	T4	T8	
Rated impedance	4	8	Ω
Voice coil resistance	3,5	7,1	Ω
Resonance frequency	1000	1000	Hz
Power handling capacity, measured with a series capacitor of 5 μF and a signal acc. DIN45573	10	10	W *)
Sweep voltage	1,4	2	V
Energy in airgap	12,7	12,7	mJ
Flux density	740	740	mT
Airgap height	2,5	2,5	mm
Voice coil height	2,7	2,2	mm
Core diameter	10	10	mm
Magnet material	Fxd	Fxd	
diameter	31	31	mm ∅
weight	0,02	0,02	kg
Weight of loudspeaker	0,07	0,07	kg

The loudspeaker has a paper cone and surround.

*) With a cross-over frequency at 2400 Hz.

AD2071/T.
AD2271/T.

2¼ inch HIGH POWER TWEETER
LOUDSPEAKER

Dimensions (mm)

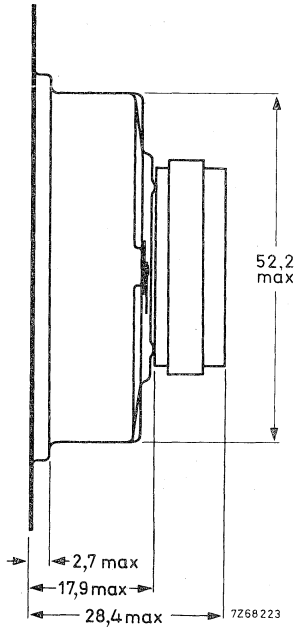
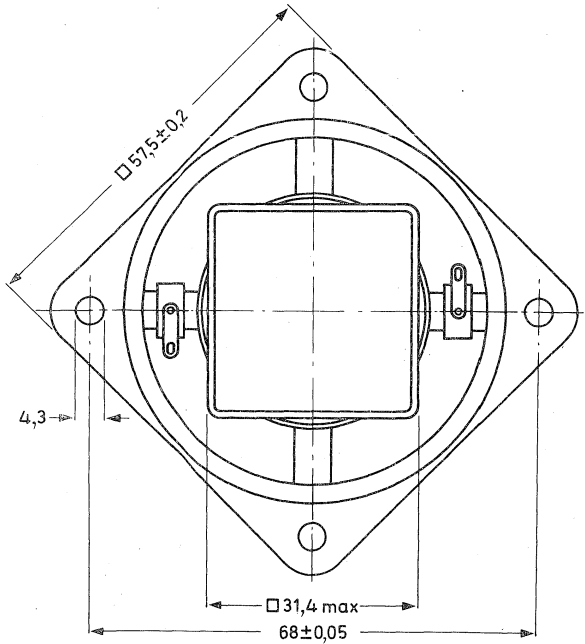
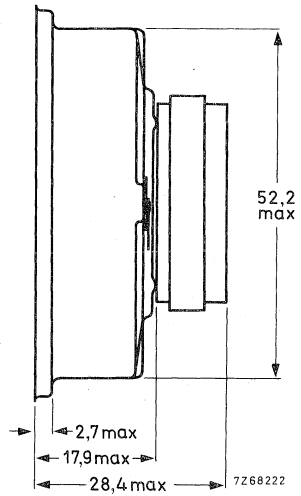
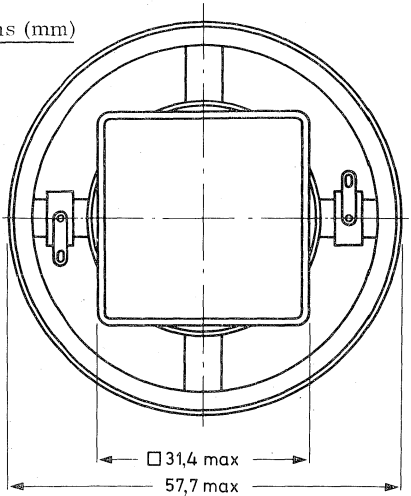

Fig. 1

Baffle hole diameter: 52 mm (front mounting)

One tag is indicated by a red mark for in-phase connection.

AVAILABLE VERSIONS

Round flange version

AD 2071/T4, catalogue number 2422 257 220.1

AD 2071/T8, catalogue number 2422 257 220.2

Square flange version

AD 2271/T4, catalogue number 2403 257 220.1

AD 2271/T8, catalogue number 2403 257 220.2

(0 = stamped on loudspeaker magnet
not to be used for ordering).

2 for bulk packing *)
6 for single unit packing.

FREQUENCY RESPONSE CURVE

Fig. 2. Input power 50 mW.

Sound pressure measured in anechoic room, loudspeaker unmounted. The characteristic may be, over the width of one octave, maximum 2 dB lower than indicated.

*) Minimum packing quantity 25 per unit.

AD2071/T.
AD2271/T.

2¼ inch HIGH POWER TWEETER
LOUDSPEAKER

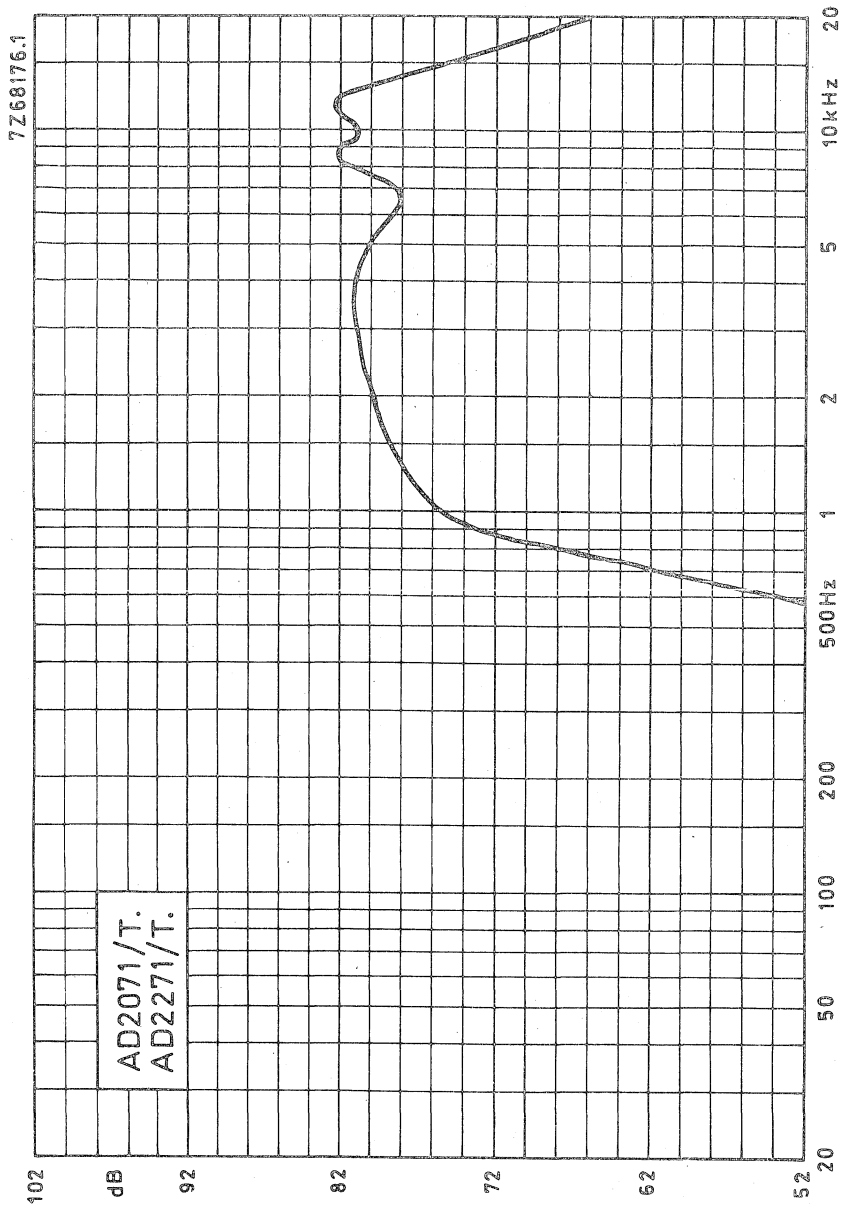

Fig. 2

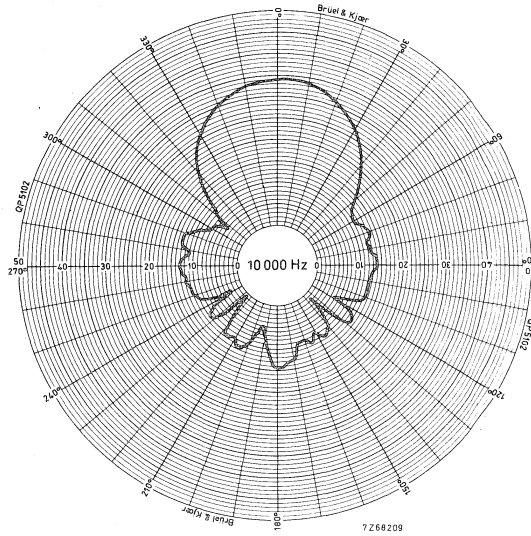

Fig. 3 Directional curve.

Sound pressure measured in anechoic room at 10 000 Hz, loudspeaker unmounted.

2 inch HIGH POWER TWEETER LOUDSPEAKER

APPLICATION

For reproduction of audio frequencies up to 20 kHz with very low distortion in multi-way high fidelity loudspeaker systems in accordance with DIN 45500. Due to absence of stray field from the tweeter magnet system, this loudspeaker may be used in television sets.

TECHNICAL DATA

	version			
	T4	T8	T15	
Rated impedance	4	8	15	Ω
Voice coil resistance	3,3	6,6	13	Ω
Resonance frequency	1300			Hz
Rated frequency range	3000 to 20 000			Hz
Power handling capacity, loudspeaker in series with capacitor of	12	2 5	2,7	W μF
Operating power	4,7			W
Sweep voltage (600 to 20 000 Hz) loudspeaker in series with capacitor of	2,8 12	4 5	5,5 2,7	V μF
Energy in air gap	39			mJ
Flux density	0,85			T
Air-gap height	3			mm
Voice coil height	2,8			mm
Core diameter	18			mm
Magnet material	Ticonal			
diameter	18			mm
mass	0,027			kg
Mass of loudspeaker	0,1			kg

The loudspeaker has a paper cone and surround.

AD2090/T.
AD2290/T.

2 inch HIGH POWER TWEETER
LOUDSPEAKER

Dimensions (mm)

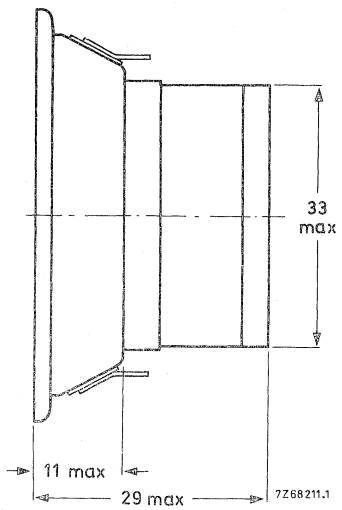
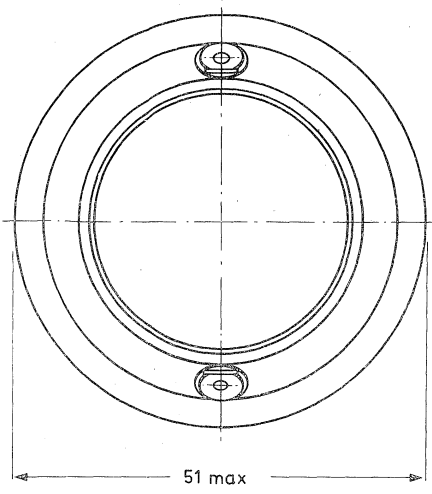

Fig. 1a

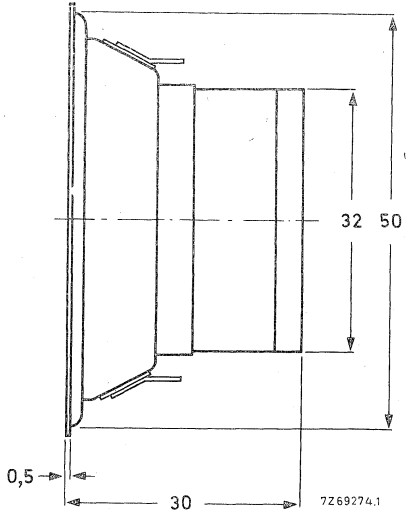
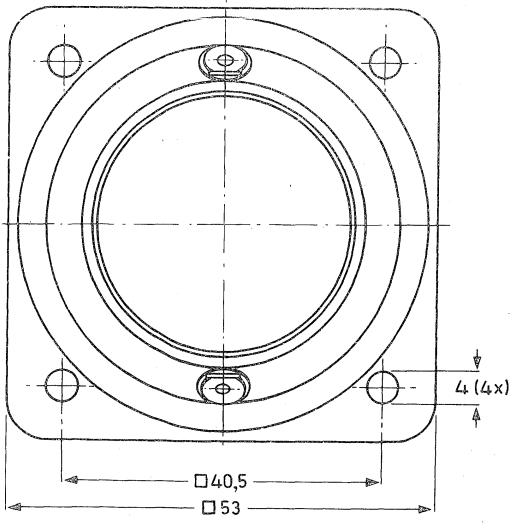

Fig. 1b

Baffle hole diameter 44 mm

One tag is indicated by a red mark for in-phase connection.

AVAILABLE VERSIONS

- AD2090/T4, catalogue number 2422 256 320.1
AD2090/T8, catalogue number 2422 256 320.2
AD2090/T15, catalogue number 2422 256 320.3
AD2290/T4, catalogue number 2422 256 320.5
AD2290/T8, catalogue number 2422 256 320.6
AD2290/T15, catalogue number 2422 256 320.7
- (0 = stamped on loudspeaker magnet
not to be used for ordering).
- 2 for bulk packing *)
6 for single unit packing

FREQUENCY RESPONSE CURVES

Curve a: Sound pressure measured in anechoic room, loudspeaker unmounted. The characteristic may be over the width of one octave, maximum 2 dB lower than indicated. Input power 50 mW.

Curve c: Total non-linear distortion, measured at the operating power in anechoic room (microphone distance 1 m), loudspeaker mounted on baffle.

Curve d: Direction curves at different frequencies, see Fig.3 to 5.

*) Minimum packing quantity 25 per unit.

AD2090/T.
AD2290/T.

2 inch HIGH POWER TWEETER
LOUDSPEAKER

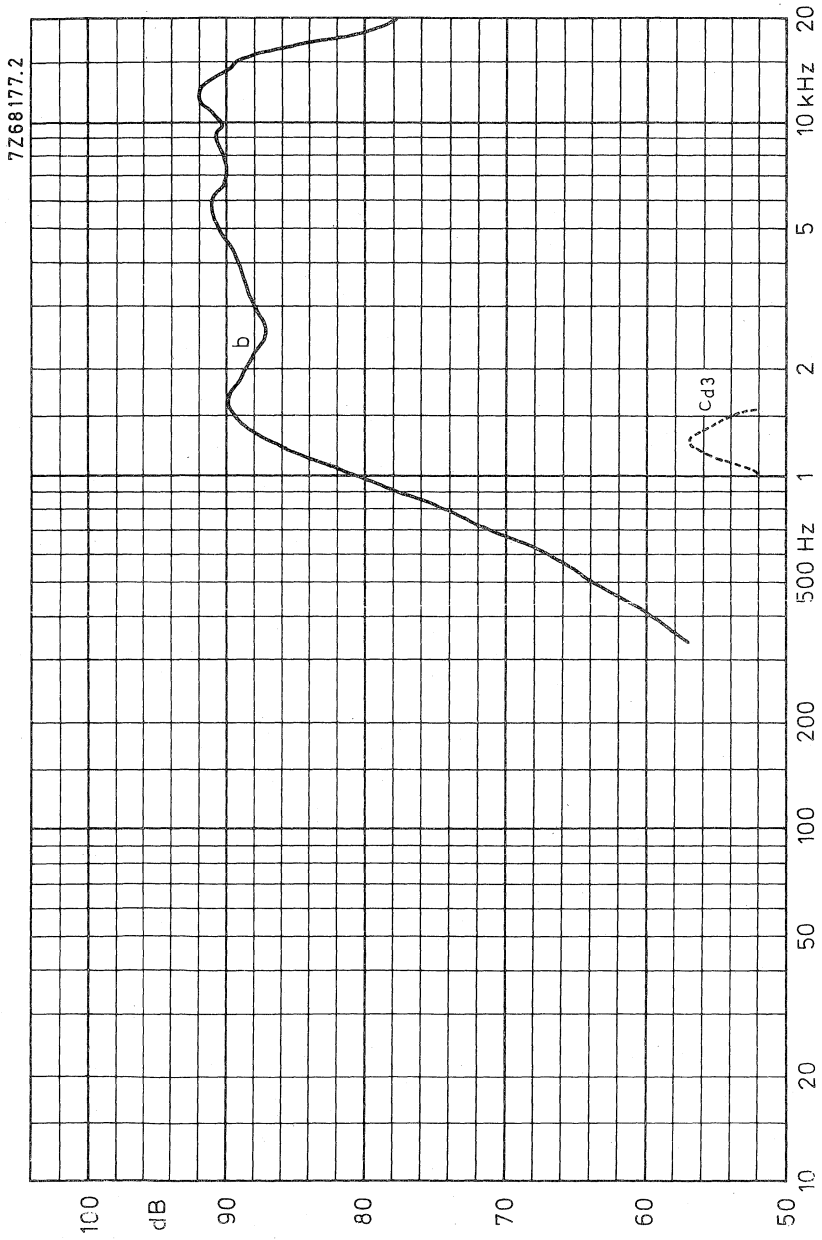

Fig. 2.

Directional curves at different frequencies (AD2090/T8)

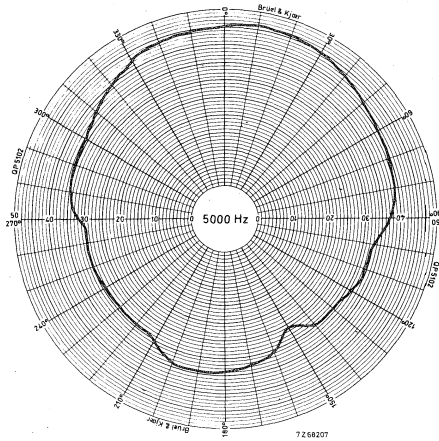

Fig. 3

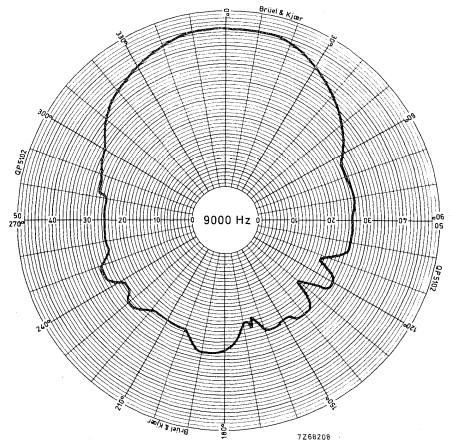

Fig. 4

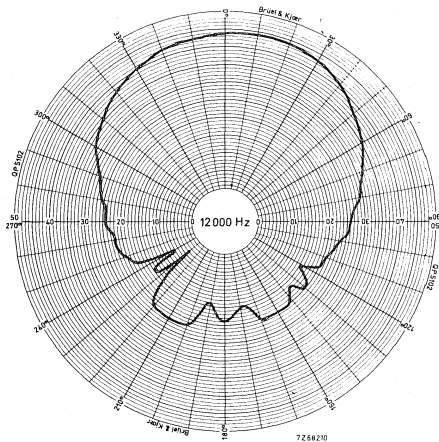

Fig. 5

2 inch ROUND LOW POWER LOUDSPEAKER

APPLICATION

The absence of magnetic stray field due to Ticonal sinterpot magnet system, makes this loudspeaker suitable for use in portables, intercoms and dictation equipment where very small dimensions are required.

TECHNICAL DATA

Rated impedance	25 Ω
Voice coil resistance	19,8 Ω
Resonance frequency	420 Hz
Power handling capacity measured without filter loudspeaker unmounted	0,3 W
Sweep voltage	2,5 V
Energy in air gap	5,3 mJ
Flux density	0,5 T
Air-gap height	2,5 mm
Voice coil height	2,3 mm
Core diameter	10 mm
Magnet material	Ticonal
diameter	10 mm
mass	0,006 kg
Mass of loudspeaker	0,021 kg

The loudspeaker has a paper cone and surround.

Dimensions(mm)

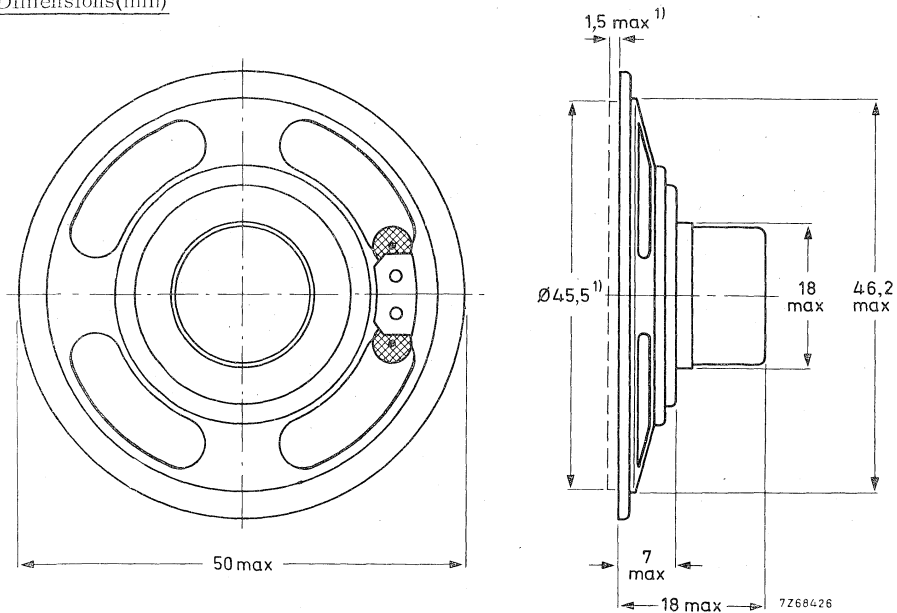

Fig. 1

1) Baffle hole and clearance depth required for cone movement at the specified power handling capacity.

One tag is indicated by a red mark for in-phase connection.

AVAILABLE VERSION

AD2099/Z25, catalogue number 2422 256 222.1

- (0 = stamped on loudspeaker magnet, not to be used for ordering)
- 2 = for bulk packing
- 6 = for single unit packing

FREQUENCY RESPONSE CURVE

Fig. 2 Sound pressure measured in anechoic room, loudspeaker unmounted.
Above 1000 Hz the sensitivity may be, over the width of one octave, maximum 2 dB lower than indicated.
Input power 50 mW.

2 inch ROUND LOW POWER
LOUDSPEAKER

AD2099/Z25

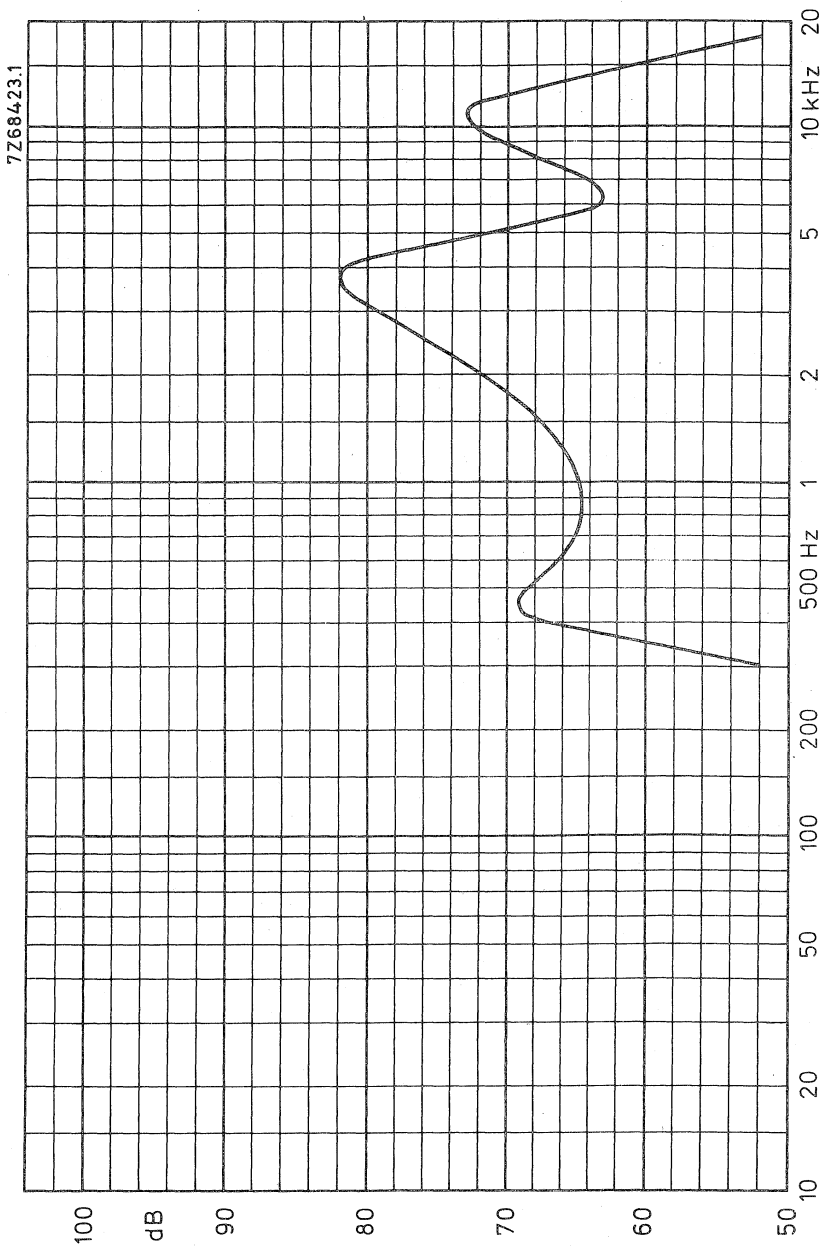

Fig. 2



3 inch LOW POWER LOUDSPEAKER

APPLICATION

For portable receivers and intercoms

TECHNICAL DATA

	version					
	Y4	Y8	Y15	Y25	Y150	
Rated impedance	4	8	15	25	150	Ω
Voice coil resistance	3,5	7,1	13,7	22,8	127	Ω
Resonance frequency	250	250	250	250	250	Hz
Power handling capacity, measured without filter loudspeaker unmounted	1	1	1	1	1	W
Sweep voltage	1,4	2	2,7	3,5	8,7	V
Energy in airgap	12,7	12,7	12,7	12,7	12,7	mJ
Flux density	0,74	0,74	0,74	0,74	0,74	T
Airgap height	2,5	2,5	2,5	2,5	2,5	mm
Voice coil height	2,7	2,2	3	3,6	3,5	mm
Core diameter	10	10	10	10	10	mm
Magnet material	Fxd	Fxd	Fxd	Fxd	Fxd	
diameter	31	31	31	31	31	mm ∅
weight	0,02	0,02	0,02	0,02	0,02	kg
Weight of loudspeaker, round flange	0,069	0,069	0,069	0,069		kg
square flange	0,075	0,075		0,075	0,075	kg

The loudspeaker has a paper cone and surround.

Dimensions (mm)

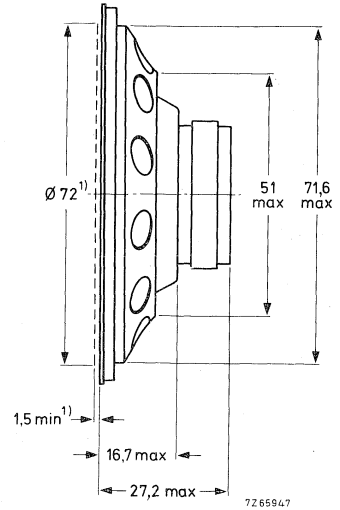
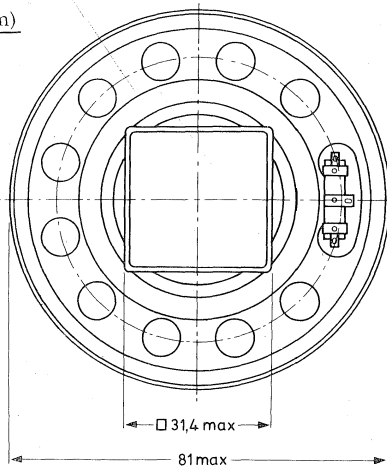

Fig. 1a Round flange version

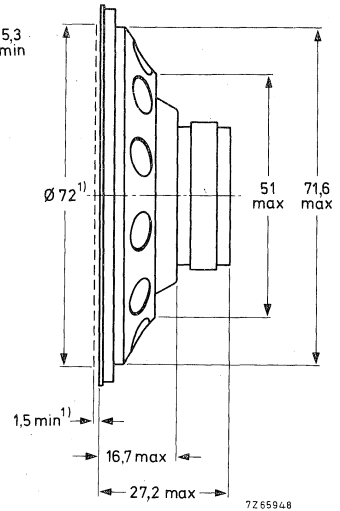
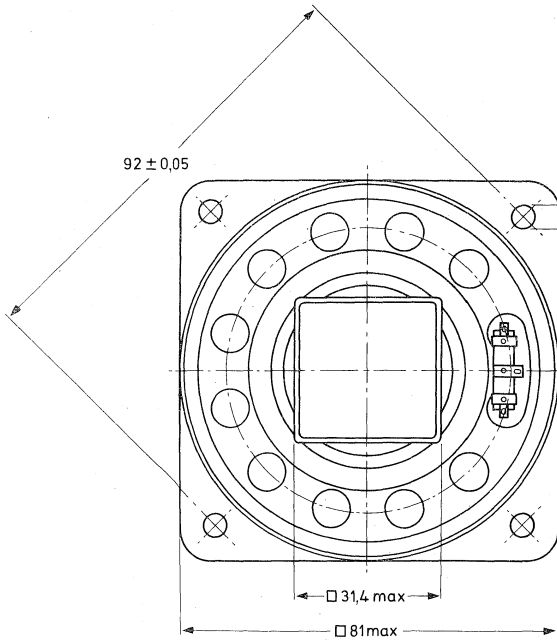

Fig. 1b Square flange version

1) Baffle hole and clearance depth required for cone movement at the specified power handling capacity.
One tag is indicated by a red mark for in-phase connection.

AVAILABLE VERSIONS

Round flange version

- AD3070/Y4, catalogue number 2422 257 237.1
- AD3070/Y8, catalogue number 2422 257 237.2
- AD3070/Y15, catalogue number 2422 257 237.3
- AD3070/Y25, catalogue number 2422 257 237.4

(0 = stamped on loudspeaker magnet,
not to be used for ordering)

Square flange version

- AD3370/Y4, catalogue number 2403 257 237.1
- AD3370/Y8, catalogue number 2403 257 237.2
- AD3370/Y25, catalogue number 2403 257 237.4
- AD3370/Y150, catalogue number 2403 257 237.5

2 = for bulk packing *)

6 = for single unit packing

FREQUENCY RESPONSE CURVE

Fig.2 Sound pressure measured in anechoic room, loudspeaker unmounted.
Above 1000 Hz the sensitivity may be, over the width of one octave, maximum
2 dB lower than indicated.
Input power 50 mW.

*) Minimum packing quantity 5 per unit



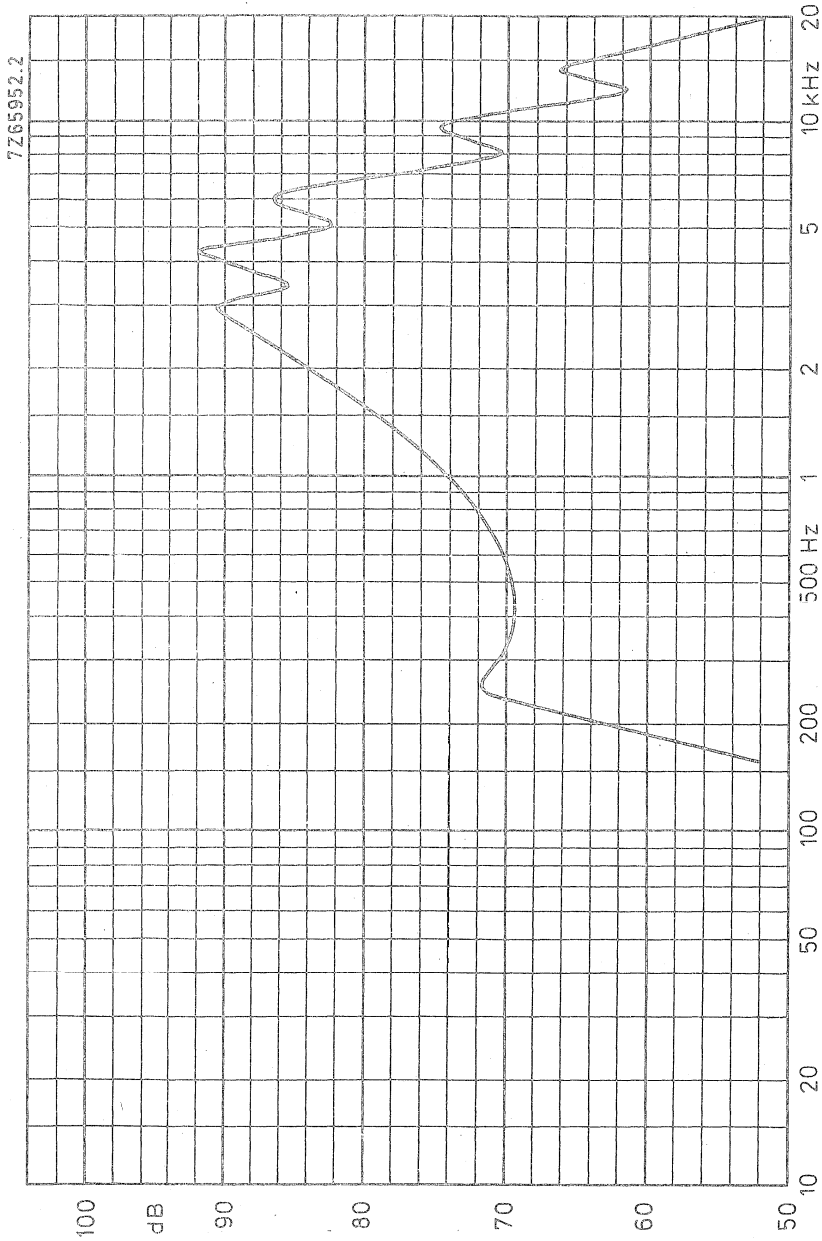

Fig. 2

3x5 inch OVAL MEDIUM POWER LOUDSPEAKER

APPLICATION

For use in portable radios, tape recorders and, due to absence of stray magnetic field, this loudspeaker can also be used in television sets. High sensitivity.

TECHNICAL DATA

	version					
	X4	X8	X15	X25	X50	
Rated impedance	4	8	15	25	50	Ω
Voice coil resistance	3,4	7,2	13,8	22,6	45	Ω
Resonance frequency	180	180	180	180	180	Hz
Power handling capacity, measured without filter loudspeaker unmounted	3	3	3	3	3	W
Sweep voltage	2,4	3,5	4,7	6,1	8,7	V ←
Energy in air gap	39	39	39	39	39	mJ
Flux density	0,8	0,8	0,8	0,8	0,8	T
Air-gap height	3	3	3	3	3	mm
Voice coil height	2	1,8	2,55	2,8	2,9	mm
Core diameter	18	18	18	18	18	mm
Magnet material	Ticonal	Ticonal	Ticonal	Ticonal	Ticonal	
diameter	18	18	18	18	18	mm
mass	0,027	0,027	0,027	0,027	0,027	kg
Mass of loudspeaker	0,13	0,13	0,13	0,13	0,13	kg

The loudspeaker has a paper surround and a foam plastic gasket on the flange.

Dimensions (mm)

Baffle hole

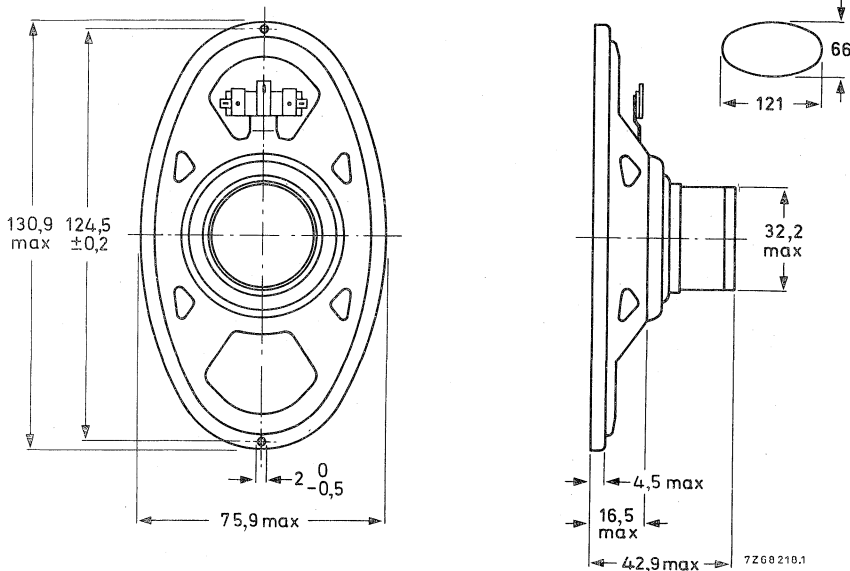

Fig. 1

One tag is indicated by a red mark for in-phase connection

AVAILABLE VERSIONS

- AD 3590/X4, catalogue number 2422 256 303.1
- AD 3590/X8, catalogue number 2422 256 303.4
- AD 3590/X15, catalogue number 2422 256 303.5
- AD 3590/X25, catalogue number 2422 256 303.7
- AD 3590/X50, catalogue number 2422 256 303.2

(0 = stamped on loudspeaker magnet, not to be used for ordering)

- 2 for bulk packing*)
- 6 for single unit packing

FREQUENCY RESPONSE CURVE

Fig. 2. Input power 50 mW
Sound pressure measured in anechoic room, loudspeaker unmounted. Above 100 Hz the sensitivity may be, over the width of one octave, maximum 2 dB lower than indicated.

*) Minimum packing quantity 12 per unit.

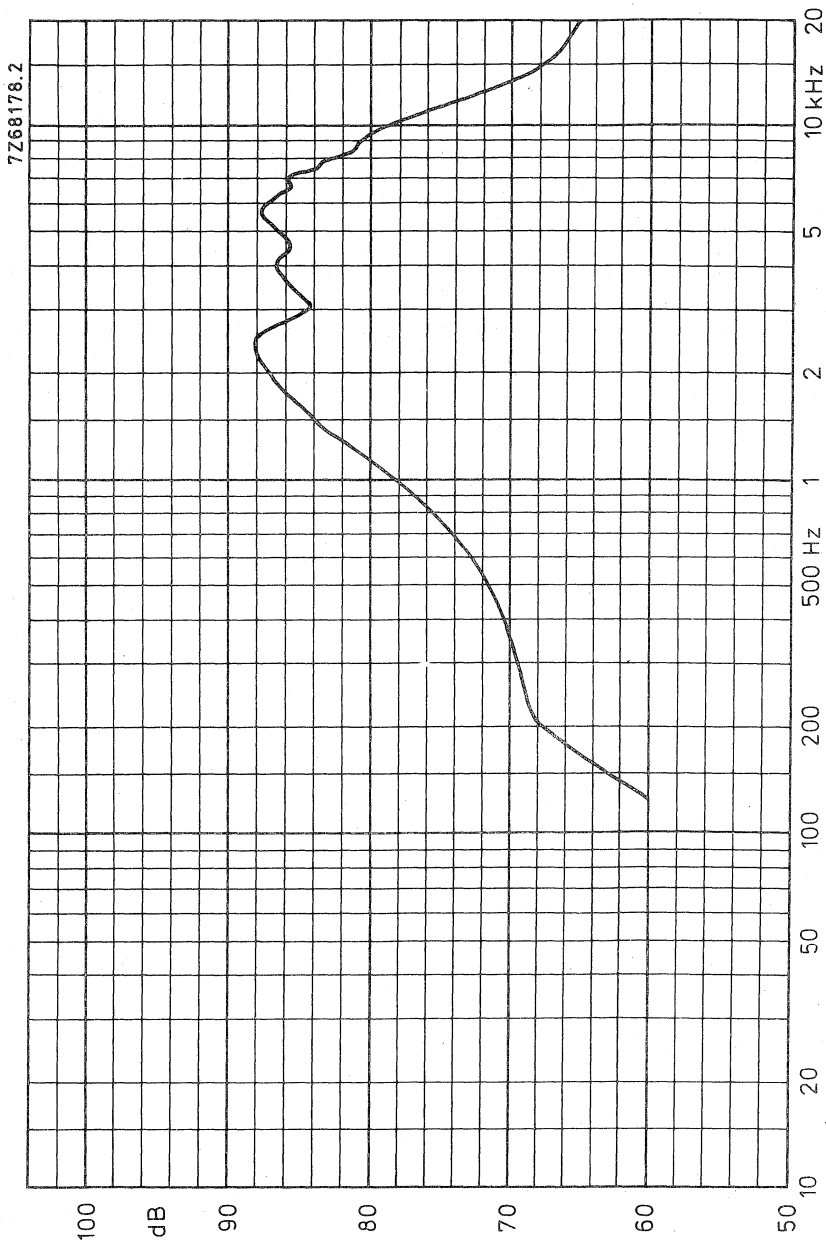

Fig. 2



3x8 inch OVAL MEDIUM POWER LOUDSPEAKER

APPLICATION

For use in portable radios and tape recorders

TECHNICAL DATA

	version			
	X4	X8	X15	
Rated impedance	4	8	15	Ω
Voice coil resistance	3,4	7,1	13,8	Ω
Resonance frequency	120	120	120	Hz
Power handling capacity, measured without filter, loudspeaker unmounted	4	4	4	W
Sweep voltage	2,8	5,5	5,5	V
Energy in airgap	55	55	55	mJ
Flux density	1	1	1	T
Airgap height	3	3	3	mm
Voice coil height	2,4	3,1	2,5	mm
Core diameter	18	18	18	mm
Magnet material	Fxd	Fxd	Fxd	
diameter	53	53	53	mm
weight	0,1	0,1	0,1	kg
Weight of loudspeaker	0,3	0,3	0,3	kg

The loudspeaker has a treated paper surround.

Dimensions (mm)

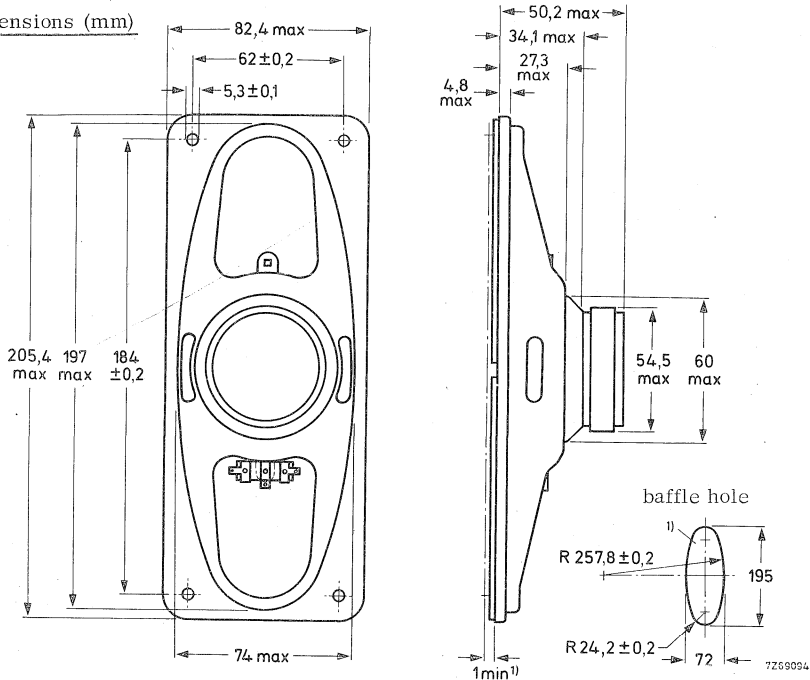

Fig. 1

1) Baffle hole and clearance depth required for cone movement at specified power handling capacity.

One tag is indicated by a red mark for in-phase connection.

AVAILABLE VERSIONS

- AD3880/X4, catalogue number 2422 257 303.1
- AD3880/X8, catalogue number 2422 257 303.2
- AD3880/X15, catalogue number 2422 257 303.3

- (0 = stamped on loudspeaker magnet, not to be used for ordering)
- 2 = for bulk packing *)
- 6 = for single unit packing

FREQUENCY RESPONSE CURVE

See Fig.2. Input power 50 mW

Sound pressure measured in anechoic room, loudspeaker unmounted.
Above 1000 Hz the sound pressure may be, over the width of one octave, maximum 2 dB lower than indicated.

*) minimum packing quantity 6 per unit.

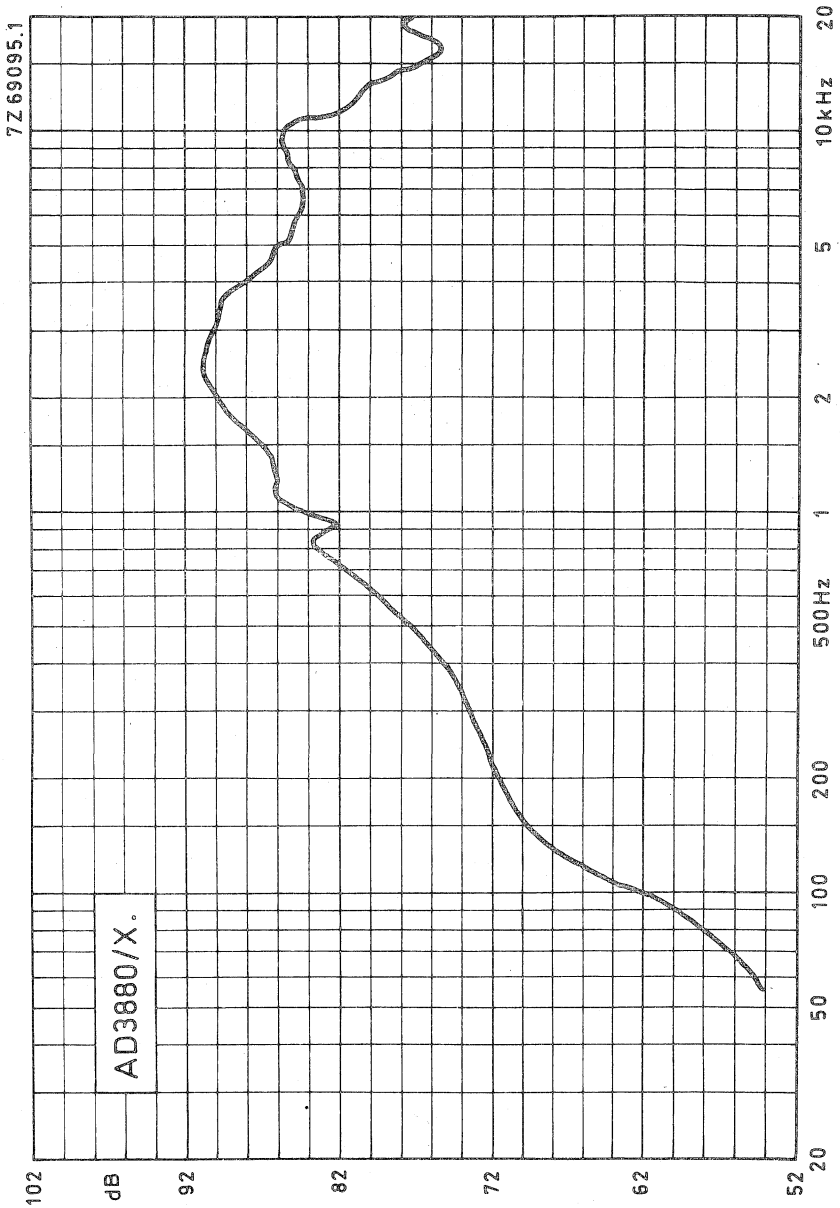

Fig. 2



3×8 inch OVAL MEDIUM POWER LOUDSPEAKER

APPLICATION

For use in portable radios and tape recorders.

The absence of stray field due to ticonal sinterpot magnet system, makes this loudspeaker also suitable for use in television sets.

TECHNICAL DATA

	version					
	X4	X8	X15	X25	X70	X800
Rated impedance	4	8	15	25	70	800 Ω
Voice coil resistance	3,4	7,1	13,5	22,7	58	600 Ω
Resonance frequency	120	120	120	120	120	120 Hz
Power handling capacity, measured without filter, loudspeaker unmounted	4	4	4	4	4	4 W
Sweep voltage	2,8	4	5,5	7,1	11,8	40 V
Energy in airgrap	39	39	39	39	39	39 mJ
Flux density	0,8	0,8	0,8	0,8	0,8	0,8 T
Airgap height	3	3	3	3	3	3 mm
Voice coil height	2,4	2,8	2,5	2,8	4,8	5,1 mm
Core diameter	18	18	18	18	18	18 mm
Magnet material	Ticonal	Ticonal	Ticonal	Ticonal	Ticonal	Ticonal
diameter	18	18	18	18	18	18 mm
weight	0,027	0,027	0,027	0,027	0,027	0,027 kg
Weight of loudspeaker	0,21	0,21	0,21	0,21	0,21	0,21 kg

The loudspeaker has a treated paper surround.

Dimensions (mm)

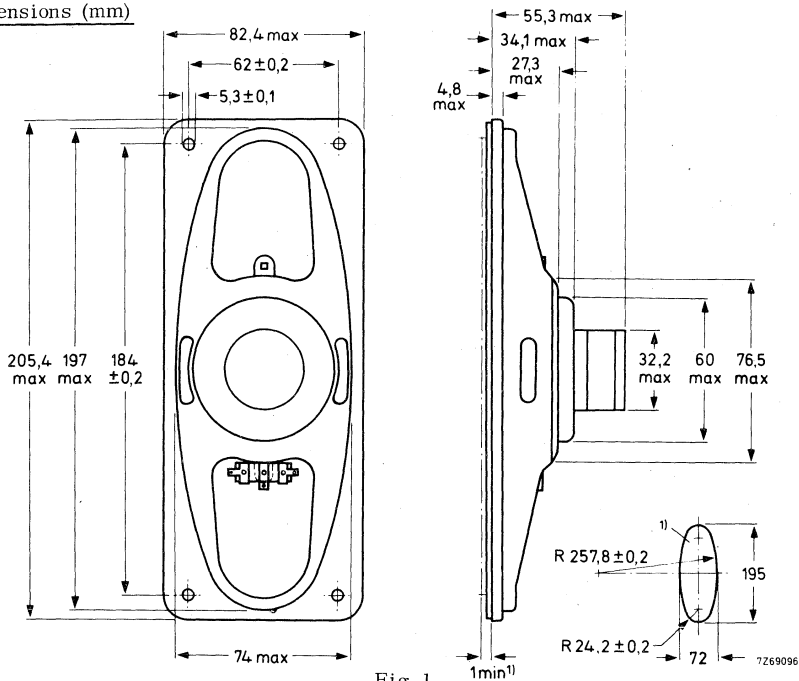

Fig. 1

1) Baffle hole and clearance depth required for cone movement at specified power handling Capacity.

One tag is indicated by a red mark for in-phase connection.

AVAILABLE VERSIONS

- AD3890/X4, catalogue number 2422 256 305.1
- AD3890/X8, catalogue number 2422 256 305.3
- AD3890/X15, catalogue number 2422 256 305.4
- AD3890/X25, catalogue number 2422 256 305.5
- AD3890/X70, catalogue number 2422 256 305.6
- AD3890/X800, catalogue number 2422 256 305.2

(0 = stamped on loudspeaker magnet,
not to be used for ordering)

2 = for bulk packing *)
6 = for single unit packing

FREQUENCY RESPONSE CURVE

See Fig. 2. Input power 50 mW

Sound pressure measured in anechoic room, loudspeaker unmounted.
Above 1000 Hz the sound pressure may be, over the width of one octave,
maximum 2 dB lower than indicated.

*) Minimum packing quantity 6 per unit

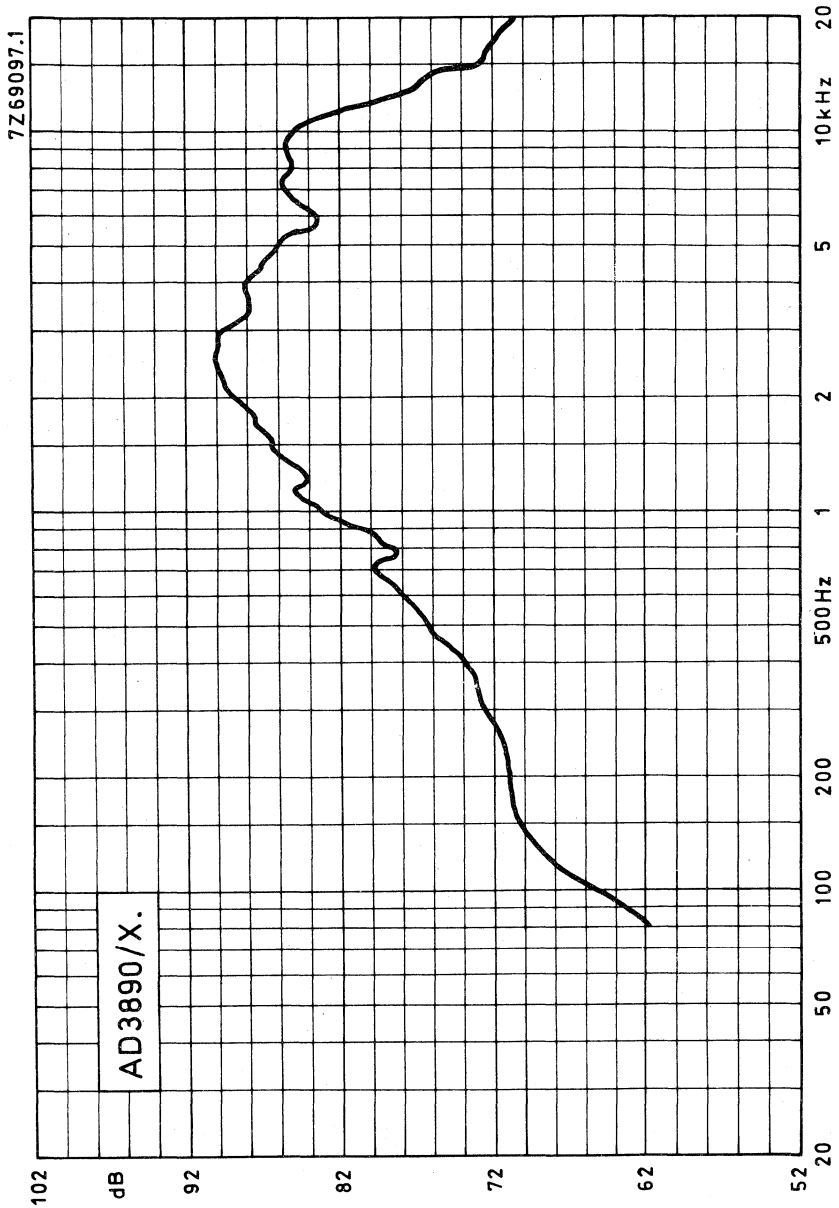

Fig.2



4 inch LOW POWER LOUDSPEAKER

APPLICATION

For portable receivers and intercoms

TECHNICAL DATA

	version				
	Y4	Y8	Y15	Y25	
Rated impedance	4	8	15	25	Ω
Voice coil resistance	3,5	7,1	13,7	22,8	Ω
Resonance frequency	200	200	200	200	Hz
Power handling capacity, measured without filter loudspeaker unmounted	1	1	1	1	W
Sweep voltage	1,4	2	2,7	3,5	V
Energy in airgap	12,7	12,7	12,7	12,7	mJ
Flux density	0,74	0,74	0,74	0,74	T
Airgap height	2,5	2,5	2,5	2,5	mm
Voice coil height	2,7	2,2	3	3,6	mm
Core diameter	10	10	10	10	mm
Magnet material	Fxd	Fxd	Fxd	Fxd	
diameter	31	31	31	31	mm \varnothing
weight	0,02	0,02	0,02	0,02	kg
Weight of loudspeaker, round flange version	0,079	0,079	0,079	0,079	kg
square flange version	0,087	0,087	0,087	0,087	kg

The loudspeaker has a paper cone and surround.

Dimensions (mm)

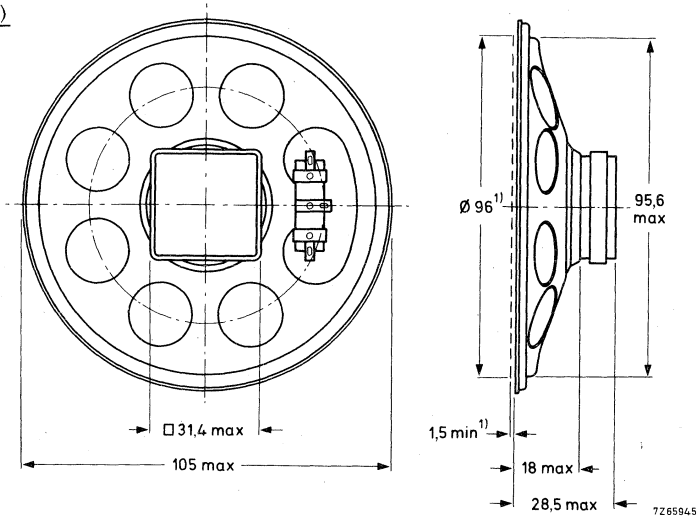

Fig. 1a Round flange version

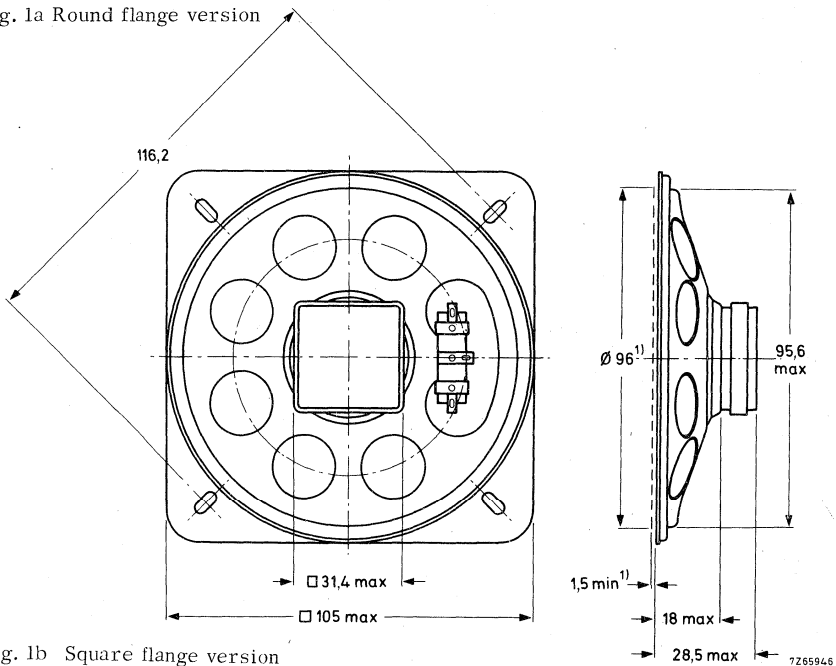

Fig. 1b Square flange version

1) Baffle hole and clearance depth required for cone movement at the specified power handling capacity.
One tag is indicated by a red mark for in-phase connection.

AVAILABLE VERSIONS

Round flange version

- AD4070/Y4 , catalogue number 2422 257 242.1
- AD4070/Y8 , catalogue number 2422 257 242.2
- AD4070/Y15 , catalogue number 2422 257 242.3
- AD4070/Y25 , catalogue number 2422 257 242.4

(0 = stamped on loudspeaker magnet,
not to be used for ordering)

Square flange version

- AD4470/Y4 , catalogue number 2404 257 242.1
- AD4470/Y8 , catalogue number 2404 257 242.2
- AD4470/Y15 , catalogue number 2404 257 242.3
- AD4470/Y25 , catalogue number 2404 257 242.4

— 2 = for bulk packing *)
— 6 = for single unit packing

FREQUENCY RESPONSE CURVE

Fig.2 Sound pressure measured in anechoic room, loudspeaker unmounted.
Above 1000 Hz, the sound pressure may be, over the width of one octave,
maximum 2 dB lower than indicated.
Input power 50 mW.

*) Minimum packing quantity 5 per unit

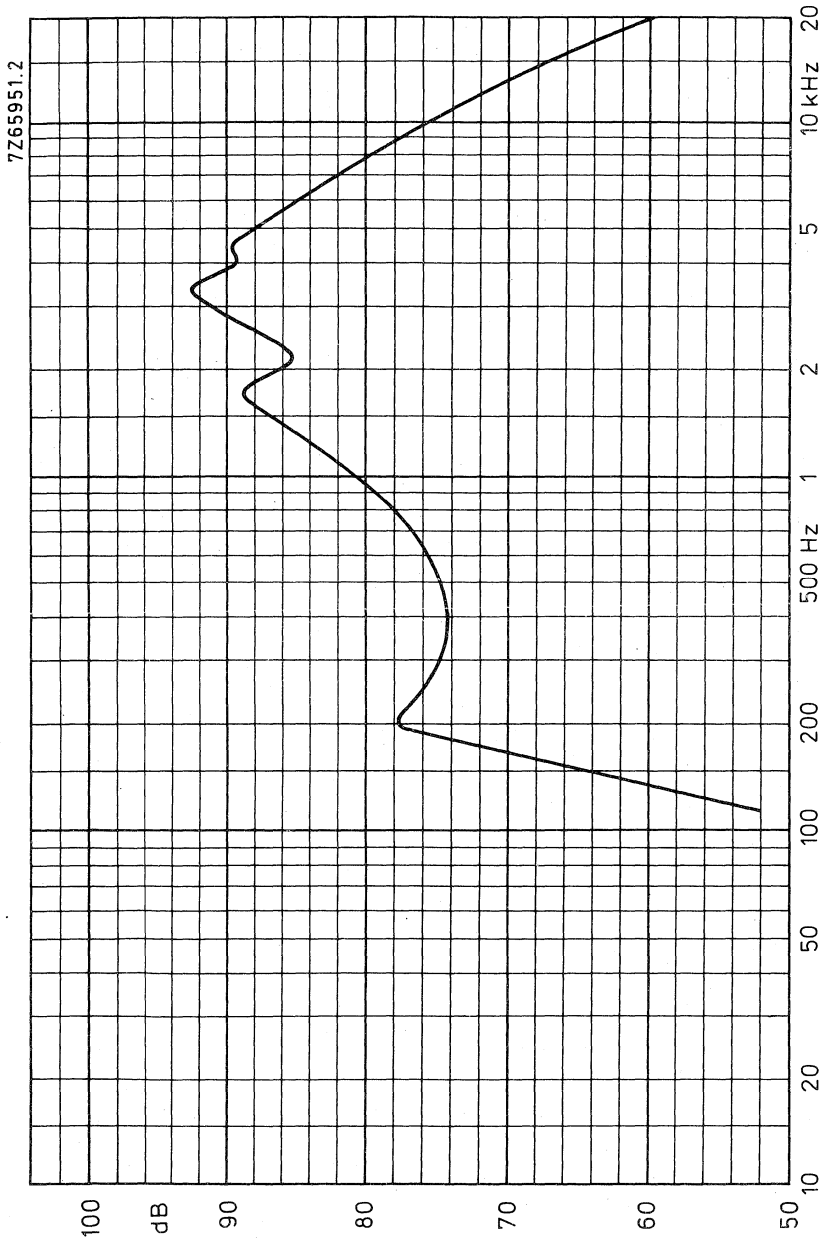

Fig. 2

4 inch MEDIUM POWER LOUDSPEAKER

APPLICATION

For portable receivers, small tape recorders and intercoms.

TECHNICAL DATA

	version				
	X4	X8	X15	X25	
Rated impedance	4	8	15	25	Ω
Voice coil resistance	3, 4	7, 1	13, 8	22, 6	Ω
Resonance frequency	165	165	165	165	Hz
Power handling capacity, measured without filter loudspeaker unmounted	3	3	3	3	W
Sweep voltage	2, 45	3, 5	4, 75	6, 1	V
Energy in airgap	55	55	55	55	mJ
Flux density	1	1	1	1	T
Airgap height	3	3	3	3	mm
Voice coil height	2, 4	3, 1	2, 55	2, 8	mm
Core diameter	18	18	18	18	mm
Magnet material	Fxd	Fxd	Fxd	Fxd	
diameter	53	53	53	53	mm
weight	0, 1	0, 1	0, 1	0, 1	kg
Weight of loudspeaker	0, 25	0, 25	0, 25	0, 25	kg

The loudspeaker has a paper cone and surround.

AD4080/X.
AD4480/X.

4 inch MEDIUM POWER LOUDSPEAKER

Dimensions (mm)

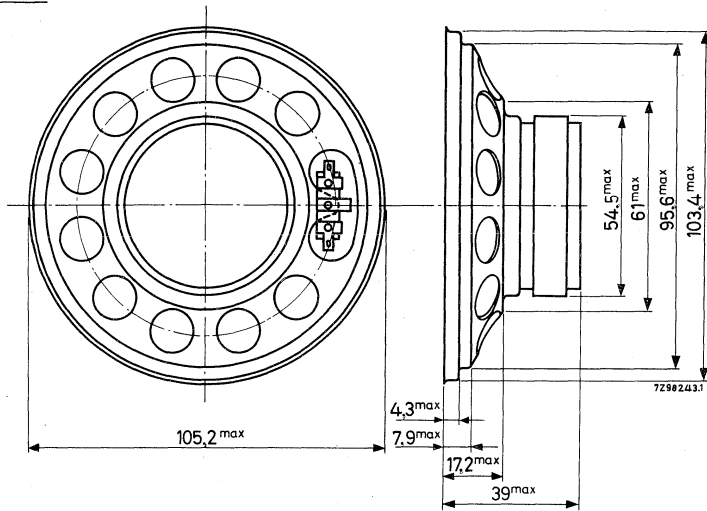

Fig. 1a Round flange version

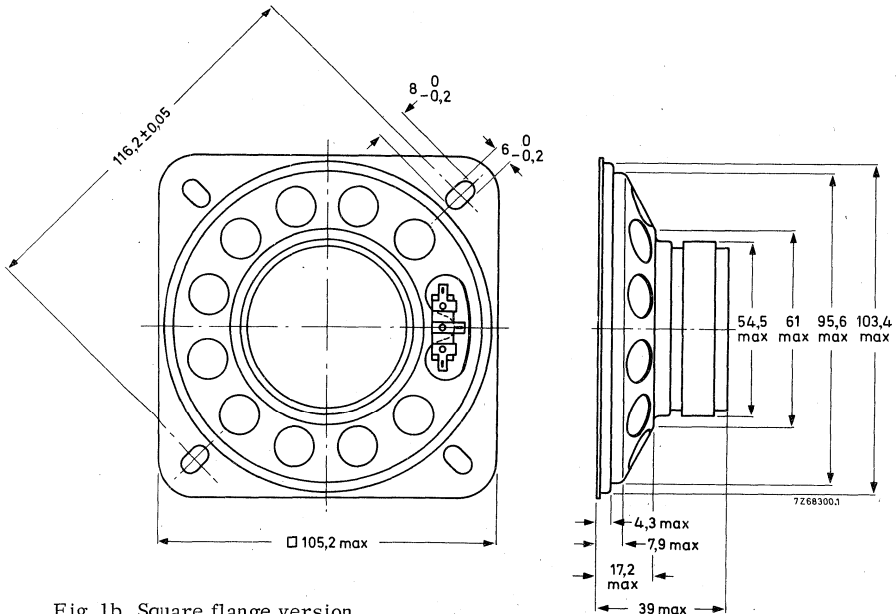

Fig. 1b Square flange version

Baffle hole diameter 96 mm.

One tag is indicated by a red mark for in-phase connection.

AVAILABLE VERSIONS

Round flange version:

AD4080/X4 , catalogue number 2422 257 343.1

AD4080/X8 , catalogue number 2422 257 343.2

AD4080/X15, catalogue number 2422 257 343.3

AD4080/X25, catalogue number 2422 257 343.4

Square flange version:

AD4480/X4 , catalogue number 2404 257 343.1

AD4480/X8 , catalogue number 2404 257 343.2

AD4480/X15, catalogue number 2404 257 343.3

(0 = stamped on loudspeaker magnet
not to be used for ordering)

2 = for bulk packing *)
6 = for single unit packing

FREQUENCY RESPONSE CURVE

Fig. 2 Input power 50 mW
Sound pressure measured in anechoic room, loudspeaker unmounted.
Above 1000 Hz, the sound pressure may be, over the width of one octave,
maximum 2 dB lower than indicated.

*) Minimum packing quantity 9 per unit.

AD4080/X.
AD4480/X.

4 inch MEDIUM POWER LOUDSPEAKER

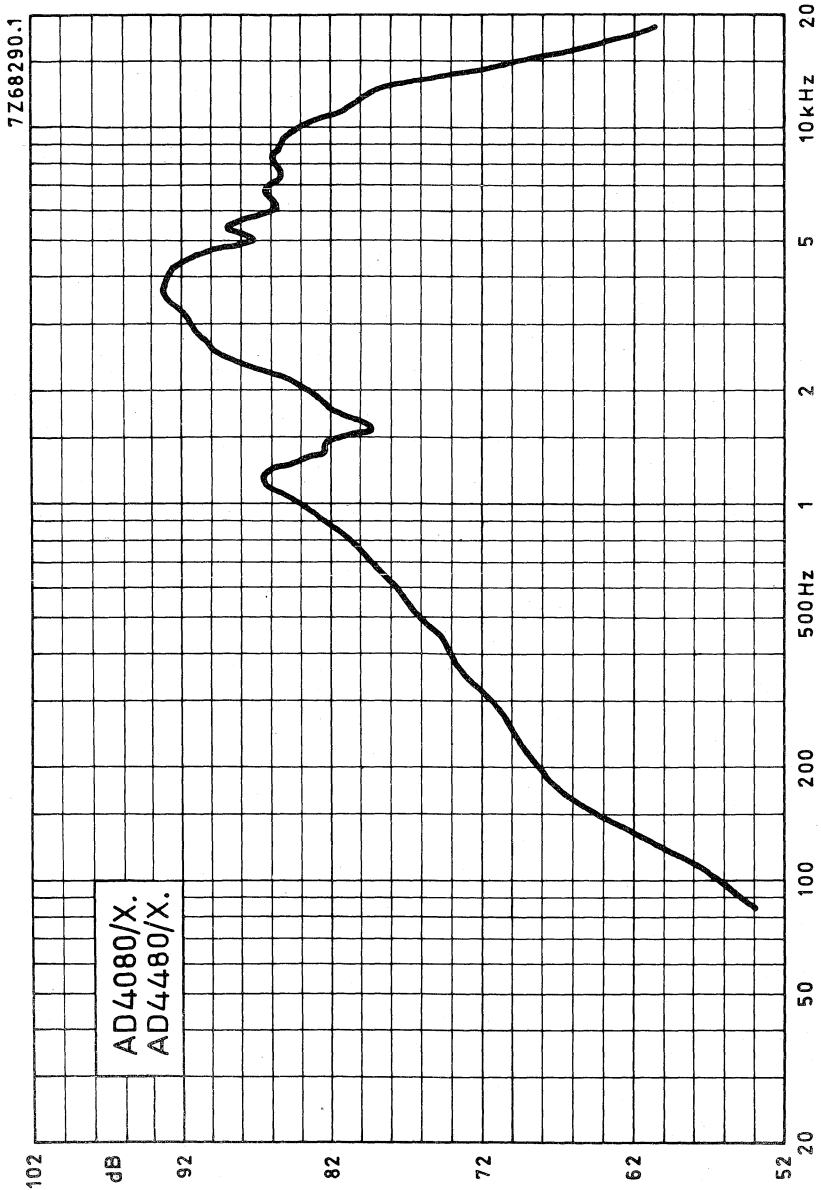

Fig. 2

4 inch MEDIUM POWER LOUDSPEAKERS

APPLICATION

For audio equipment in general. Frequency response up to 12 kHz, high sensitivity in bass region.

TECHNICAL DATA

	version		
	X4	X8	
Rated impedance	4	8	Ω
Voice coil resistance	3,4	7,1	Ω
Rated frequency range	80 to 14 000		Hz
Resonance frequency	150		Hz
Power handling capacity, measured without filter, loudspeaker unmounted	3		W
Operating power (sound level 90 dB, 1 m)	0,7		W
Sweep voltage (75 to 20 000 Hz)	2,5	3,5	V
Energy in air gap	38		mJ
Flux density	1,1		T
Air-gap height	2,5		mm
Voice coil height	3,5	4,1	mm
Core diameter	14		mm
Magnet material	Ferroxdure		
diameter	46		mm
mass	0,053		kg
Mass of loudspeaker	0,16		kg

The loudspeaker has a paper rim. Connections to the loudspeaker can be made by means of Fastons or by soldering.

AD4085/X.
AD4485/X.

4 inch MEDIUM POWER
LOUDSPEAKERS

Dimensions (mm)

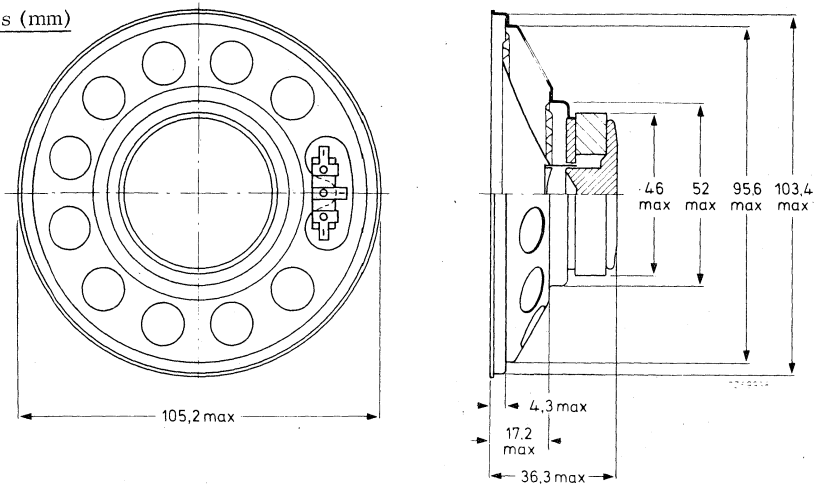

Fig. 1a. Round flange type AD4085/X.

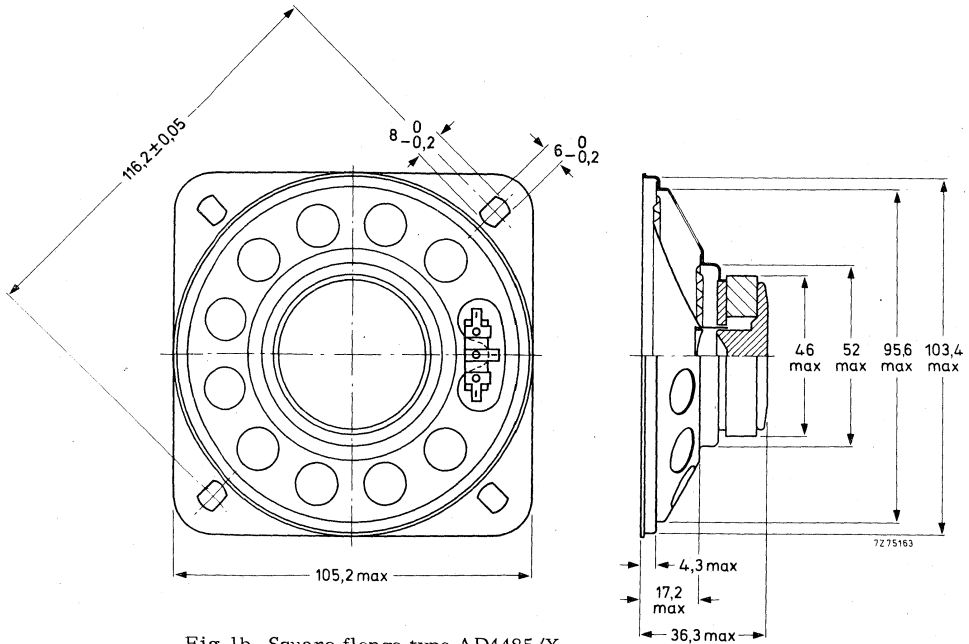

Fig. 1b. Square flange type AD4485/X.

Baffle hole diameter 96 mm.

One tag is indicated by a red mark for in-phase connection.

AVAILABLE VERSIONS

Round flange type

AD4085/X4, catalogue number 2422 257 243.1
AD4085/X8, catalogue number 2422 257 243.2

(0 = stamped on loudspeaker magnet,
not to be used for ordering)

2 = for bulk packing*)
6 = for single unit packing

Square flange type

AD4485/X4, catalogue number 2422 257 243.1
AD4485/X8, catalogue number 2422 257 243.2

(1 = stamped on loudspeaker magnet,
not to be used for ordering)

3 = for bulk packing*)
7 = for single unit packing

FREQUENCY RESPONSE CURVES (see Fig. 2)

Curve b: Sound pressure measured in anechoic room, loudspeaker mounted on baffle according to IEC268-5, par. 4.4.

Curve c: 2nd and 3rd harmonic distortion measured at the operating power of 0,6 W in anechoic room. Loudspeaker front mounted on IEC baffle.

*) Minimum packing quantity 9 per unit.

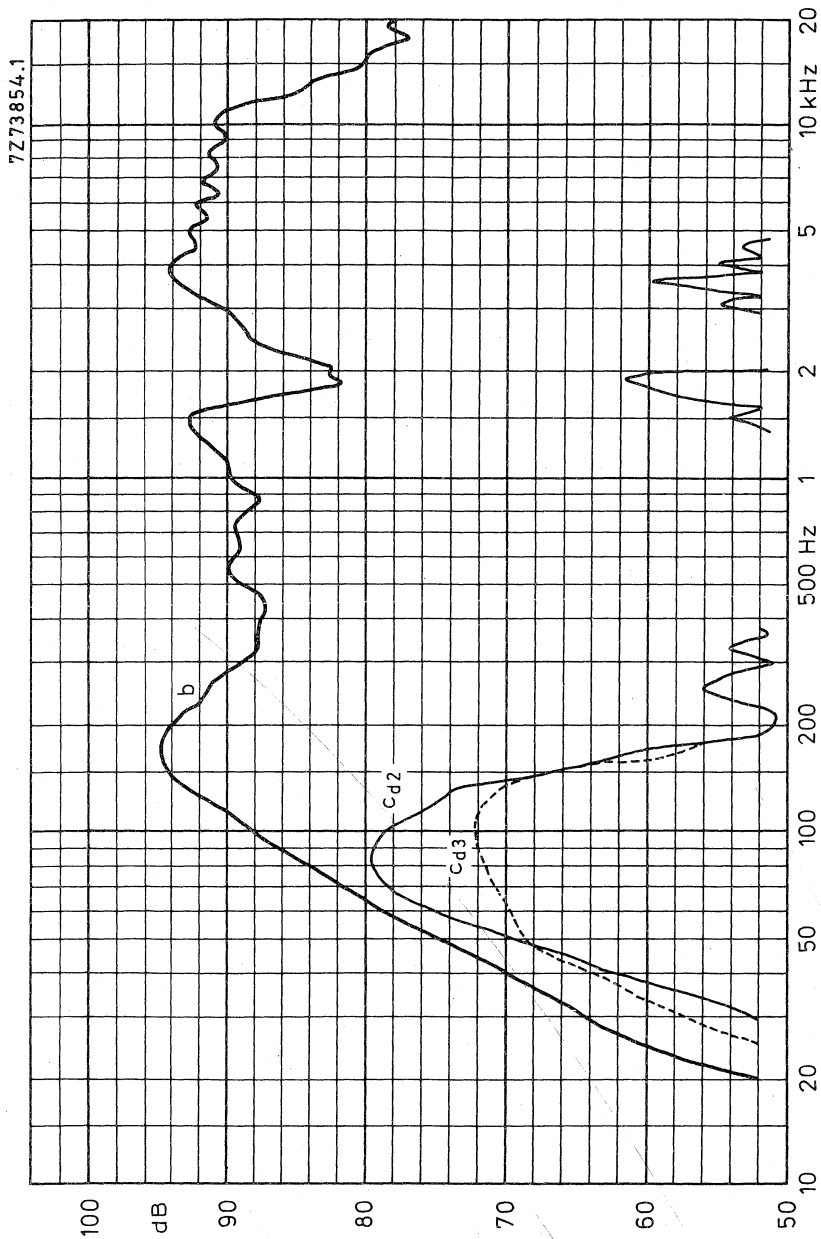

Fig. 2

4 inch LOW POWER LOUDSPEAKER

APPLICATION

For portable receivers.

TECHNICAL DATA

	version		
	X8	X15	
Rated impedance	8	15	Ω
Voice coil resistance	7,2	13,8	Ω
Resonance frequency	190	190	Hz
Power handling capacity, measured without filter loudspeaker unmounted	2	2	W
Sweep voltage	2,8	3,9	V
Energy in airgap	39	39	mJ
Flux density	0,8	0,8	T
Airgap height	3	3	mm
Voice coil height	1,8	2,55	mm
Core diameter	18	18	mm
Magnet material	Ticonal	Ticonal	
diameter	18	18	mm
weight	0,027	0,027	kg
Weight of loudspeaker	0,125	0,125	kg

The loudspeaker has a paper cone and surround.

Dimensions (mm)

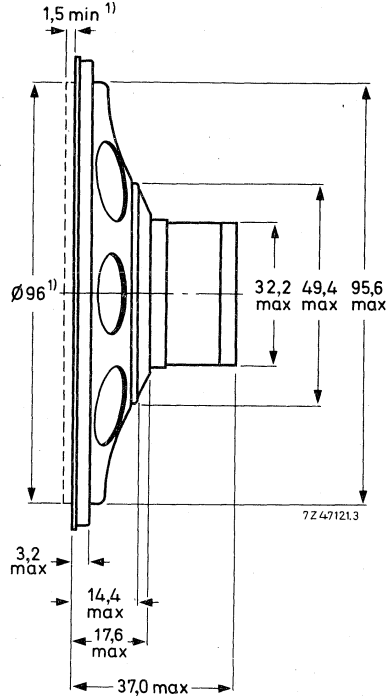
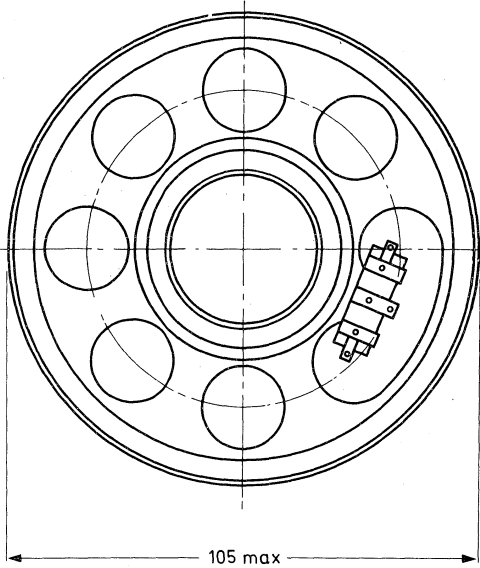

Fig. 1

1) Baffle hole and clearance depth required for cone movement at the specified power handling capacity.

One tag is indicated by a red mark for in-phase connection.

AVAILABLE VERSIONS

AD4090/X8 , catalogue number 2422 256 343.1

AD4090/X15 , catalogue number 2422 256 343.2

(0 = stamped on loudspeaker magnet
not to be used for ordering)

2 = for bulk packing *)

6 = for single unit packing

FREQUENCY RESPONSE CURVE

Fig. 2 Input power 50 mW
Sound pressure measured in anechoic room, loudspeaker unmounted.
Above 1000 Hz the sound pressure may be, over the width of one octave,
maximum 2 dB lower than indicated.

*) Minimum packing quantity 9 per unit.

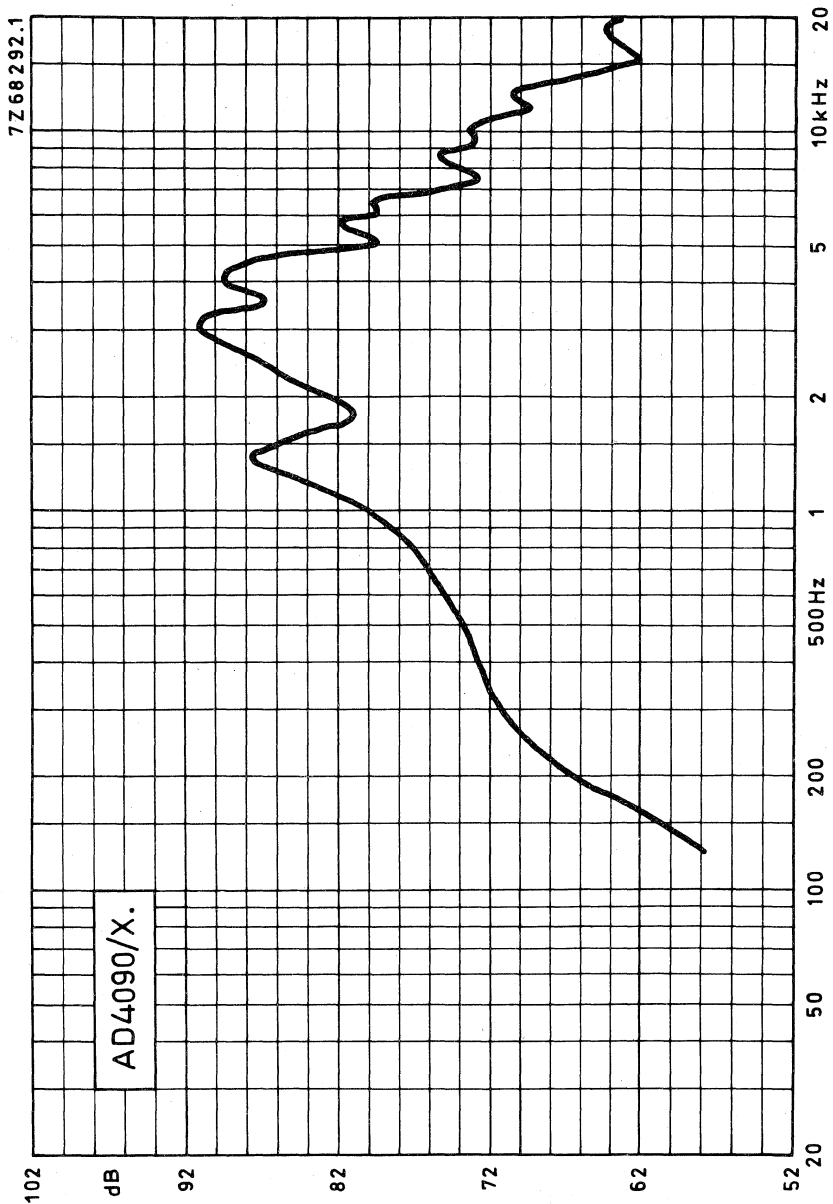

Fig. 2



4 inch MEDIUM POWER LOUDSPEAKER

APPLICATION

With its excellent power handling capacity very suitable for car radios.

TECHNICAL DATA

Rated impedance	4	Ω
Voice coil resistance	3, 4	Ω
Rated frequency range	90 to 14000	Hz
Resonance frequency	140	Hz
Power handling capacity, measured without filter loudspeaker unmounted	8	W
Operating power (sound level 90 dB, 1 m)	0, 8	W
Sweep voltage (80 to 20000 Hz)	3, 5	V
Energy in air gap	50	mJ
Flux density	0, 95	T
Air gap height	3	mm
Voice coil height	4, 4	mm
Core diameter	18	mm
Magnet material	Ferroxdure	
diameter	54	mm
mass	0, 1	kg
Mass of loudspeaker	0, 25	kg

The loudspeaker has a textile surround.

Dimensions (mm)

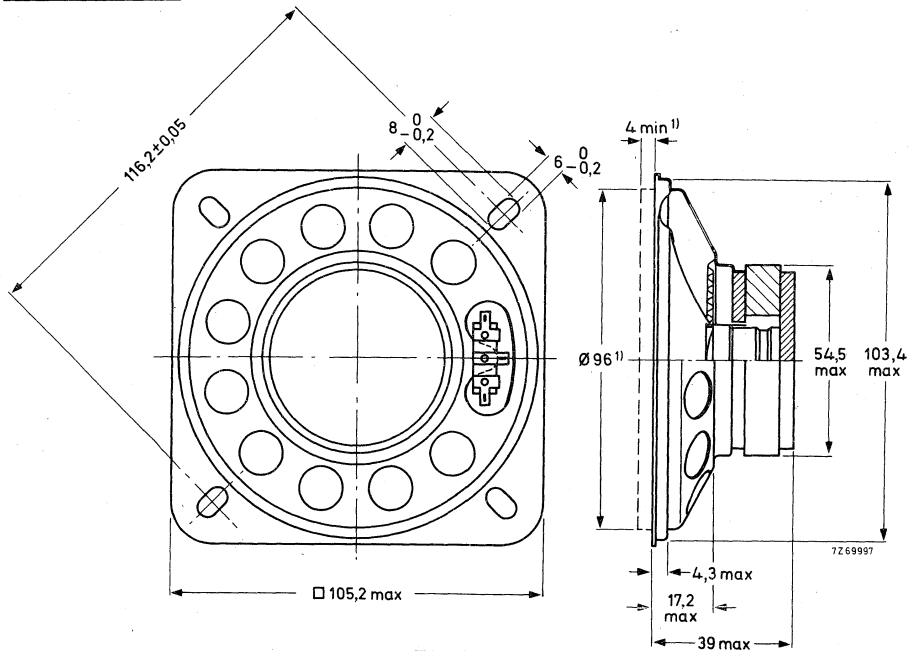

Fig. 1

¹) Baffle hole and clearance depth required for cone movement at the specified power handling capacity.

One tag is indicated by a red mark for in-phase connection.

AVAILABLE VERSION

AD4481/X4, catalogue number 2422 257 343.1

- (1 = stamped on loudspeaker magnet, not to be used for ordering)
- 3 = for bulk packing *)
- 7 = for single unit packing

FREQUENCY RESPONSE CURVES (see Fig. 2)

Curve b: Sound pressure measured in anechoic room, loudspeaker mounted on baffle according to IEC268-5, par. 4.4.

Curve c: 2nd and 3rd harmonic distortion, measured at the operating power of 0,8 W. Loudspeaker front mounted on IEC baffle.

*) Minimum packing quantity 9 per unit.

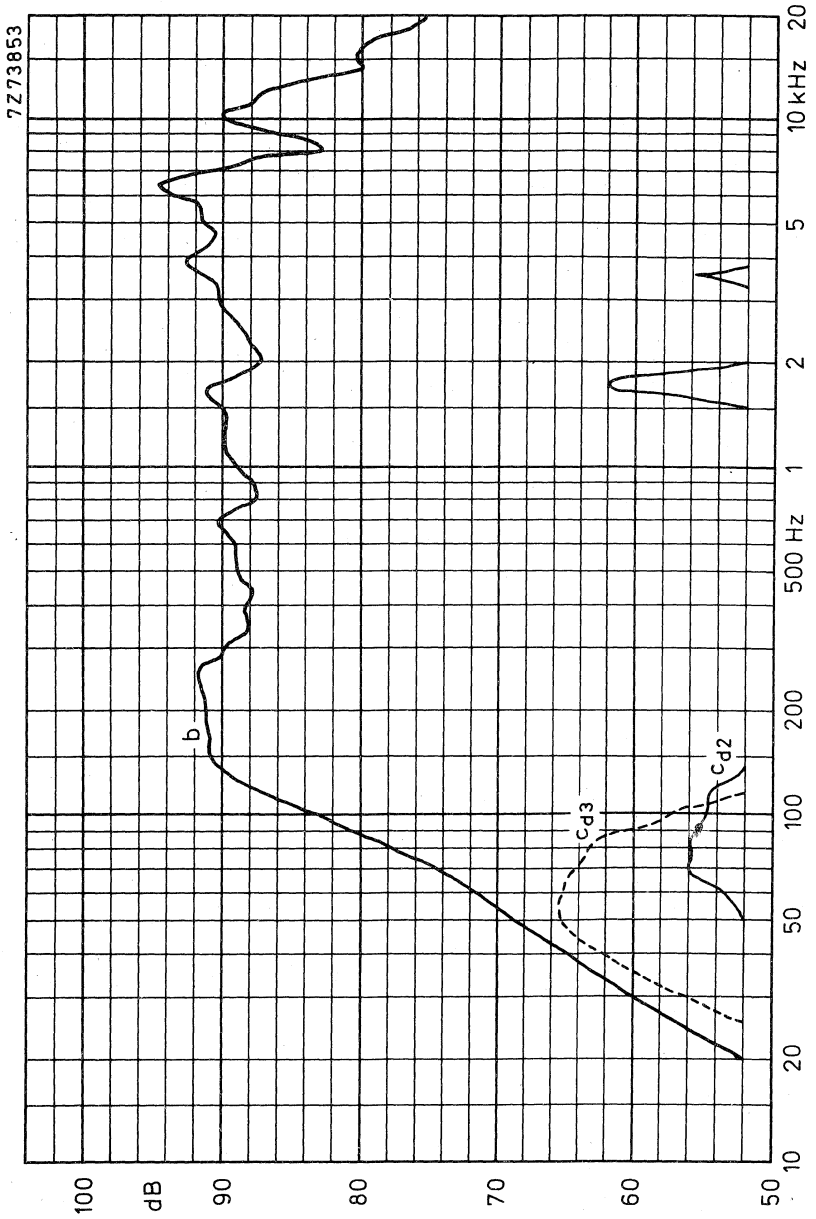

Fig. 2



4 × 6 inch OVAL MEDIUM POWER LOUDSPEAKER

APPLICATION

A full range loudspeaker for car and domestic radios, tape recorders and portable record players.

This speaker has an extended frequency response up to 20 kHz.

TECHNICAL DATA

	version		
	M4	M8	M25
Rated impedance	4	8	25 Ω
Voice coil resistance	3,4	7,1	22,7 Ω
Resonance frequency	135	135	135 Hz
Power handling capacity, measured without filter loudspeaker unmounted	6	6	6 W
Sweep voltage	2,8	4	7,1 V
Energy in airgap	55	55	55 mJ
Flux density	1	1	1 T
Airgap height	3	3	3 mm
Voice coil height	3	3,9	4 mm
Core diameter	18	18	18 mm
Magnet material	Fxd	Fxd	Fxd
diameter	53	53	53 mm
weight	0,1	0,1	0,1 kg
Weight of loudspeaker	0,26	0,26	0,26 kg

The loudspeaker has a paper cone and surround and a foam plastic gasket on the flange.

Dimensions (mm)

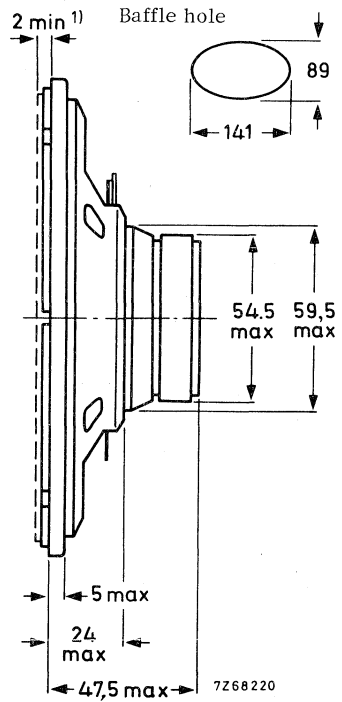
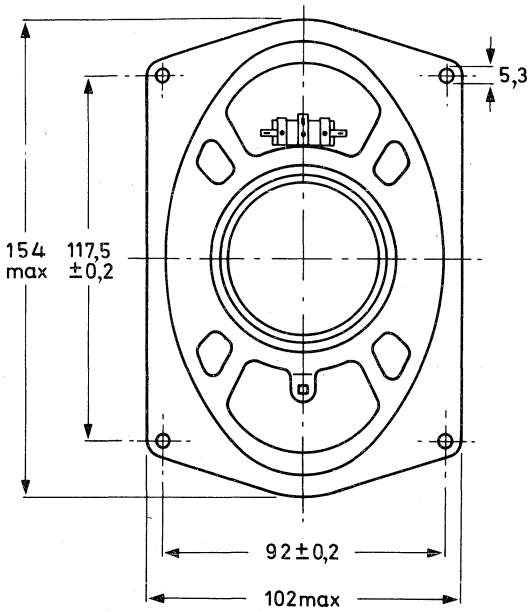

Fig. 1

1) Baffle hole and clearance depth required for cone movement at specified power handling capacity.

One tag is indicated by a red mark for in-phase connection.

AVAILABLE VERSIONS

- AD4681/M4, catalogue number 2422 257 304.9
- (0 = stamped on the loudspeaker magnet, not to be used for ordering)
 - 2 = for bulk packing *)
 - 6 = for single unit packing
- AD4681/M8, catalogue number 2422 257 304.1
- AD4681/M25, catalogue number 2422 257 304.3
- (1 = stamped on the loudspeaker magnet, not to be used for ordering)
 - 3 = for bulk packing *)
 - 7 = for single unit packing

FREQUENCY RESPONSE CURVE

Fig.2 Sound pressure measured in anechoic room, loudspeaker unmounted.
Above 1000 Hz the sensitivity may be, over the width of one octave, maximum 2 dB lower than indicated.
Input power 50 mW.

*) Minimum packing quantity 7 per unit.

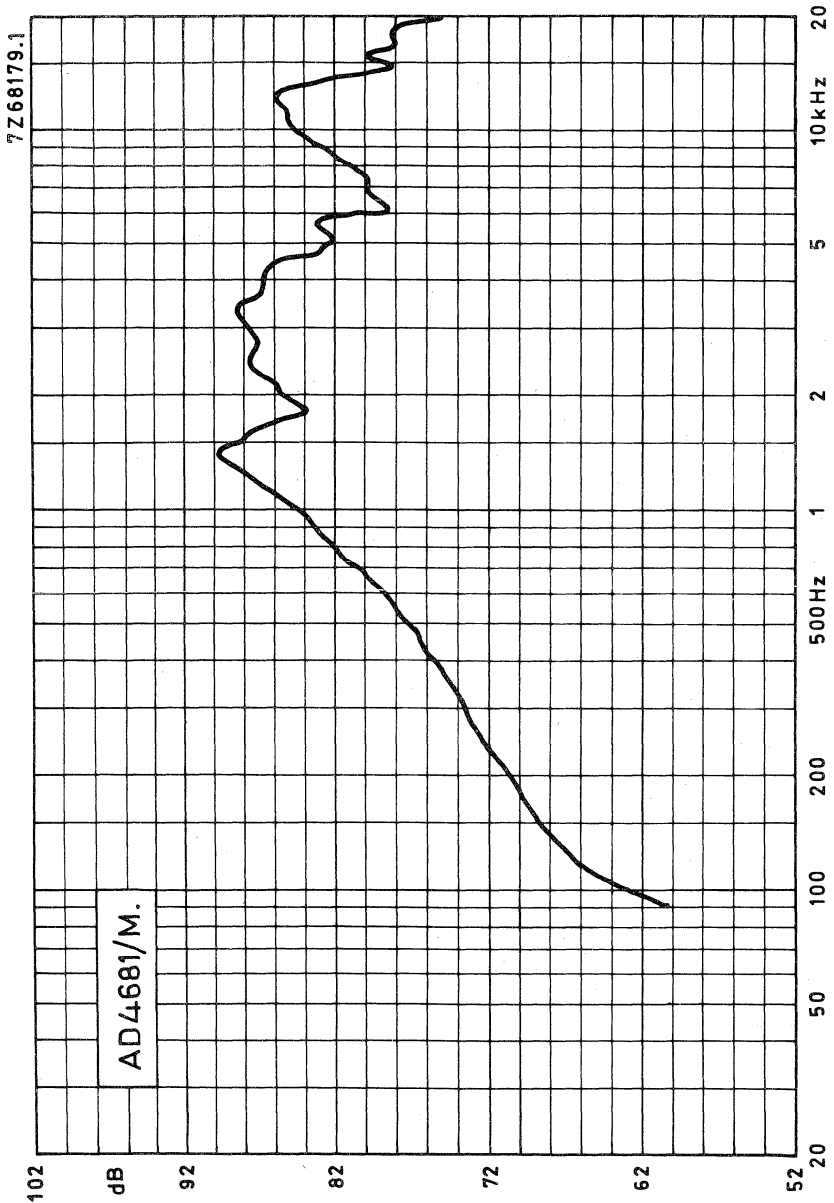

Fig.2

4 × 6 inch OVAL MEDIUM POWER LOUDSPEAKER

APPLICATION

For car and domestic radios, tape recorders and portables. Frequency range up to 12 kHz.
High sensitivity at 3000 Hz.

TECHNICAL DATA

	version				
	X4	X8	X15	X25	
Rated impedance	4	8	15	25	Ω
Voice coil resistance	3,1	7,1	13,5	22,7	Ω
Resonance frequency	140	140	140	140	Hz
Power handling capacity, measured without filter loudspeaker unmounted	6	6	6	6	W
Sweep voltage	3,5	4,9	6,7	8,7	V
Energy in airgap	55	55	55	55	mJ
Flux density	1	1	1	1	T
Airgap height	3	3	3	3	mm
Voice coil height	3	3,9	3,2	4	mm
Core diameter	18	18	18	18	mm
Magnet material	Fxd	Fxd	Fxd	Fxd	
diameter	53	53	53	53	mm
weight	0,1	0,1	0,1	0,1	kg
Weight of loudspeaker	0,26	0,26	0,26	0,26	kg

The loudspeaker has a paper cone and surround and a foam plastic gasket on the flange.

Dimensions (mm)

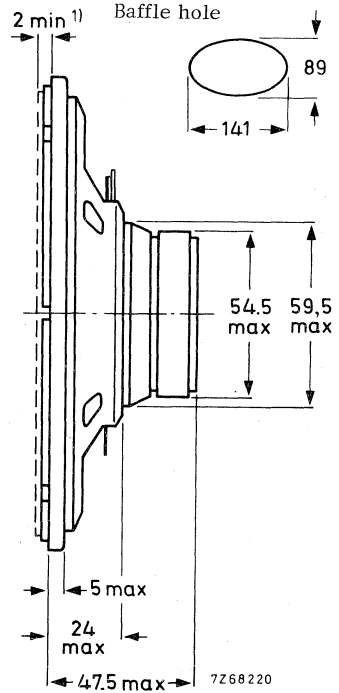
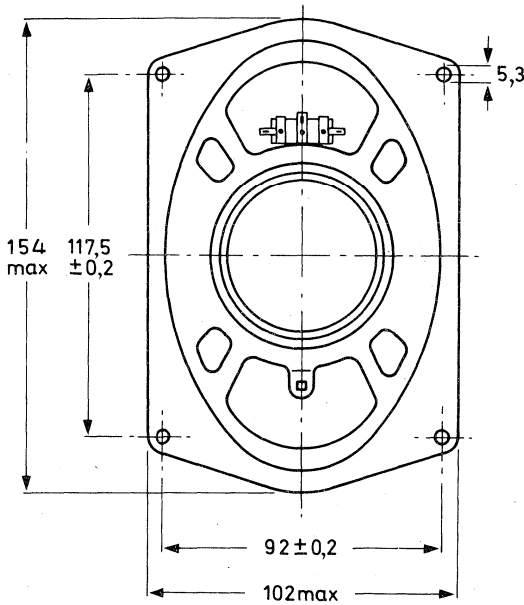

Fig. 1

1) Baffle hole and clearance depth required for cone movement at specified power handling capacity.

One tag is indicated by a red mark for in-phase connection.

AVAILABLE VERSIONS

- AD 4681/X4, catalogue number 2422 257 304.1
- AD 4681/X8, catalogue number 2422 257 304.2
- AD 4681/X15, catalogue number 2422 257 304.3
- AD 4681/X25, catalogue number 2422 257 304.4

(0 = stamped on loudspeaker magnet,
not to be used for ordering)

— 2 for bulk packing*)
— 6 for single unit packing

FREQUENCY RESPONSE CURVE

Fig. 2. Input power 50 mW
Sound pressure measured in anechoic room, loudspeaker unmounted. Above 1000 Hz the sensitivity may be, over the width of one octave, maximum 2 dB lower than indicated.

*) Minimum packing quantity 7 per unit.

4 x 6 inch OVAL MEDIUM POWER
LOUDSPEAKER

AD4681/X.

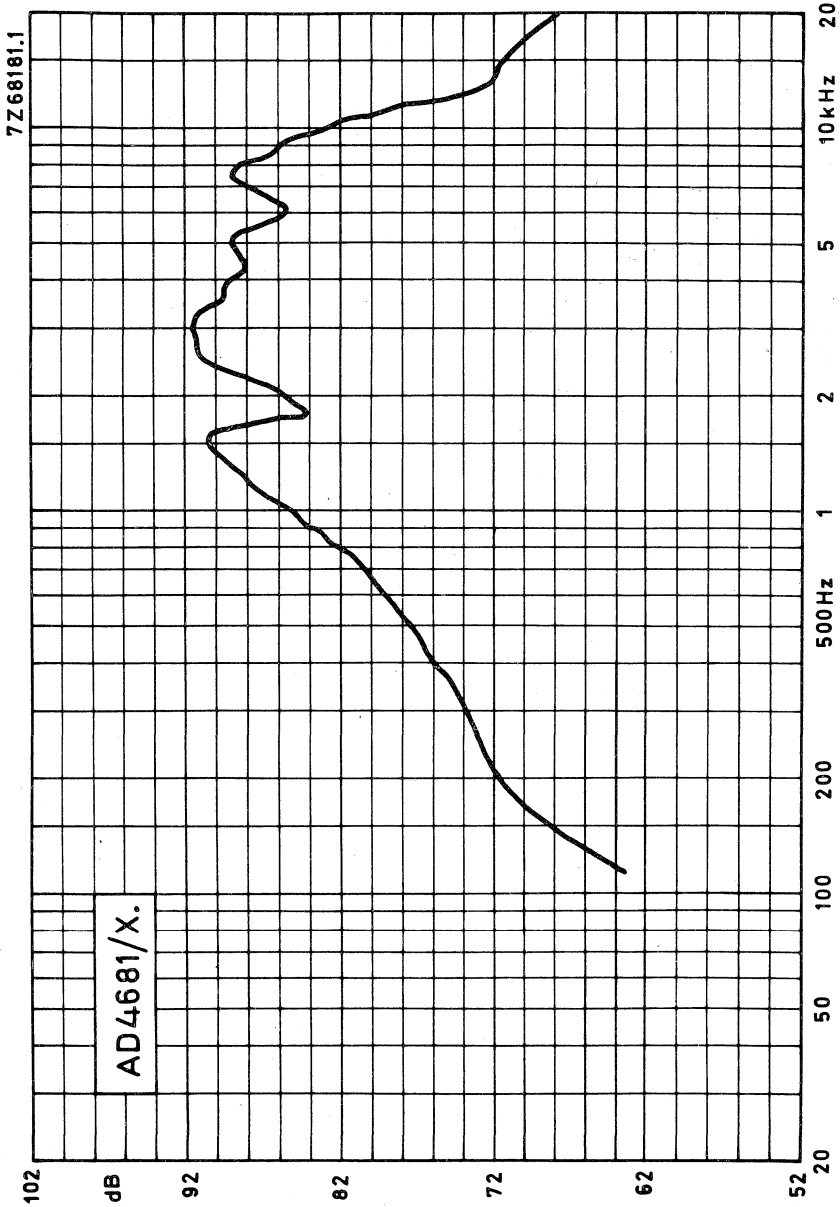

Fig. 2



DEVELOPMENT SAMPLE DATA

This information is derived from development samples made available for evaluation. It does not form part of our data handbook system and does not necessarily imply that the device will go into production

AD4682/X.

3½ x 6 inch OVAL MEDIUM POWER LOUDSPEAKERS

APPLICATION

For car and domestic radios, tape recorders, portable record players and intercoms.

TECHNICAL DATA

	version				
	X4	X8	X15	X25	
Rated impedance	4	8	15	25	Ω
Voice coil resistance	3,1	7,1	13,5	22,7	Ω
Rated frequency range	80 to 13 000				Hz
Resonance frequency	140				Hz
Power handling capacity, measured without filter, loudspeaker unmounted	6				W
Operating power (sound level 90 dB, 1 m)	0,7				W
Sweep voltage (70 to 20 000 Hz)	3,5	4,9	6,7	8,7	V
Energy in air gap	55				mJ
Flux density	1				T
Air-gap height	3				mm
Voice coil height	4,4	3,9	3,2	4	mm
Core diameter	18				mm
Magnet material	Ferroxdure				
diameter	54				mm
mass	0,1				kg
Mass of loudspeaker	0,25				kg

The loudspeaker has a paper rim and a foam plastic surround.

Dimensions (mm)

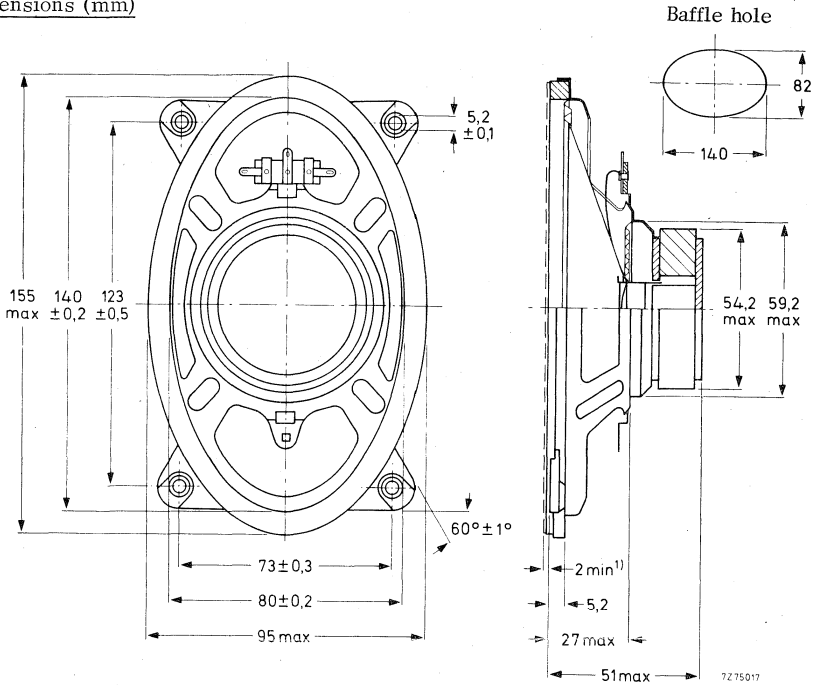

Fig. 1

1) Clearance depth required for cone movement at the specified power handling capacity. One tag is indicated by a red mark for in-phase connection.

AVAILABLE VERSIONS

- AD4682/X4, catalogue number 2422 257 306. 1
 - AD4682/X8, catalogue number 2422 257 306. 2
 - AD4682/X15, catalogue number 2422 257 306. 3
 - AD4682/X25, catalogue number 2422 257 306. 4
- (0 = stamped on loudspeaker magnet, not to be used for ordering)
- 2 = for bulk packing *)
 - 6 = for single unit packing

FREQUENCY RESPONSE CURVES (see Fig. 2)

Curve b: Sound pressure measured in anechoic room, loudspeaker mounted on baffle according to IEC268-5, par. 4. 4.

Curve c: 2nd and 3rd harmonic distortion, measured at the operating power of 0,7 W in anechoic room. Loudspeaker front mounted on IEC baffle.

*) Minimum packing quantity 7 per unit.

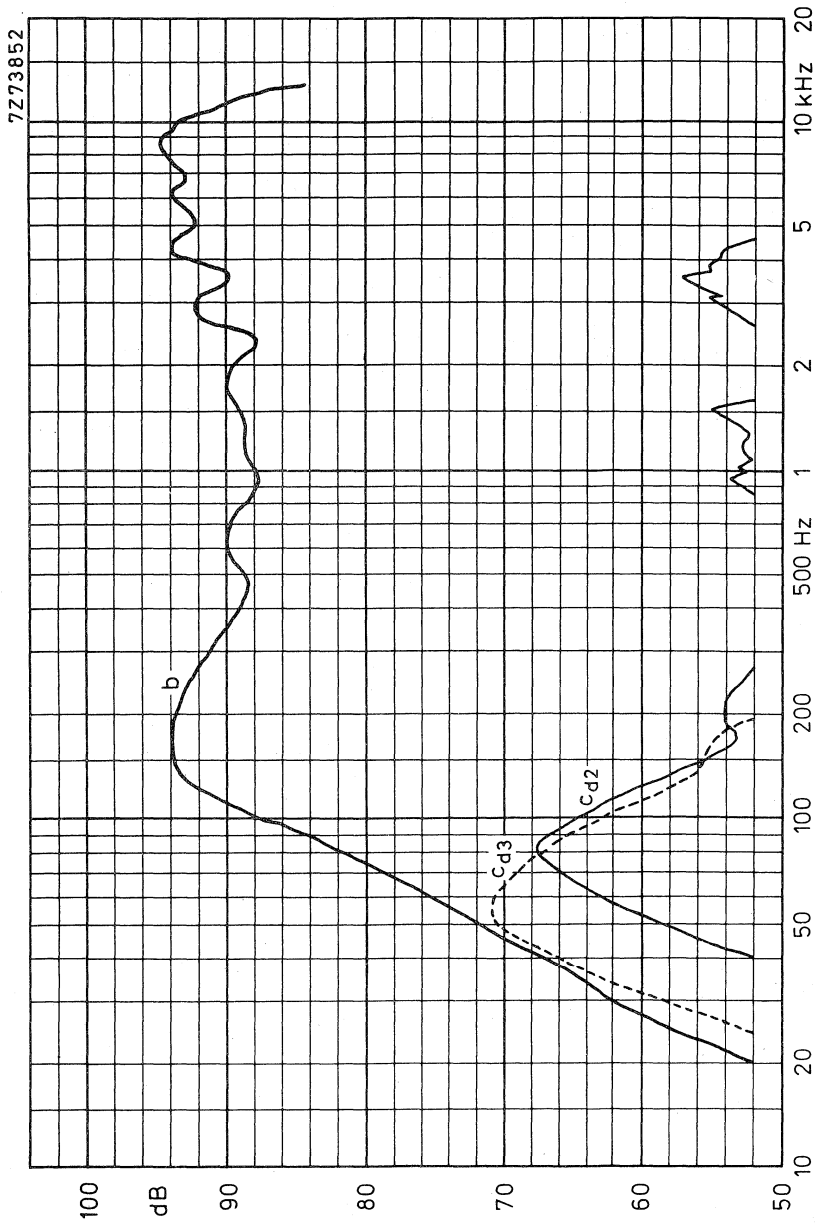

Fig. 2



4 × 6 inch OVAL MEDIUM POWER LOUDSPEAKER

APPLICATION

A full range loudspeaker with an extended frequency response up to 20 kHz. Due to absence of stray ticonal sinterpot magnetic field, this loudspeaker can be used for black and white as well as colour television sets.

TECHNICAL DATA

	version				
	M4	M8	M15	M25	M800
Rated impedance	4	8	15	25	800 Ω
Voice coil resistance	3,4	7,1	13,5	22,7	600 Ω
Resonance frequency	135	135	135	135	135 Hz
Power handling capacity, measured without filter loudspeaker unmounted	4	4	4	4	4 W
Sweep voltage	2,8	4	5,5	7,1	40 V
Energy in airgap	39	39	39	39	39 mJ
Flux density	0,8	0,8	0,8	0,8	0,8 T
Airgap height	3	3	3	3	3 mm
Voice coil height	3	3,9	3,2	4	5,1 mm
Core diameter	18	18	18	18	18 mm
Magnet material	Ticonal	Ticonal	Ticonal	Ticonal	Ticonal
diameter	18	18	18	18	18 mm
weight	0,027	0,027	0,027	0,027	0,027 kg
Weight of loudspeaker	0,16	0,16	0,16	0,16	0,16 kg

The loudspeaker has a paper cone and surround and a foam plastic gasket on the flange.

Dimensions (mm)

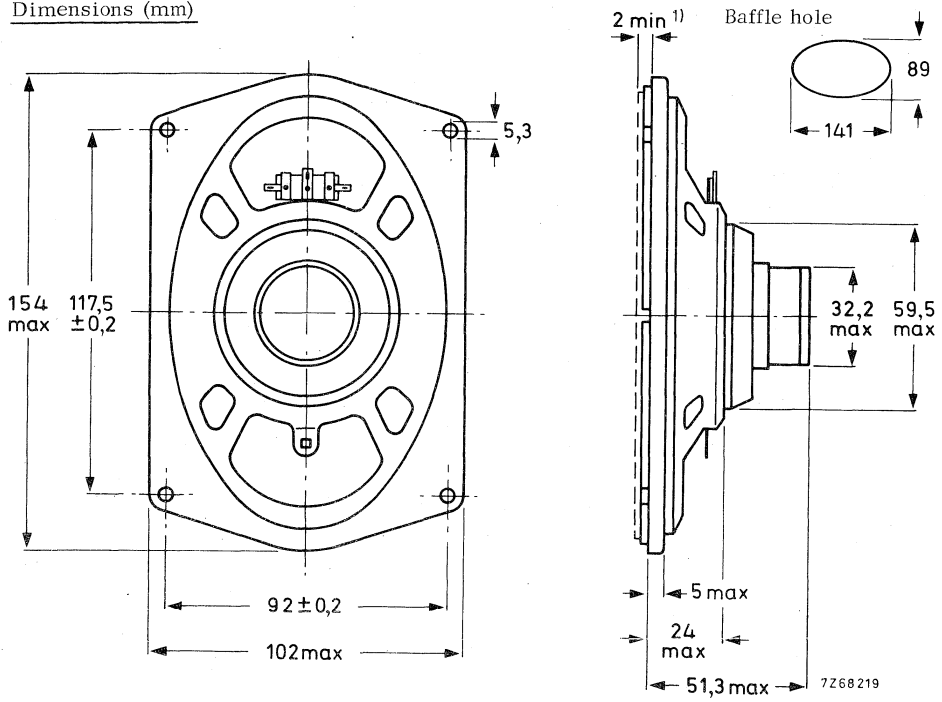

Fig. 1

1) Baffle hole and clearance depth required for cone movement at the specified power handling capacity.

One tag is indicated by a red mark for in-phase connection.

AVAILABLE VERSIONS

- AD4691/M4, catalogue number 2422 256 306.2
 - AD4691/M8, catalogue number 2422 256 306.5
 - AD4691/M15, catalogue number 2422 256 306.4
 - AD4691/M25, catalogue number 2422 256 306.6
 - AD4691/M800, catalogue number 2422 256 306.3
- (1 = stamped on loudspeaker magnet,
not to be used for ordering)
- 3 = for bulk packing *)
7 = for single unit packing

FREQUENCY RESPONSE CURVE

Fig. 2 Sound pressure measured in anechoic room, loudspeaker unmounted.
Above 1000 Hz the sensitivity may be, over the width of one octave, maximum
2 dB lower than indicated.
Input power 50 mW

*) Minimum packing quantity 7 per unit.

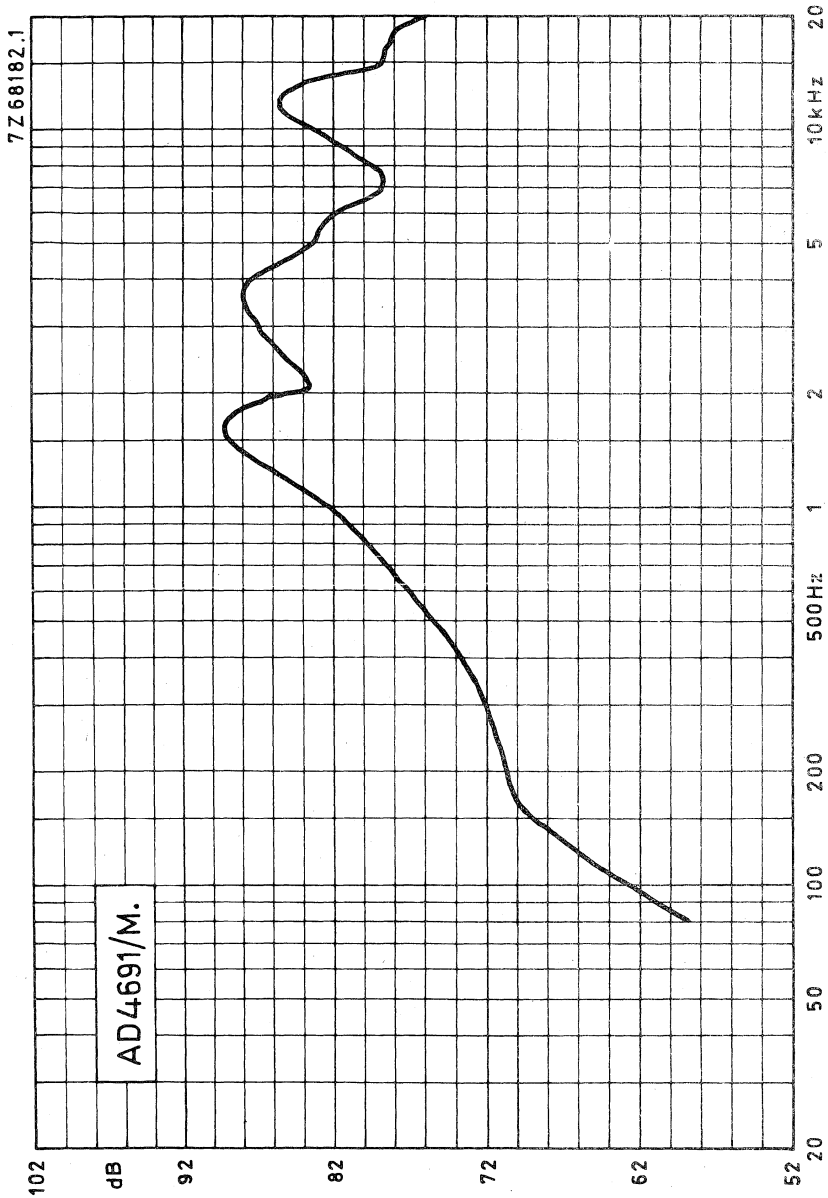

Fig. 2

4 × 6 inch OVAL MEDIUM POWER LOUDSPEAKER

APPLICATION

Due to absence of stray magnetic ticonal sinterpot field, the loudspeaker can be used in black and white as well as colour television sets.

High sensitivity at 3000 Hz. Frequency response up to 12 kHz.

TECHNICAL DATA

	version				
	X4	X8	X15	X25	
Rated impedance	4	8	15	25	Ω
Voice coil resistance	3,4	7,1	13,5	22,7	Ω
Resonance frequency	140	140	140	140	Hz
Power handling capacity, measured without filter, loudspeaker unmounted	4	4	4	4	W
Sweep voltage	2,8	4	5,5	7,1	V
Energy in airgap	39	39	39	39	mJ
Flux density	0,8	0,8	0,8	0,8	T
Airgap height	3	3	3	3	mm
Voice coil height	3	3,9	3,2	4	mm
Core diameter	18	18	18	18	mm
Magnet material	Ticonal	Ticonal	Ticonal	Ticonal	
diameter	18	18	18	18	mm
weight	0,027	0,027	0,027	0,027	kg
Weight of loudspeaker	0,16	0,16	0,16	0,16	kg

The loudspeaker has a paper cone and surround and a foam plastic gasket on the flange.

Dimensions (mm)

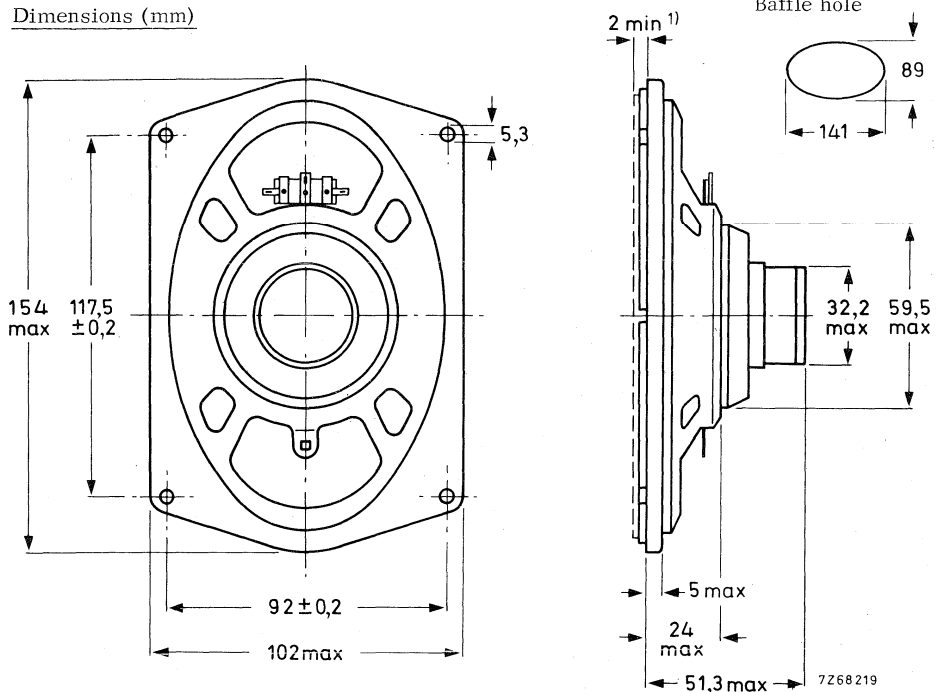

Fig. 1

1) Baffle hole and clearance depth required for cone movement at the specified power handling capacity.

One tag is indicated by a red mark for in-phase connection.

AVAILABLE VERSIONS

- AD 4691/X4, catalogue number 2422 256 306.1
- AD 4691/X8, catalogue number 2422 256 306.2
- AD 4691/X15, catalogue number 2422 256 306.3
- AD 4691/X25, catalogue number 2422 256 306.4

(0 = stamped on loudspeaker magnet,
not to be used for ordering)

- 2 for bulk packing*)
- 6 for single unit packing

FREQUENCY RESPONSE CURVE

Fig. 2. Input power 50 mW
Sound pressure measured in anechoic room, loudspeaker unmounted.
Above 1000 Hz sensitivity may be, over the width of one octave, maximum 2 dB lower than indicated.

*) Minimum packing quantity 7 per unit.

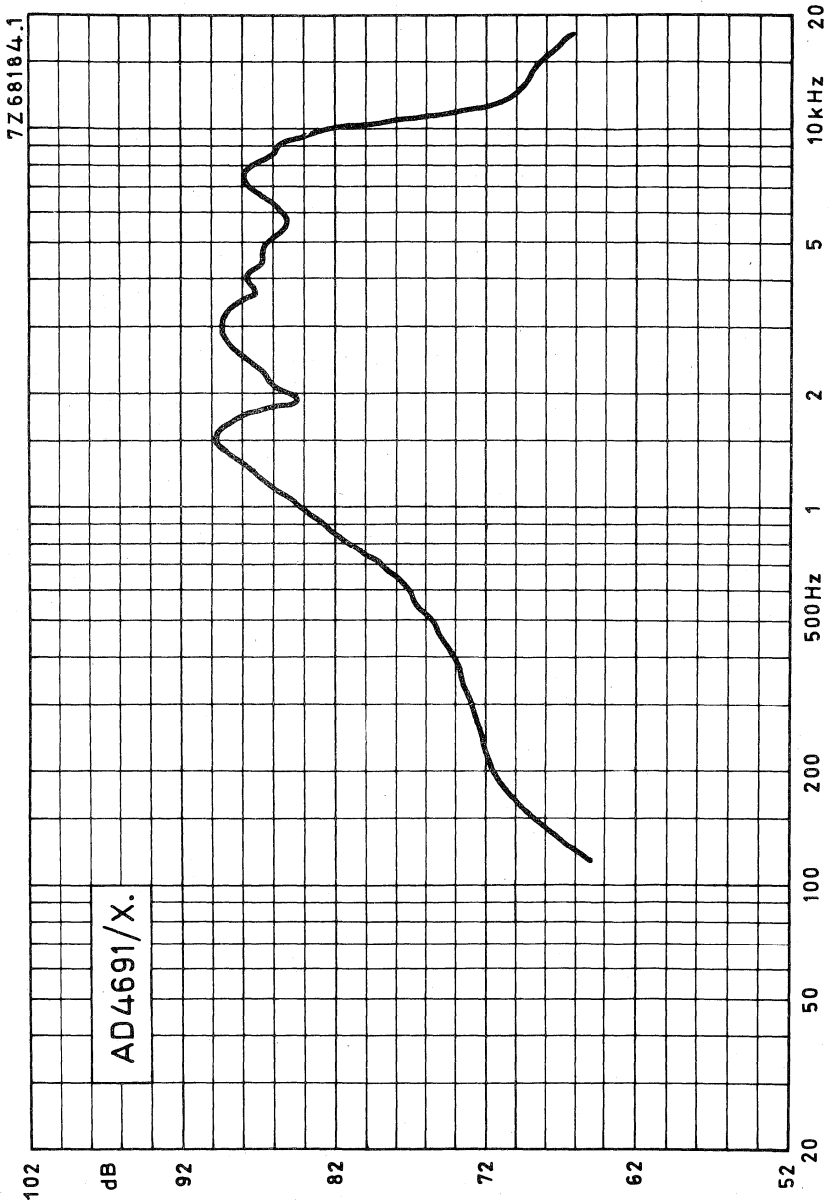

Fig. 2



DEVELOPMENT SAMPLE DATA

This information is derived from development samples made available for evaluation. It does not form part of our data handbook system and does not necessarily imply that the device will go into production

AD4692/X.**3½ x 6 inch OVAL MEDIUM POWER LOUDSPEAKERS****APPLICATION**

For colour television sets. Low stray field and high sensitivity.

TECHNICAL DATA

	version				
	X4	X8	X15	X25	
Rated impedance	4	8	15	25	Ω
Voice coil resistance	3,1	7,1	13,5	22,7	Ω
Rated frequency range	80 to 13 000				Hz
Resonance frequency	140				Hz
Power handling capacity, measured without filter, loudspeaker unmounted	4				W
Operating power (sound level 90 dB, 1 m)	1				W
Sweep voltage (70 to 20 000 Hz)	2,8	4	5,5	7,1	V
Energy in air gap	39				mJ
Flux density	0,8				T
Air gap height	3				mm
Voice coil height	3	3,9	3,2	4	mm
Core diameter	18				mm
Magnet material	Ticonal				
diameter	18				mm
mass	0,027				kg
Mass of loudspeaker	0,14				kg

The loudspeaker has a paper rim and a foam plastic gasket.

Dimensions (mm)

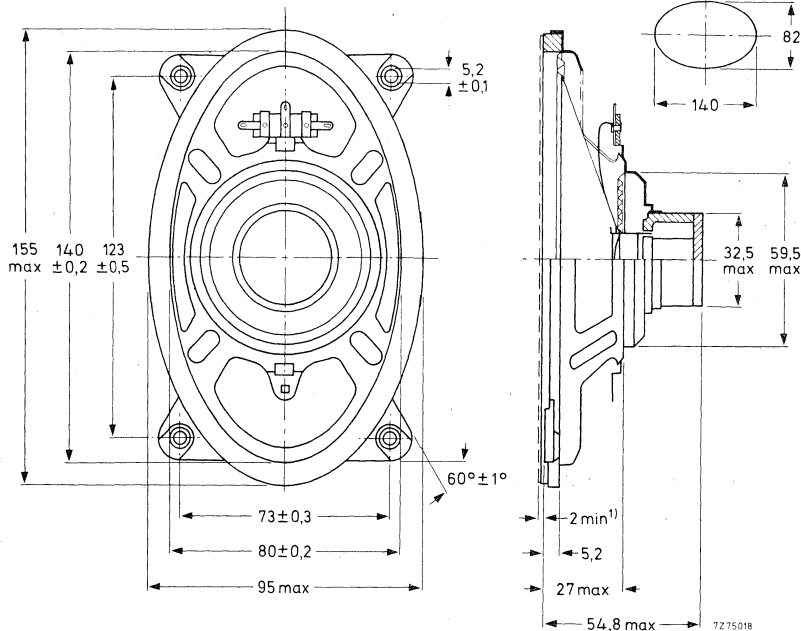

Fig. 1

1) Clearance depth required for cone movement at the specified power handling capacity.

One tag is indicated by a red mark for in-phase connection.

AVAILABLE VERSIONS

- AD4692/X4, catalogue number 2422 256 308.1
- AD4692/X8, catalogue number 2422 256 308.2
- AD4692/X15, catalogue number 2422 256 308.3
- AD4692/X25, catalogue number 2422 256 308.4

(0 = stamped on loudspeaker magnet, not to be used for ordering)

2 = for bulk packing *)
6 = for single unit packing

FREQUENCY RESPONSE CURVES (see Fig. 2)

Curve b: Sound pressure measured in anechoic room, loudspeaker mounted on baffle according to IEC268-5, par. 4.4.

Curve c: 2nd and 3rd harmonic distortion, measured at the operating power of 1 W in anechoic room. Loudspeaker front mounted on IEC baffle.

*) Minimum packing quantity 7 per unit.

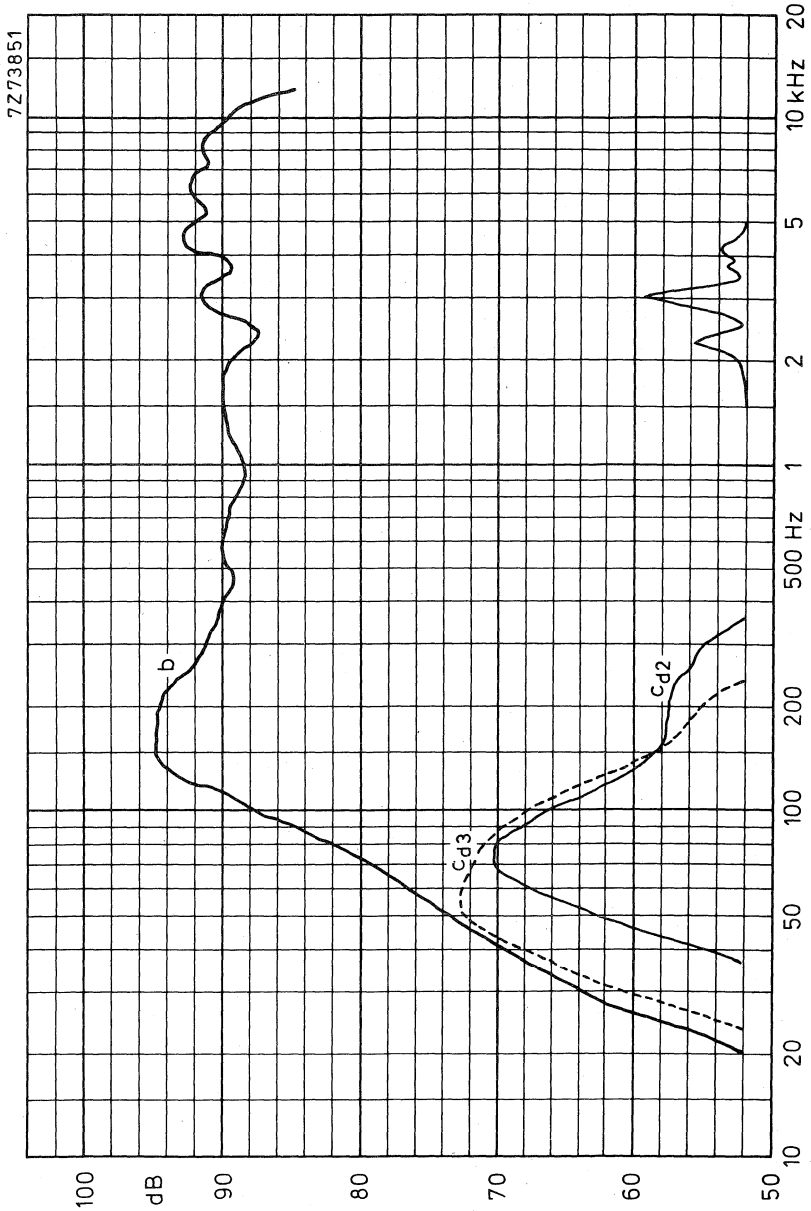

Fig.2



4 x 8 inch OVAL MEDIUM POWER LOUDSPEAKERS

APPLICATION

For colour television sets. Low stray field, low resonance frequency, high sensitivity in bass region.

TECHNICAL DATA

	version				
	X4	X8	X15	X25	
Rated impedance	4	8	15	25	Ω
Voice coil resistance	3,4	7,1	13,5	22,7	Ω
Rated frequency range	55 to 13 000				Hz
Resonance frequency	110				Hz
Power handling capacity, measured without filter, loudspeaker unmounted	8				W
Operating power (sound level 90 dB, 1 m)	0,7				W
Sweep voltage (55 to 20 000 Hz)	4	5,7	7,8	10	V
Energy in air gap	39				mJ
Flux density	0,8				T
Air gap height	3				mm
Voice coil height	4,5	3,9	3,2	4	mm
Core diameter	18				mm
Magnet material	Ticonal				
diameter	18				mm
mass	0,027				kg
Mass of loudspeaker	0,23				kg

The loudspeaker has a paper rim and a foam plastic gasket.

Dimensions (mm)

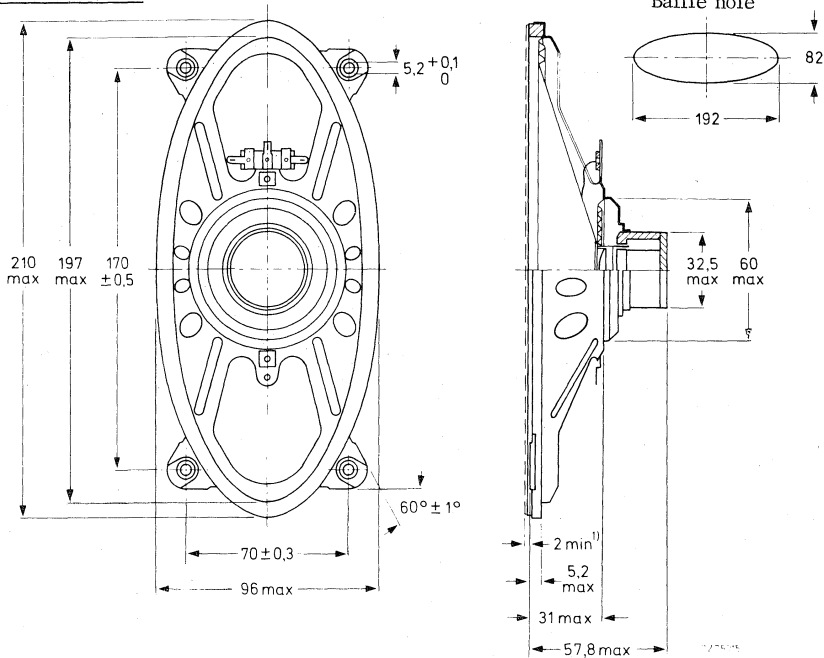

Fig. 1

1) Clearance depth required for cone movement at the specified power handling capacity. One tag is indicated by a red mark for in-phase connection.

AVAILABLE VERSIONS

- AD4890/X4, catalogue number 2422 256 307.1
- AD4890/X8, catalogue number 2422 256 307.2
- AD4890/X15, catalogue number 2422 256 307.3
- AD4890/X25, catalogue number 2422 256 307.4

(0 = stamped on loudspeaker magnet, not to be used for ordering)

2 = for bulk packing*)
6 = for single unit packing

FREQUENCY RESPONSE CURVES (see Fig. 2)

Curve b: Sound pressure measured in anechoic room, loudspeaker mounted on baffle according to IEC268-5, par. 4. 4.

Curve c: 2nd and 3rd harmonic distortion, measured at the operating power of 0,7 W in anechoic room. Loudspeaker front mounted on IEC baffle.

*) Minimum packing quantity 5 per unit.

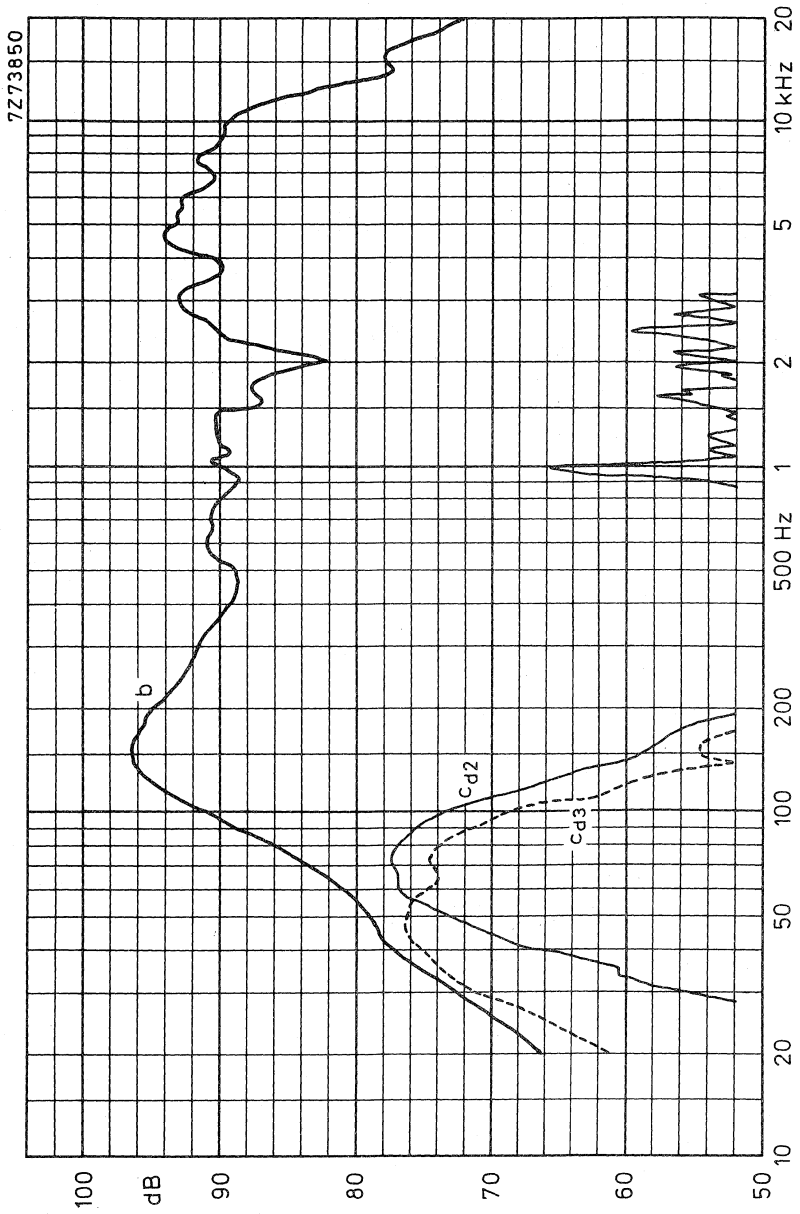

Fig. 2



5 inch HIGH POWER SQUAWKER LOUDSPEAKER

APPLICATION

For the reproduction of audio frequencies from 500 to 4500 Hz with very low distortion ← in multi-way high-fidelity loudspeaker systems in accordance with DIN45500. The loudspeaker has an excellent spherical radiation pattern. Rated frequency range 500 to 5000 Hz.

TECHNICAL DATA

	version		
	Sq4	Sq8	
Rated impedance	4	8	Ω
Voice coil resistance	3,4	6,4	Ω
Resonance frequency	210	210	Hz
Power handling capacity			
measured with filter: 72 μF - 2,1 mH (4Ω)	40	-	W
36 μF - 4,5 mH (8Ω)	-	40	W
loudspeaker unmounted			
Operating power	4	4	W
Sweep voltage			
frequency range: 400 - 5000 Hz			
filter high pass : 72 μF - 2,1 mH (4Ω)	3,5	-	V
36 μF - 4,5 mH (8Ω)	-	5	V
Energy in air gap	140	140	mJ
Flux density	0,93	0,93	T
Air-gap height	5	5	mm
Voice coil height	6,8	6,8	mm
Core diameter	25	25	mm
Magnet material	FXD	FXD	
diameter	72	72	mm
mass	0,23	0,23	kg
Mass of loudspeaker	0,8	0,8	kg

The loudspeaker has a rubber surround and a sealed pot; no acoustic isolation required. Connection to the loudspeaker is by means of 6,3 mm (0,25 inch) Fastons or soldering.

Dimensions (mm)

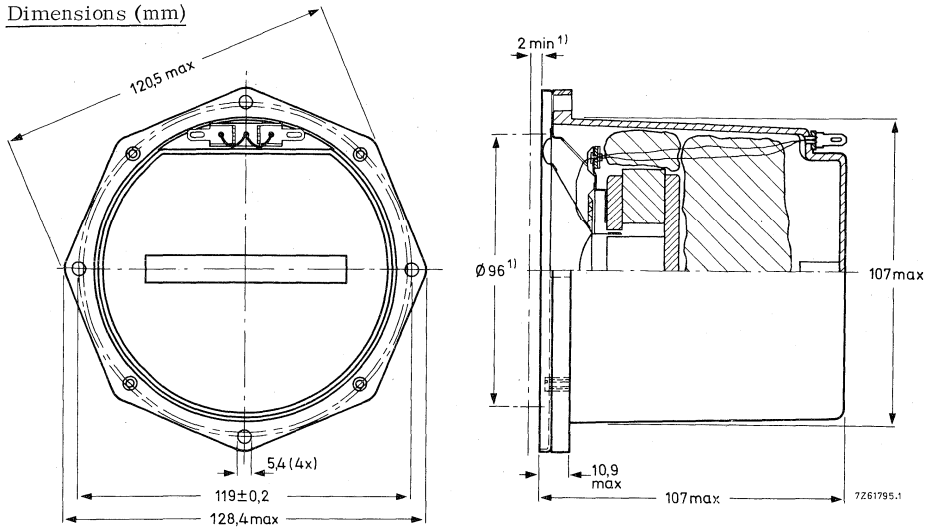

Fig. 1

1) Baffle hole and clearance depth required for cone movement at the specified power handling capacity.

One tag is indicated by a red mark for in-phase connection.

AVAILABLE VERSIONS

AD5060/Sq4, catalogue number 2422 257 354.1

AD5060/Sq8, catalogue number 2422 257 354.2

(0 = stamped on loudspeaker magnet
not to be used for ordering)

2 = for bulk packing *)

6 = for single unit packing

FREQUENCY RESPONSE CURVES (see Fig. 2)

Curve b: Sound pressure measured in half free field at operating power of 4 W in anechoic room, loudspeaker mounted on IEC baffle.

Curve c: 2nd and 3rd harmonic distortion, measured at the operating power of 4 W in anechoic room.

*) Minimum packing quantity 6 per unit.

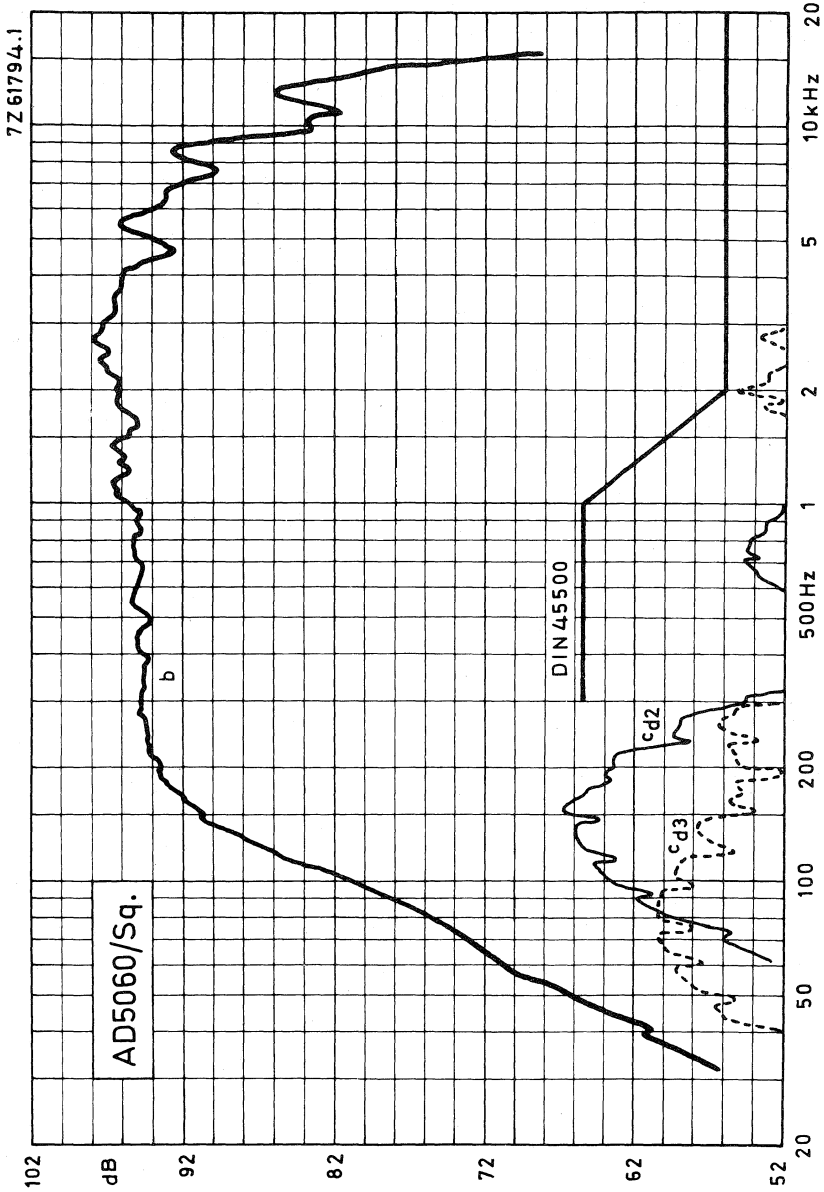

Fig. 2



5 inch HIGH POWER FULL RANGE LOUDSPEAKER

APPLICATION

A full range loudspeaker for small sealed enclosures of maximum 7 litres and also suitable for use in bookshelves enclosures.

Extended frequency response 75 - 20 kHz in 7 litres enclosures.

TECHNICAL DATA

	version		
	M4	M8	
Rated impedance	4	8	Ω
Voice coil resistance	3,4	7	Ω
Resonance frequency	85	85	Hz
Power handling capacity measured without filter, loudspeaker unmounted	10	10	W
Operating power	2	2	W
Sweep voltage	3,2	4,5	V
Energy in airgap	127	127	mJ
Flux density	0,87	0,87	T
Airgap height	5	5	mm
Voice coil height	6,5	6,5	mm
Core diameter	25	25	mm
Magnet material	Fxd	Fxd	
diameter	72	72	mm
weight	0,26	0,26	kg
Weight of loudspeaker	0,665	0,665	kg

The loudspeaker has a textile surround and a foam plastic gasket on the flange.

Dimensions (mm)

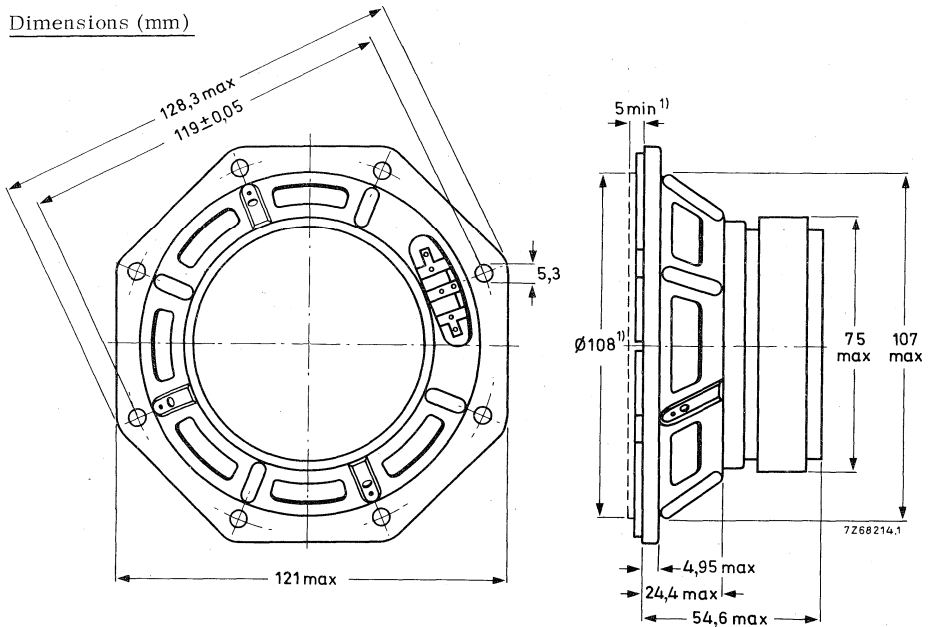

Fig. 1

1) Baffle hole and clearance depth required for cone movement at the specified power handling capacity.

One tag is indicated by a red mark for in-phase connection.

AVAILABLE VERSIONS

AD 5061/M4. catalogue number 2422 257 355. 1

AD 5061/M8. catalogue number 2422 257 355. 2

(0 = stamped on loudspeaker magnet
not to be used for ordering)

2 for bulk packing*)
6 for single unit packing

FREQUENCY RESPONSE CURVE

Curve b : Sound pressure measured in anechoic room at input power of 2 W.
Loudspeaker mounted on IEC baffle.

*) Minimum packing quantity 6 per unit.

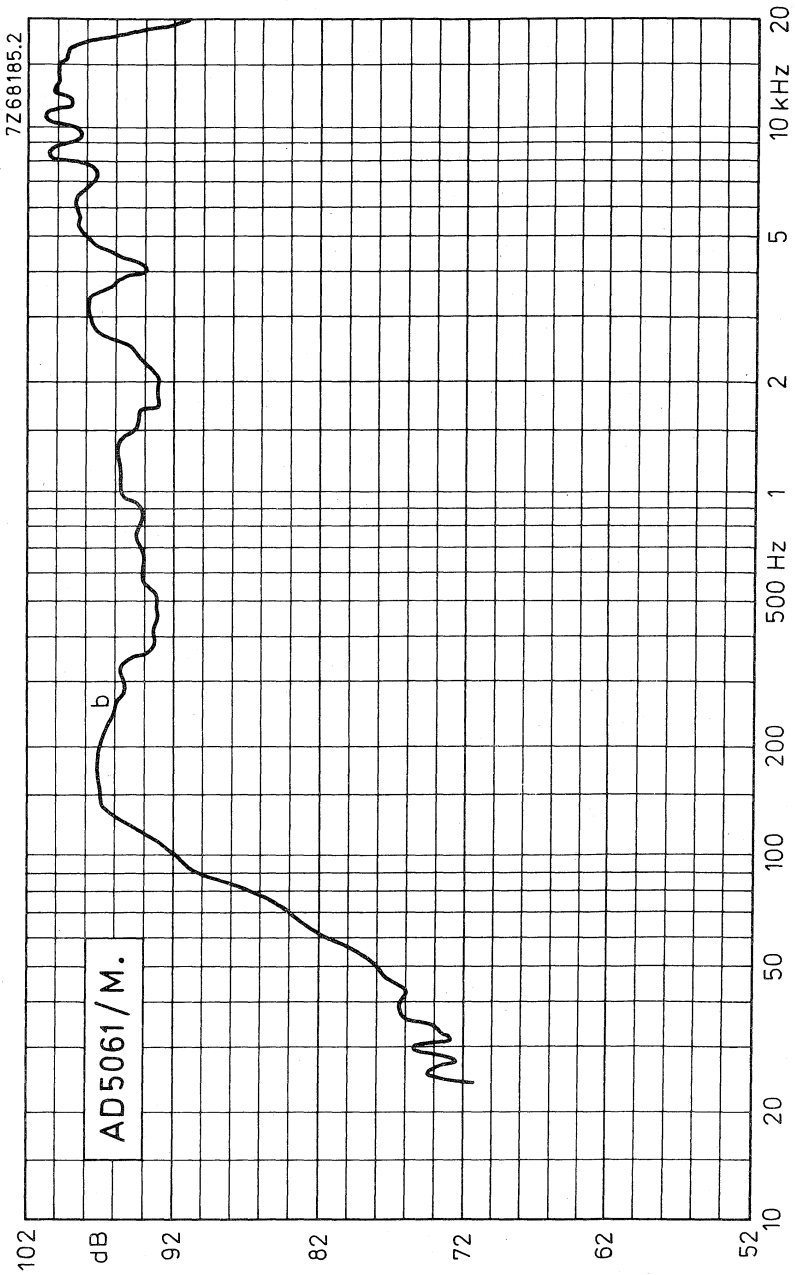

Fig. 2



Dimensions (mm)

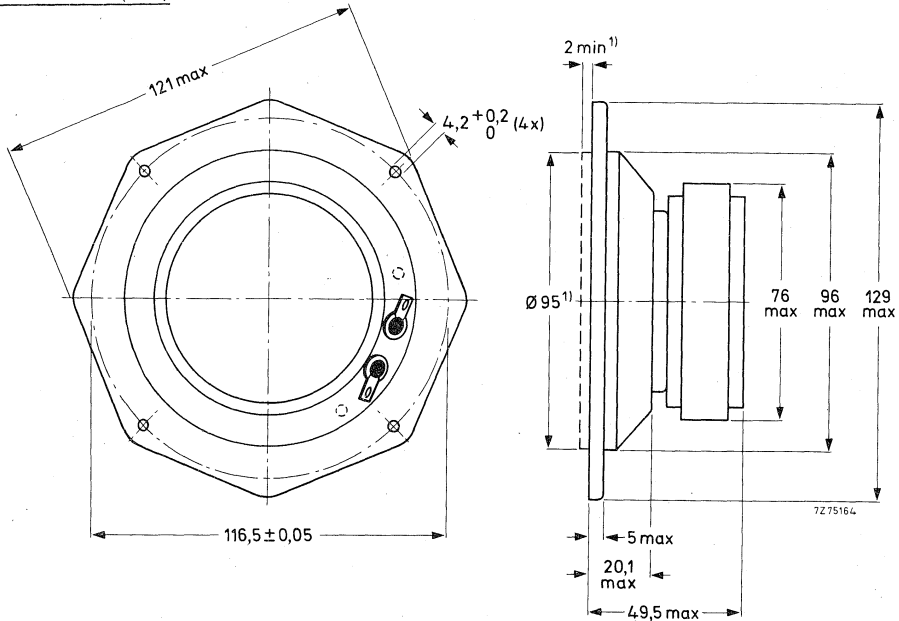

Fig. 1

¹⁾ Baffle hole and clearance depth required for cone movement at the specified power handling capacity.

One tag is indicated by a red mark for in-phase connection.

AVAILABLE VERSIONS

AD5061/Sq4, catalogue number 2422 257 354.5

AD5061/Sq8, catalogue number 2422 257 354.6

(0 = stamped on loudspeaker magnet
not to be used for ordering)

2 = for bulk packing*)

6 = for single unit packing

FREQUENCY RESPONSE CURVES (see Fig. 2)

Curve b: Sound pressure measured in half free field at operating power of 2 W in anechoic room, loudspeaker mounted on IEC baffle.

Curve c: 2nd and 3rd harmonic distortion, measured at the operating power of 2 W in anechoic room.

*) Minimum packing quantity 6 per unit.

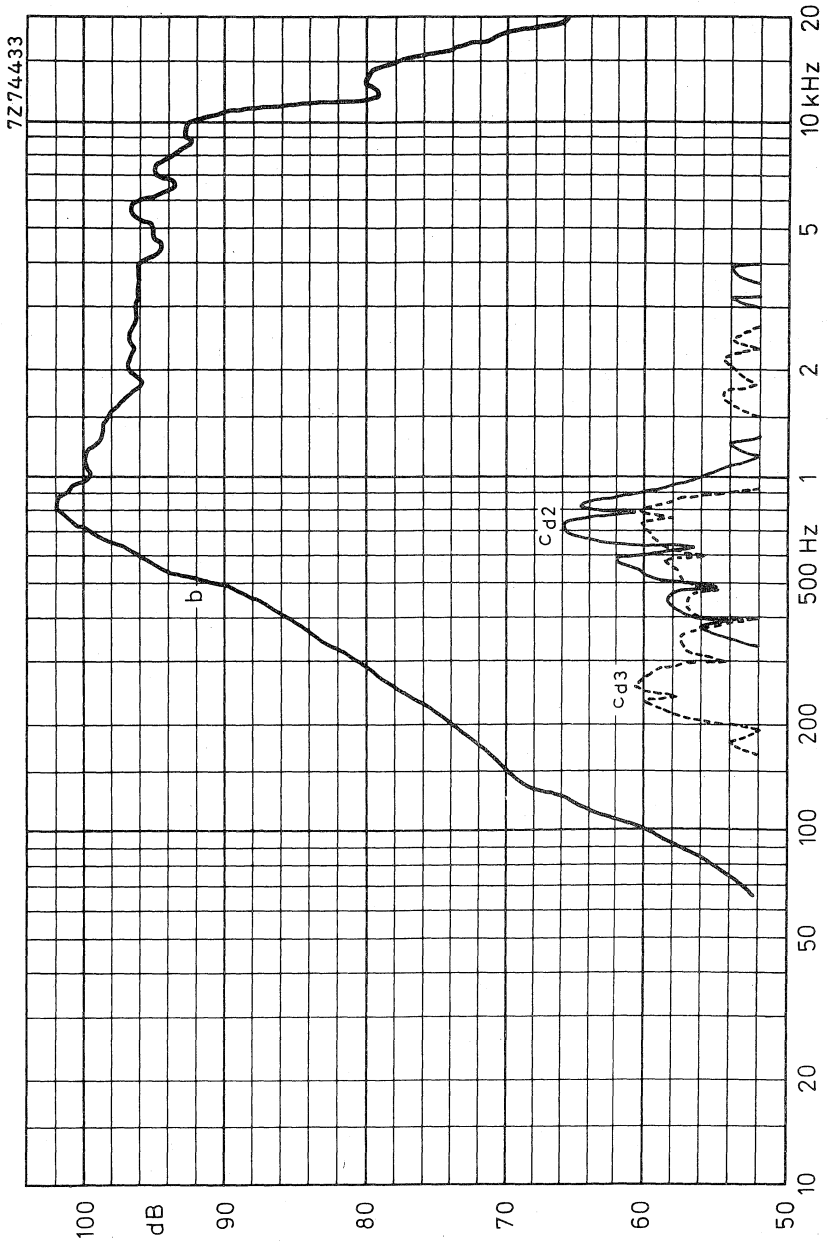

Fig. 2



DEVELOPMENT SAMPLE DATA

This information is derived from development samples made available for evaluation. It does not form part of our data handbook system and does not necessarily imply that the device will go into production

AD5081/M.

5 inch ROUND MEDIUM POWER LOUDSPEAKERS

APPLICATION

Double cone loudspeaker for car and domestic radios, tape recorders, portable record players and intercoms.

TECHNICAL DATA

	version				
	M4	M8	M15	M25	
Rated impedance	4	8	15	25	Ω
Voice coil resistance	3,4	7,1	13,5	22,7	Ω
Rated frequency range	70 to 20 000				Hz
Resonance frequency	135				Hz
Power handling capacity, measured without filter, loudspeaker unmounted	6				W
Operating power (sound level 90 dB, 1 m)	0,7				W
Sweep voltage (70 to 20 000 Hz)	3,5	4,9	6,7	8,7	V
Energy in air gap	55				mJ
Flux density	1				T
Air-gap height	3				mm
Voice coil height	4,4	3,6	3,2	4	mm
Core diameter	18				mm
Magnet material	Ferroxdure				
diameter	53				mm
mass	0,1				kg
Mass of loudspeaker	0,25				kg

The loudspeaker has a paper surround and a foam plastic gasket on the flange.

Dimensions (mm)

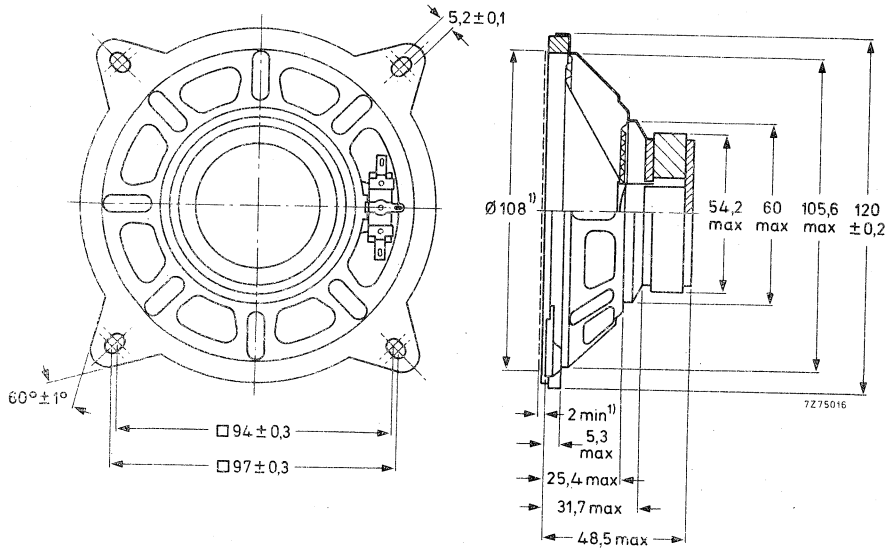

Fig. 1

1) Baffle hole and clearance depth required for cone movement at the specified power handling capacity.

One tag is indicated by a red mark for in-phase connection.

AVAILABLE VERSIONS

- AD5081/M4, catalogue number 2422 257 357.5
- AD5081/M8, catalogue number 2422 257 357.6
- AD5081/M15, catalogue number 2422 257 357.7
- AD5081/M25, catalogue number 2422 257 357.8

(0 = stamped on loudspeaker magnet,
not to be used for ordering)

2 = for bulk packing*)
6 = for single unit packing

FREQUENCY RESPONSE CURVES (see Fig. 2)

Curve b: Sound pressure measured in anechoic room, loudspeaker mounted on baffle according to IEC268-5, par. 4.4.

Curve c: 2nd and 3rd harmonic distortion, measured at the operating power of 0,7 W in anechoic room. Loudspeaker front mounted on IEC baffle.

*) Minimum packing quantity 6 per unit.

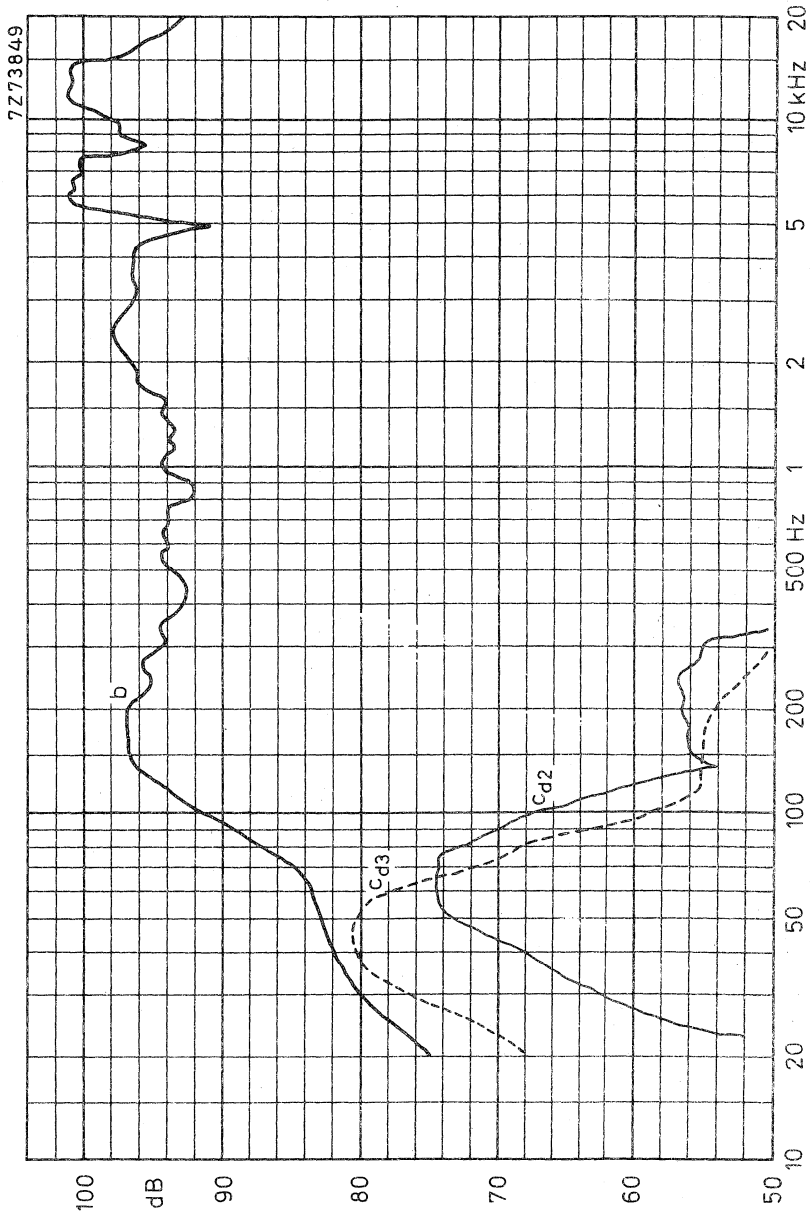

Fig. 2



DEVELOPMENT SAMPLE DATA

This information is derived from development samples made available for evaluation. It does not form part of our data handbook system and does not necessarily imply that the device will go into production

AD5081/X.**5 inch ROUND MEDIUM POWER LOUDSPEAKERS****APPLICATION**

For car and domestic radios, tape recorders, portable record players and intercoms.

TECHNICAL DATA

	version				
	X4	X8	X15	X25	
Rated impedance	4	8	15	25	Ω
Voice coil resistance	3, 4	7, 1	13, 5	22, 7	Ω
Rated frequency range	60 to 14 000				Hz
Resonance frequency	140				Hz
Power handling capacity, measured without filter, loudspeaker unmounted	6				W
Operating power (sound level 90 dB, 1 m)	0, 7				W
Sweep voltage (70 to 20 000 Hz)	3, 5	4, 9	6, 7	8, 7	V
Energy in air gap	55				mJ
Flux density	1				T
Air-gap height	3				mm
Voice coil height	4, 4	3, 9	3, 2	4	mm
Core diameter	18				mm
Magnet material	Ferroxdure				
diameter	53				mm
mass	0, 1				kg
Mass of loudspeaker	0, 25				kg

The loudspeaker has a paper rim and a foam plastic surround.

Dimensions (mm)

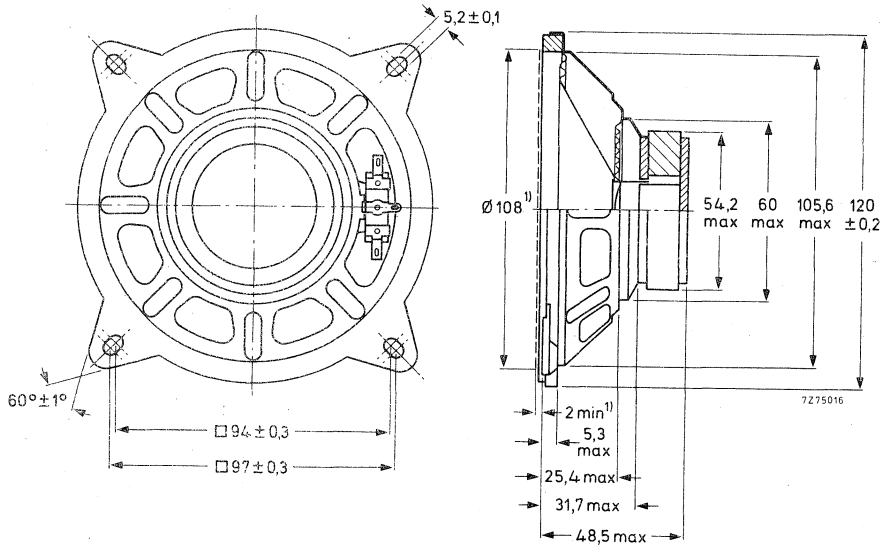

Fig.1

1) Baffle hole and clearance depth required for cone movement at the specified power handling capacity.

One tag is indicated by a red mark for in-phase connection.

AVAILABLE VERSIONS

- AD5081/X4, catalogue number 2422 257 357.1
- AD5081/X8, catalogue number 2422 257 357.2
- AD5081/X15, catalogue number 2422 257 357.3
- AD5081/X25, catalogue number 2422 257 357.4

(0 = stamped on loudspeaker magnet,
not to be used for ordering)

2 = for bulk packing *)
6 = for single unit packing

FREQUENCY RESPONSE CURVES (see Fig. 2)

Curve b: Sound pressure measured in anechoic room, loudspeaker mounted on baffle according to IEC268-5, par. 4.4.

Curve c: 2nd and 3rd harmonic distortion, measured at the operating power of 0,7 W in anechoic room. Loudspeaker front mounted on IEC baffle.

*) Minimum packing quantity 6 per unit.

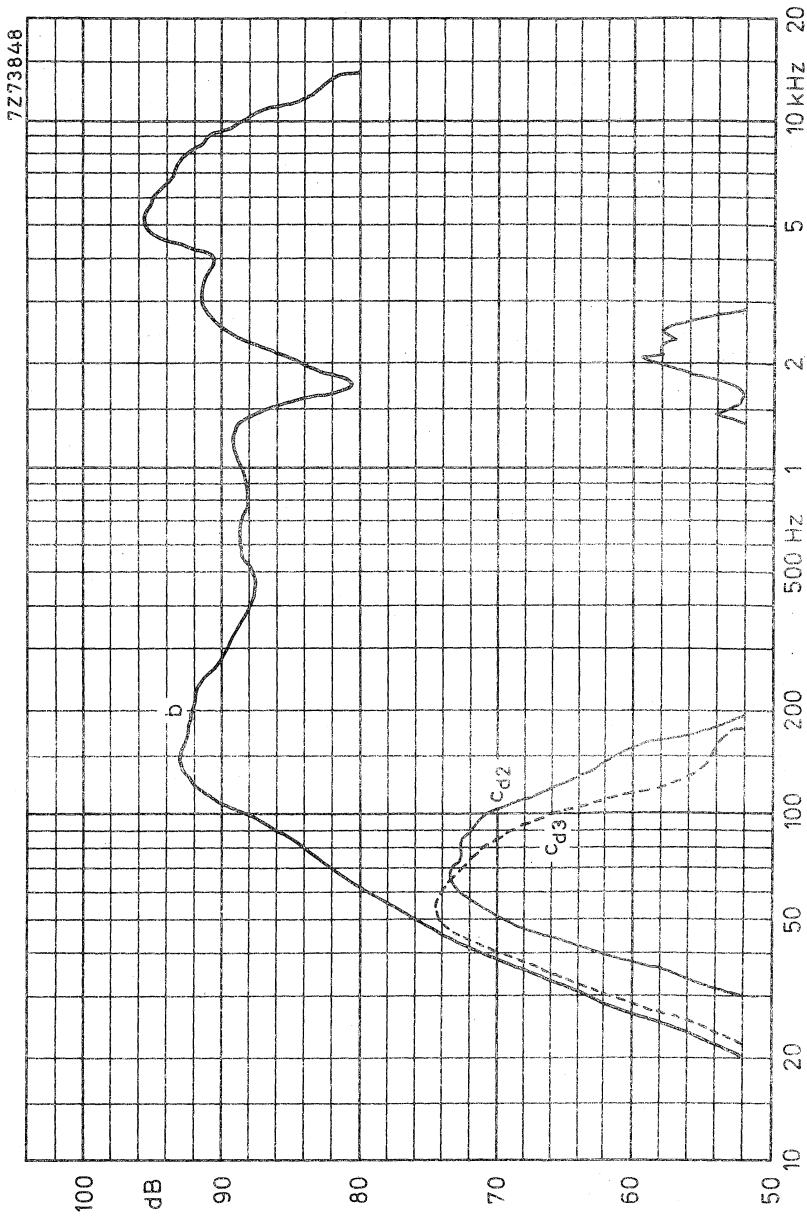

Fig. 2



5 × 7 inch OVAL MEDIUM POWER LOUDSPEAKER

APPLICATION

A full range loudspeaker for car and domestic radios, tape recorders and portable record players.

Due to its dual-cone construction, this loudspeaker has an extended frequency response up to 20 kHz.

TECHNICAL DATA

	version				
	M4	M8	M15	M25	
Rated impedance	4	8	15	25	Ω
Voice coil resistance	3,4	7,1	13,5	22,7	Ω
Resonance frequency	100	100	100	100	Hz
Power handling capacity, measured without filter loudspeaker unmounted	6	6	6	6	W
Sweep voltage	2,8	4	5,5	8,7	V
Energy in air gap	53	53	53	53	mJ
Flux density	0,98	0,98	0,98	0,98	T
Air-gap height	3	3	3	3	mm
Voice coil height	3	3,9	3,2	4	mm
Core diameter	18	18	18	18	mm
Magnet material	FXD	FXD	FXD	FXD	
diameter	53	53	53	53	mm
mass	0,1	0,1	0,1	0,1	kg
Mass of loudspeaker	0,32	0,32	0,32	0,32	kg

The loudspeaker has a paper surround and a foam plastic gasket on the flange.

Dimensions (mm)

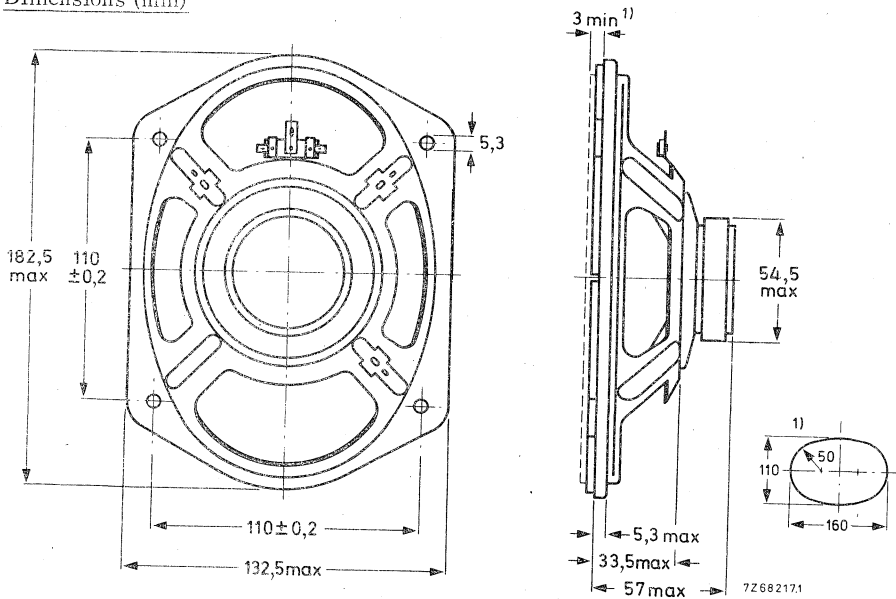

Fig. 1

1) Baffle hole and clearance depth required for cone movement at the specified power handling capacity.

One tag is indicated by a red mark for in-phase connection.

AVAILABLE VERSIONS

AD 5780/M4, catalogue number 2422 257 361.5

AD 5780/M8, catalogue number 2422 257 361.6

AD 5780/M15, catalogue number 2422 257 361.7

AD 5780/M25, catalogue number 2422 257 361.8

(0 = stamped on loudspeaker magnet,
not to be used for ordering)

—2 for bulk packing*)

—6 for single unit packing

FREQUENCY RESPONSE CURVE

Fig. 2. Input power 50 mW

Sound pressure measured in anechoic room, loudspeaker unmounted.

Above 1000 Hz the sensitivity may be, over the width of one octave, maximum 2 dB lower than indicated.

*) Minimum packing quantity 4 per unit.

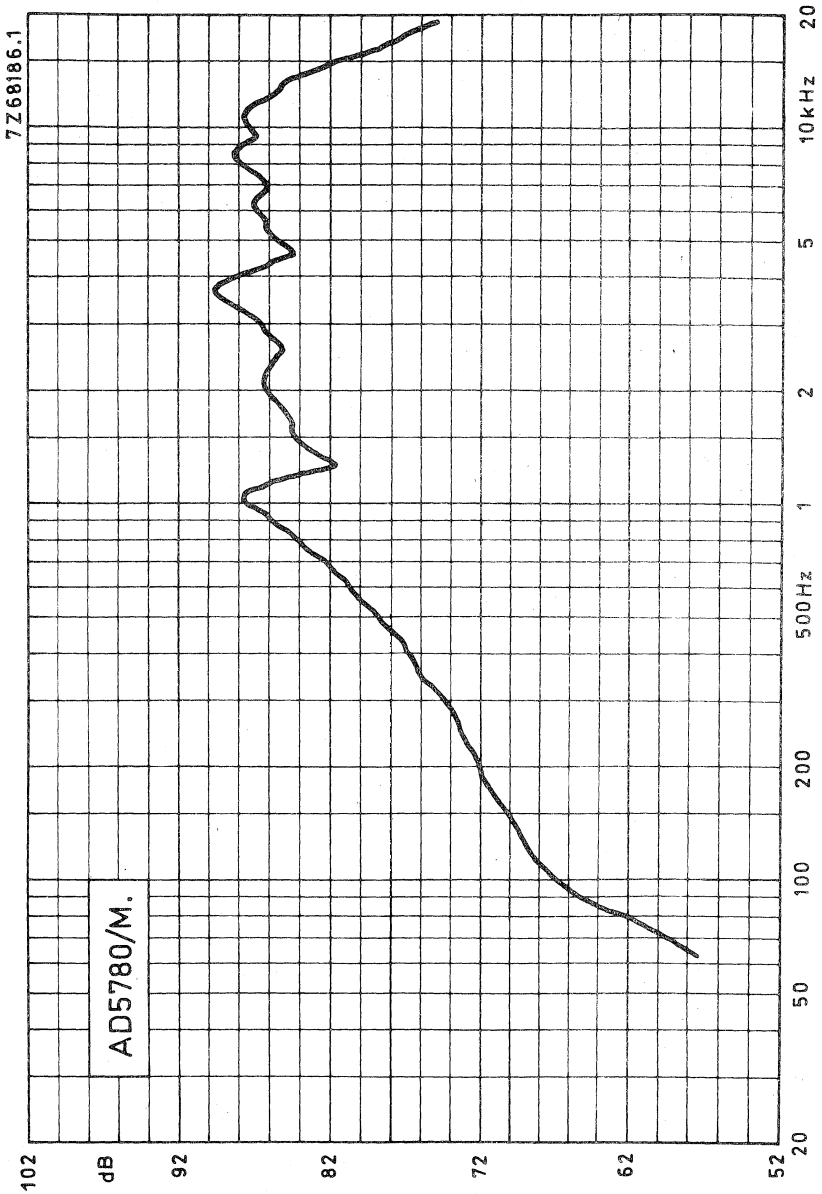

Fig. 2



5 × 7 inch OVAL MEDIUM POWER LOUDSPEAKER

APPLICATION

For car and domestic radios, tape recorders and portable record players.
High sensitivity at 4000 Hz. Frequency range up to 10 kHz.

TECHNICAL DATA

	version				
	X4	X8	X15	X25	
Rated impedance	4	8	15	25	Ω
Voice coil resistance	3,4	7,1	13,5	22,7	Ω
Resonance frequency	115	115	115	115	Hz
Power handling capacity, measured without filter, loudspeaker unmounted	6	6	6	6	W
Sweep voltage	3,4	3,5	4,8	6,1	V
Energy in airgap	55	55	55	55	mJ
Flux density	0,98	0,98	0,98	0,98	T
Airgap height	3	3	3	3	mm
Voice coil height	3	3,9	3,2	4	mm
Core diameter	18	18	18	18	mm
Magnet material	Fxd	Fxd	Fxd	Fxd	
diameter	53	53	53	53	mm
weight	0,1	0,1	0,1	0,1	kg
Weight of loudspeaker	0,32	0,32	0,32	0,32	kg

The loudspeaker has a paper surround and a foam plastic gasket on the flange.

Dimensions (mm)

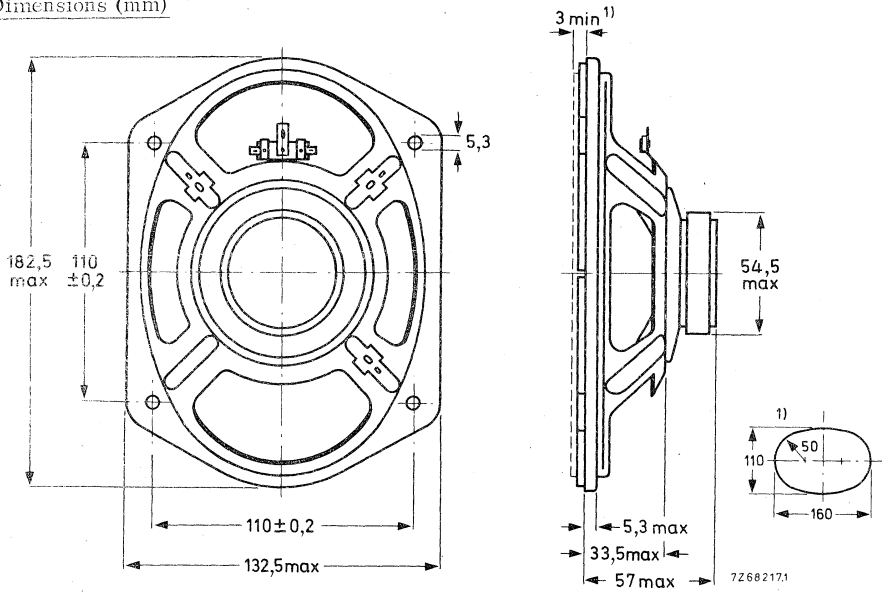

Fig. 1

1) Baffle hole and clearance depth required for cone movement at the specified power handling capacity.

One tag is indicated by a red mark for in-phase connection.

AVAILABLE VERSIONS

AD 5780/X4, catalogue number 2422 257 361.1

AD 5780/X8, catalogue number 2422 257 361.2

AD 5780/X15, catalogue number 2422 257 361.3

AD 5780/X25, catalogue number 2422 257 361.4

(0 = stamped on loudspeaker magnet,
not to be used for ordering)

— 2 for bulk packing*)
— 6 for single unit packing

FREQUENCY RESPONSE CURVE

Fig. 2. Input power 50 mW

Sound pressure measured in anechoic room, loudspeaker unmounted.

Above 1000 Hz the sensitivity may be, over the width of one octave, maximum 2 dB lower than indicated.

*) Minimum packing quantity 4 per unit.

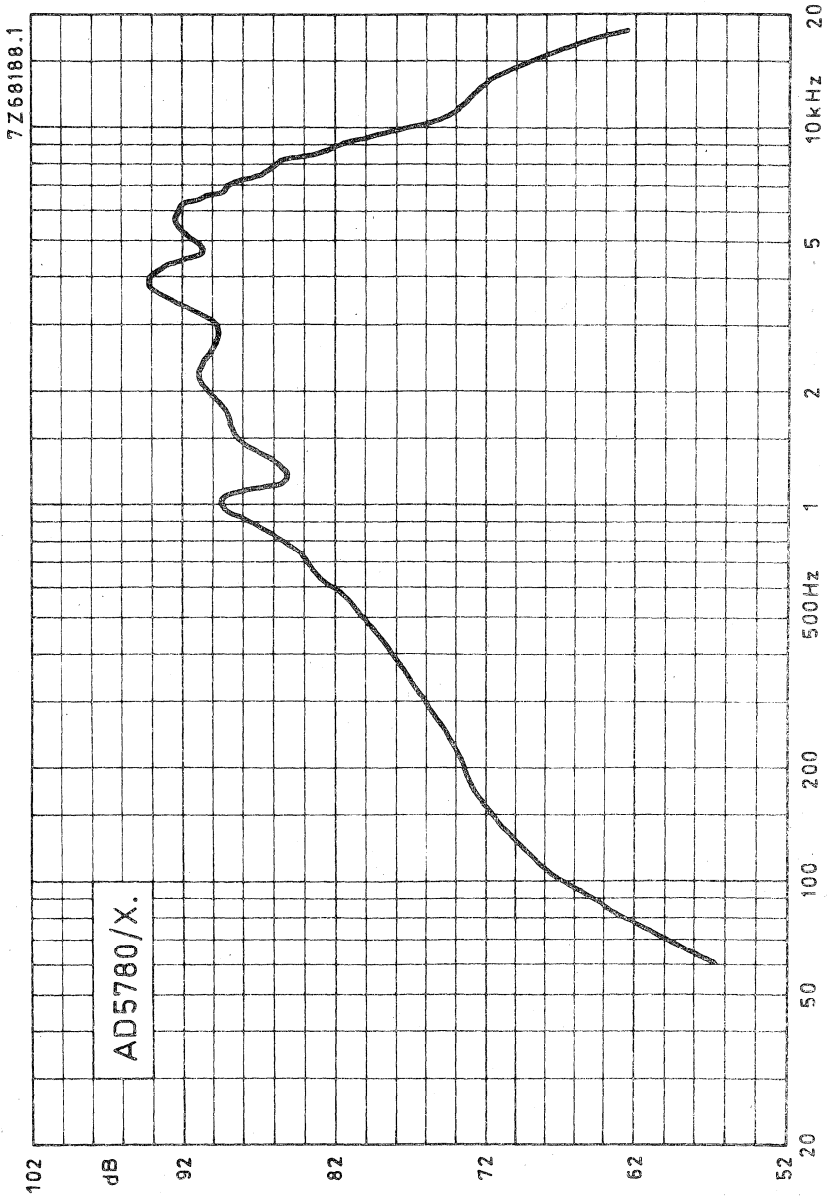

Fig.2



5 × 7 inch OVAL MEDIUM POWER LOUDSPEAKER

APPLICATION

Due to absence of stray magnetic ticonal sinterpot field, the loudspeaker can be used in black and white as well as colour television sets. High sensitivity at 3000 Hz.

TECHNICAL DATA

	version			
	M4	M8	M15	
Rated impedance	4	8	15	Ω
Voice coil resistance	3,4	7,1	13,5	Ω
Resonance frequency	100	100	100	Hz
Power handling capacity, measured without filter, loudspeaker unmounted	4	4	4	W
Sweep voltage	2,8	4	5,5	V
Energy in airgap	39	39	39	mJ
Flux density	0,8	0,8	0,8	T
Airgap height	3	3	3	mm
Voice coil height	3	3,9	3,2	mm
Core diameter	18	18	18	mm
Magnet material	Ticonal	Ticonal	Ticonal	
diameter	18	18	18	mm
weight	0,027	0,027	0,027	kg
Weight of loudspeaker	0,22	0,22	0,22	kg

The loudspeaker has a paper surround and a foam plastic gasket on the flange.

Dimensions (mm)

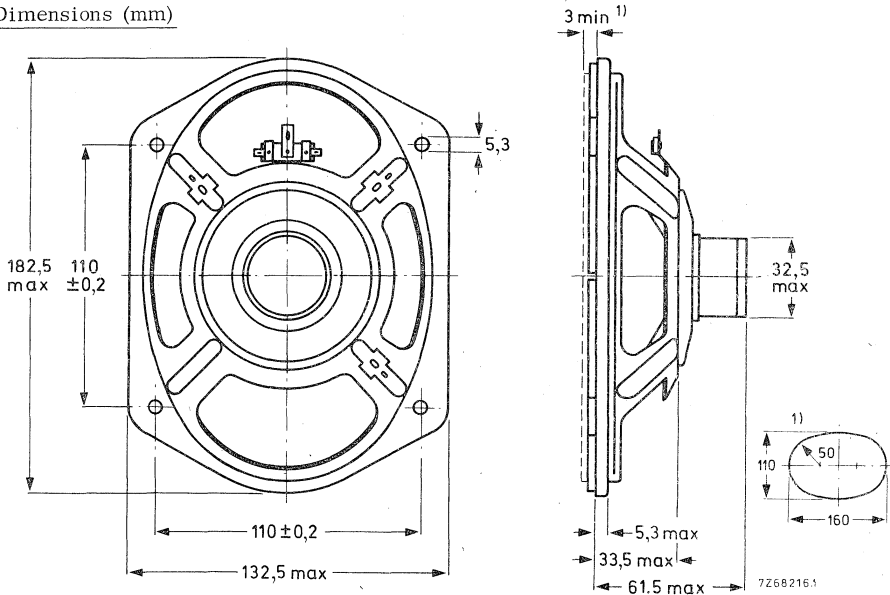

Fig. 1

¹⁾ Baffle hole and clearance depth required for cone movement at the specified power handling capacity.

One tag is indicated by a red mark for in-phase connection.

AVAILABLE VERSIONS

AD5790/M4, catalogue number 2422 256 360.1

AD5790/M8, catalogue number 2422 256 360.3

AD5790/M15, catalogue number 2422 256 360.4

(0 = stamped on the loudspeaker magnet,
Not to be used for ordering)

2 = for bulk packing *)

6 = for single unit packing

FREQUENCY RESPONSE CURVE

Fig. 2 Sound pressure measured in anechoic room, loudspeaker unmounted.

Above 1000 Hz the sensitivity may be, over the width of one octave, maximum 2 dB lower than indicated.

Input power 50 mW

*) Minimum packing quantity 4 per unit.

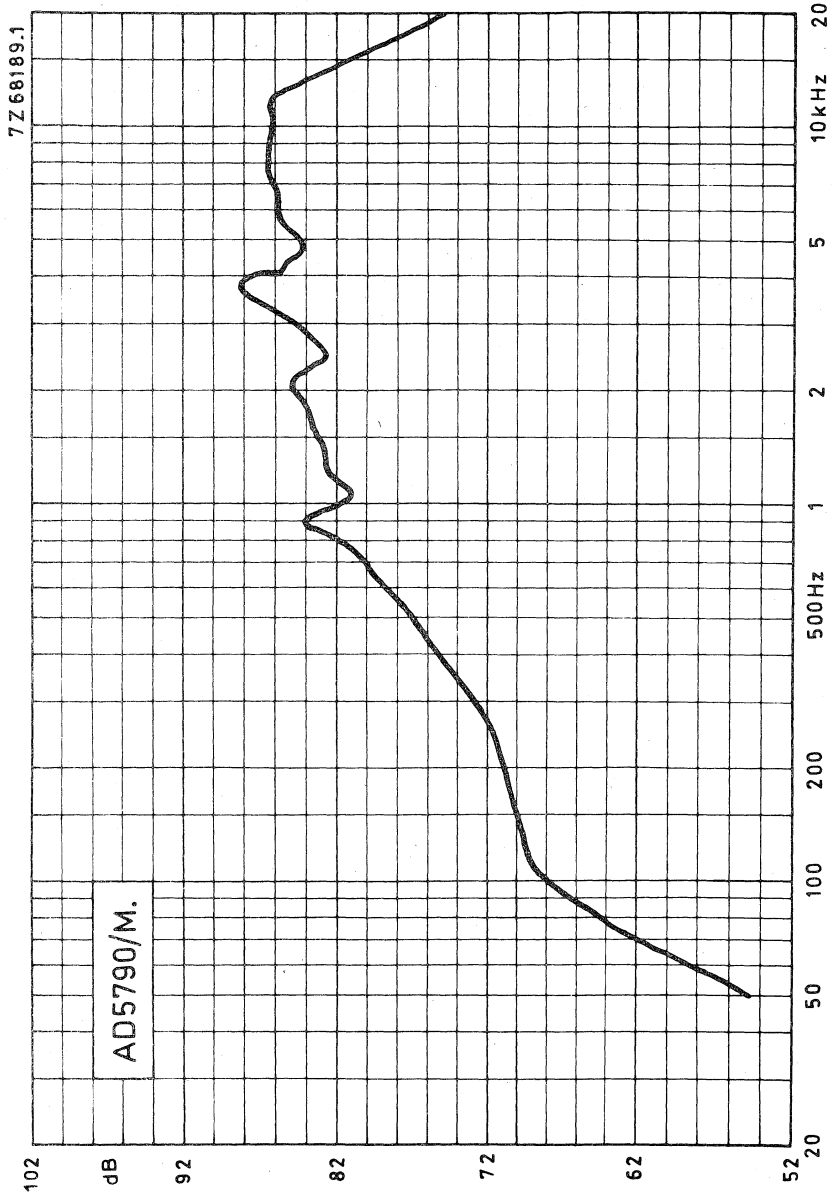

Fig. 2



5 × 7 inch OVAL MEDIUM POWER LOUDSPEAKER

APPLICATION

Due to absence of stray magnetic Ticonal sinterpot field, the loudspeaker can be used in black and white as well as colour television sets. High sensitivity at 3000 Hz.

TECHNICAL DATA

	version		
	X4	X8	
Rated impedance	4	8	Ω
Voice coil resistance	3,4	7,1	Ω
Resonance frequency	115		Hz
Power handling capacity, measured without filter, loudspeaker unmounted	4		W
Operating power	0,7		W
Sweep voltage	2,45	4	V
Energy in air gap	39		mJ
Flux density	0,8		T
Air-gap height	3		mm
Voice coil height	3	3,9	mm
Core diameter	18		mm
Magnet material	Ticonal		
diameter	18		mm
mass	0,027		kg
Mass of loudspeaker	0,22		kg

The loudspeaker has a treated paper surround and a foam plastic gasket on the flange.

Dimensions (mm)

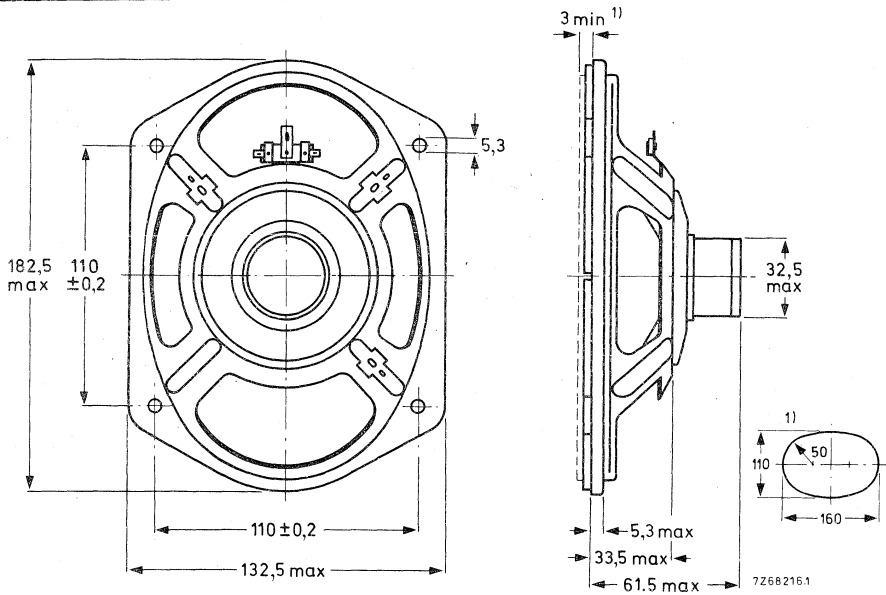

Fig. 1

¹⁾ Baffle hole and clearance depth required for cone movement at the specified power handling capacity.

One tag is indicated by a red mark for in-phase connection.

AVAILABLE VERSIONS

AD5790/X4. catalogue number 2422 256 360.2

AD5790/X8. catalogue number 2422 256 360.5

(0 = stamped on loudspeaker magnet,
not to be used for ordering)

2 for bulk packing*)

6 for single unit packing

FREQUENCY RESPONSE CURVES(see Fig. 2)

Curve b: Sound pressure measured in anechoic room at input power of 2,2 W.
Loudspeaker mounted on IEC baffle.

Curve c: 2nd and 3rd harmonic distortion, measured at input power of 2,2 W in anechoic room. Loudspeaker mounted on IEC baffle.

*) Minimum packing quantity 4 per unit.

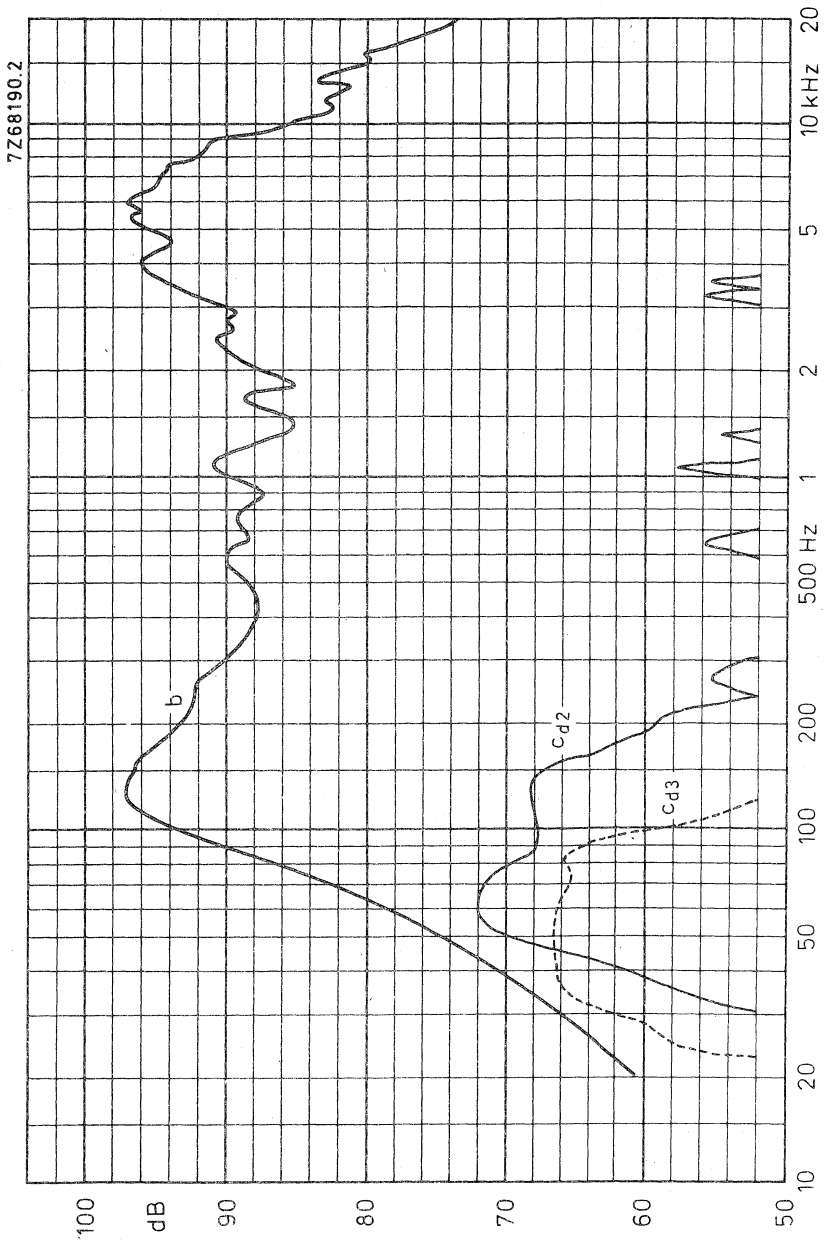

Fig.2

6 × 9 inch OVAL MEDIUM POWER LOUDSPEAKER

APPLICATION

A full range loudspeaker for car and domestic radios, tape recorders and record players. Due to its dual-cone construction, this loudspeaker has an extended frequency response up to 20 kHz.

TECHNICAL DATA

	version		
	M4	M8	
Rated impedance	4	8	Ω
Voice coil resistance	3,4	7,1	Ω
Resonance frequency	77	77	Hz
Power handling capacity, measured without filter, loudspeaker unmounted	6	6	W
Sweep voltage	3,5	4,9	V
Energy in airgap	53	53	mJ
Flux density	0,98	0,98	T
Airgap height	3	3	mm
Voice coil height	3	3,9	mm
Core diameter	18	18	mm
Magnet material	Fxd	Fxd	
diameter	53	53	mm
weight	0,1	0,1	kg
Weight of loudspeaker	0,36	0,36	kg

The loudspeaker has a paper surround and a foam plastic gasket on the flange.

Dimensions (mm)

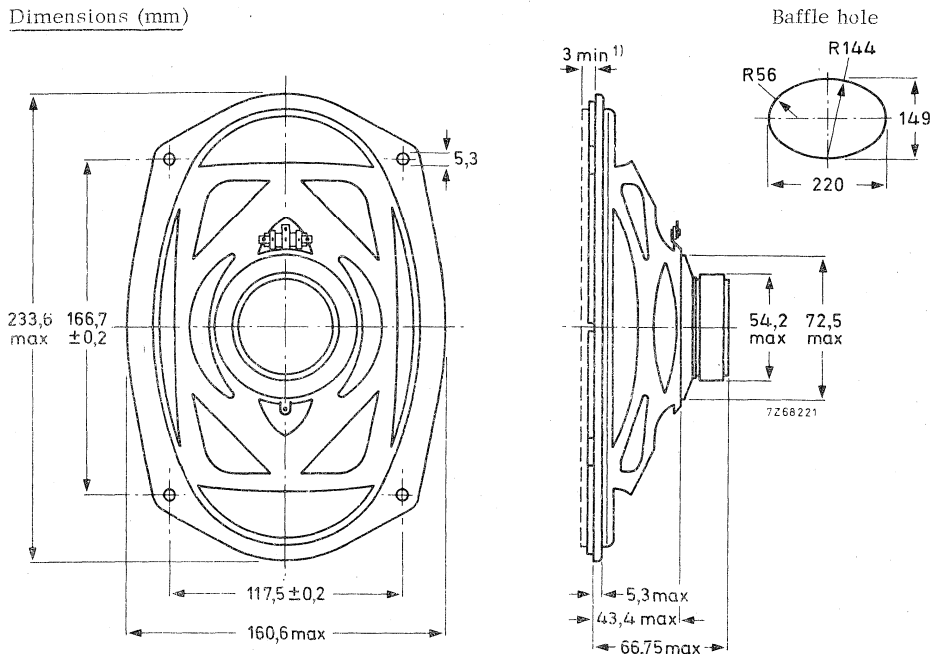

Fig. 1

1) Baffle hole and clearance depth required for cone movement at the specified power handling capacity.

One tag is indicated by a red mark for in-phase connection.

AVAILABLE VERSIONS

AD 6980/M4, catalogue number 2422 257 391.3

AD 6980/M8, catalogue number 2422 257 391.4

(0 = stamped on loudspeaker magnet
not to be used for ordering)

2 for bulk packing*)

6 for single unit packing

FREQUENCY RESPONSE CURVE

Fig. 2. Input power 50 mW

Sound pressure measured in anechoic room, loudspeaker unmounted.

Above 1000 Hz the sensitivity may be, over the width of one octave, maximum 2 dB lower than indicated.

*) Minimum packing quantity 3 per unit.

6 x 9 inch OVAL MEDIUM POWER
LOUDSPEAKER

AD6980/M.

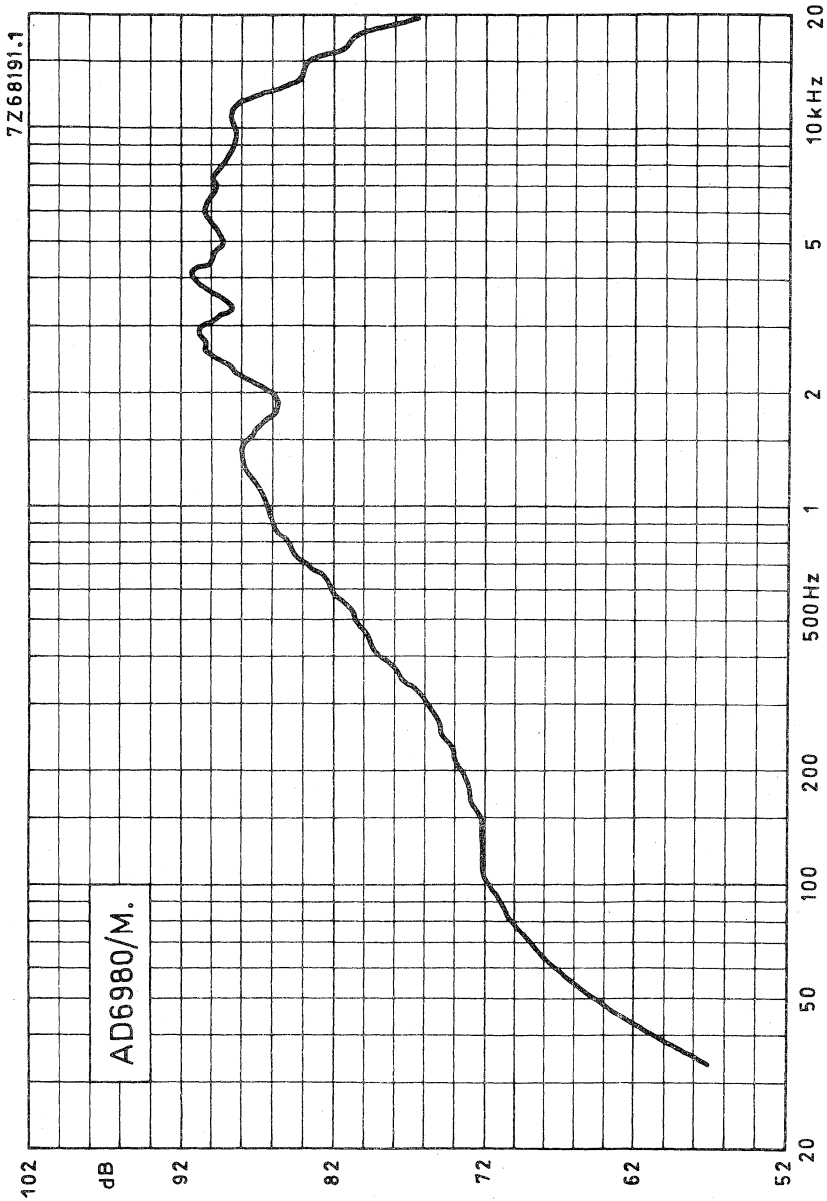

Fig. 2



6 × 9 inch OVAL MEDIUM POWER LOUDSPEAKER

APPLICATION

For car and domestic radios, tape recorders and record players. High sensitivity.

TECHNICAL DATA

	version		
	X4	X8	
Rated impedance	4	8	Ω
Voice coil resistance	3,4	7,1	Ω
Resonance frequency	90	90	Hz
Power handling capacity, measured without filter, loudspeaker unmounted	6	6	W
Sweep voltage	3,5	4,9	V
Energy in airgap	53	53	mJ
Flux density	0,98	0,98	T
Airgap height	3	3	mm
Voice coil height	3	3,9	mm
Core diameter	18	18	mm
Magnet material	Fxd	Fxd	
diameter	53	53	mm
weight	0,1	0,1	kg
Weight of loudspeaker	0,36	0,36	kg

The loudspeaker has a paper surround and a foam plastic gasket on the flange.

Dimensions (mm)

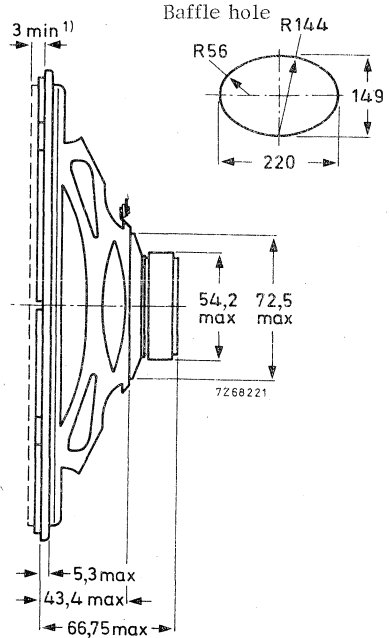
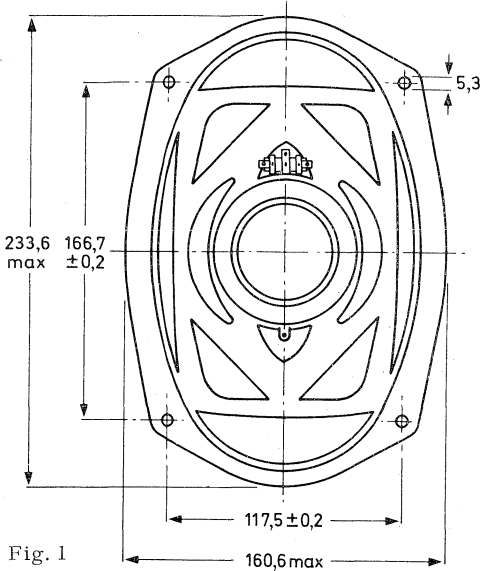

1) Baffle hole and clearance depth required for cone movement at the specified power handling capacity.

One tag is indicated by a red mark for in-phase connection.

AVAILABLE VERSIONS

Loudspeaker with foam plastic gasket on flange :

- AD 6980/X4, catalogue number 2422 257 391.1 (0 = stamped on loudspeaker magnet not to be used for ordering)
- AD 6980/X8, catalogue number 2422 257 391.2 (2 for bulk packing *) (6 for single unit packing)

FREQUENCY RESPONSE CURVE

Fig. 2. Input power 50 mW

Sound pressure measured in anechoic room, loudspeaker unmounted.

Above 1000 Hz the sensitivity may be, over the width of one octave, maximum 2 dB lower than indicated.

*) Minimum packing quantity 3 per unit.

6 x 9 inch OVAL MEDIUM POWER
LOUDSPEAKER

AD6980/X.

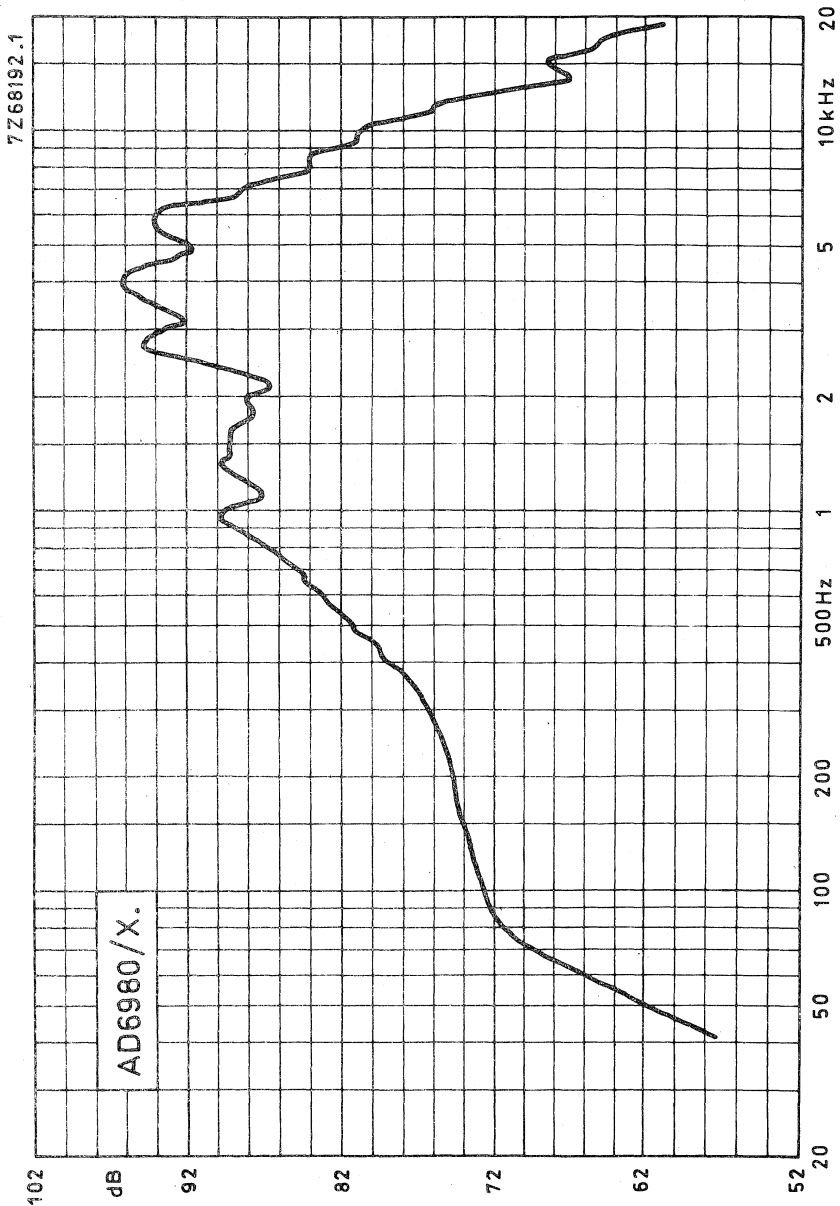

Fig. 2



7 inch HIGH POWER WOOFER LOUDSPEAKER

APPLICATION

For high fidelity reproduction in sealed acoustic enclosures.

Maximum enclosure volume 7 litres; maximum recommended cross-over frequency 3 000 Hz.

Rated frequency range 40 to 3 000 Hz.

TECHNICAL DATA

	version	
	W4	W8
Rated impedance	4	8 Ω
Voice coil resistance	4,3	8 Ω
Resonance frequency	45	45 Hz
Power handling capacity, measured without filter, mounted in 7 l sealed enclosure	30	30 W
Operating power	6,3	6,3 W
Sweep voltage frequency range 35 - 5000 Hz	3,8	5,3 V
Energy in air gap	135	140 mJ
Flux density	0,87	0,93 T
Air-gap height	5	5 mm
Voice coil height	11	11 mm
Core diameter	25	25 mm
Magnet material	FXD	FXD
diameter	72	72 mm
mass	0,26	0,26 kg
Mass of loudspeaker	0,68	0,68 kg

The loudspeaker has a rubber surround.

Connection to the loudspeaker by means of 6,3 mm (0,25 inch) Fastons or soldering.

Dimensions (mm)

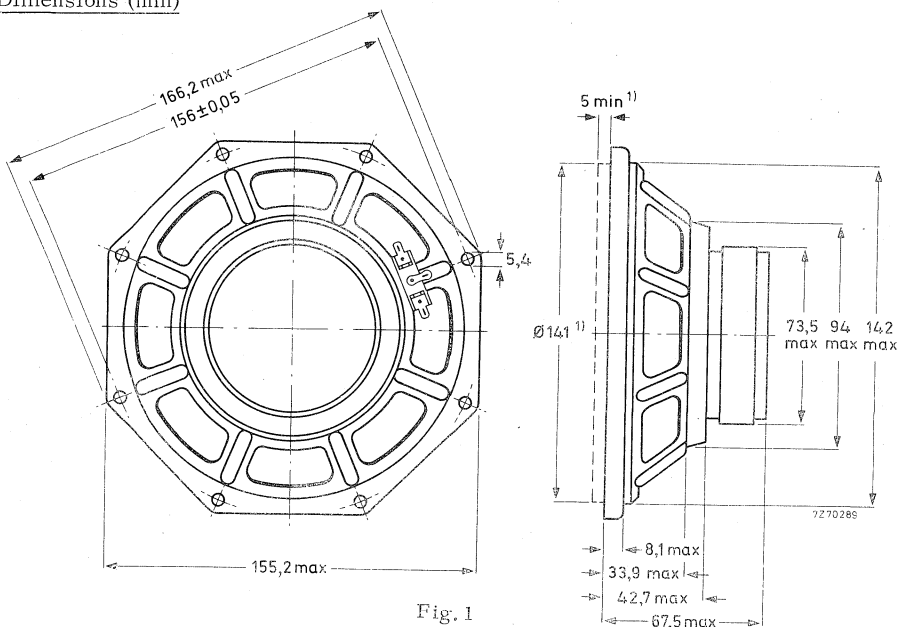

Fig. 1

1) Baffle hole and clearance depth required for cone movement at the specified power handling capacity.

One tag is indicated by a red mark for in-phase connection.

AVAILABLE VERSIONS

AD7060/W4, catalogue number 2422 257 379.1

AD7060/W8, catalogue number 2422 257 379.2

(1 = stamped on loudspeaker magnet,
not to be used for ordering)

3 = for bulk packing *)

7 = for single unit packing

FREQUENCY RESPONSE CURVES (see Fig. 2)

Curve b: Sound pressure measured in anechoic room, input at an operating power of 6,3 W. Loudspeaker mounted in sealed 80 l enclosure, filled with 1 kg of glass wool.

Curve c: 2nd and 3rd harmonic distortion, measured at the operating power of 6,3 W in anechoic room, loudspeaker mounted in sealed 80 l enclosure with 1 kg of glass wool.

*) Minimum packing quantity 4 per unit.

7 inch HIGH POWER WOOFER
LOUDSPEAKER

AD7060/W.

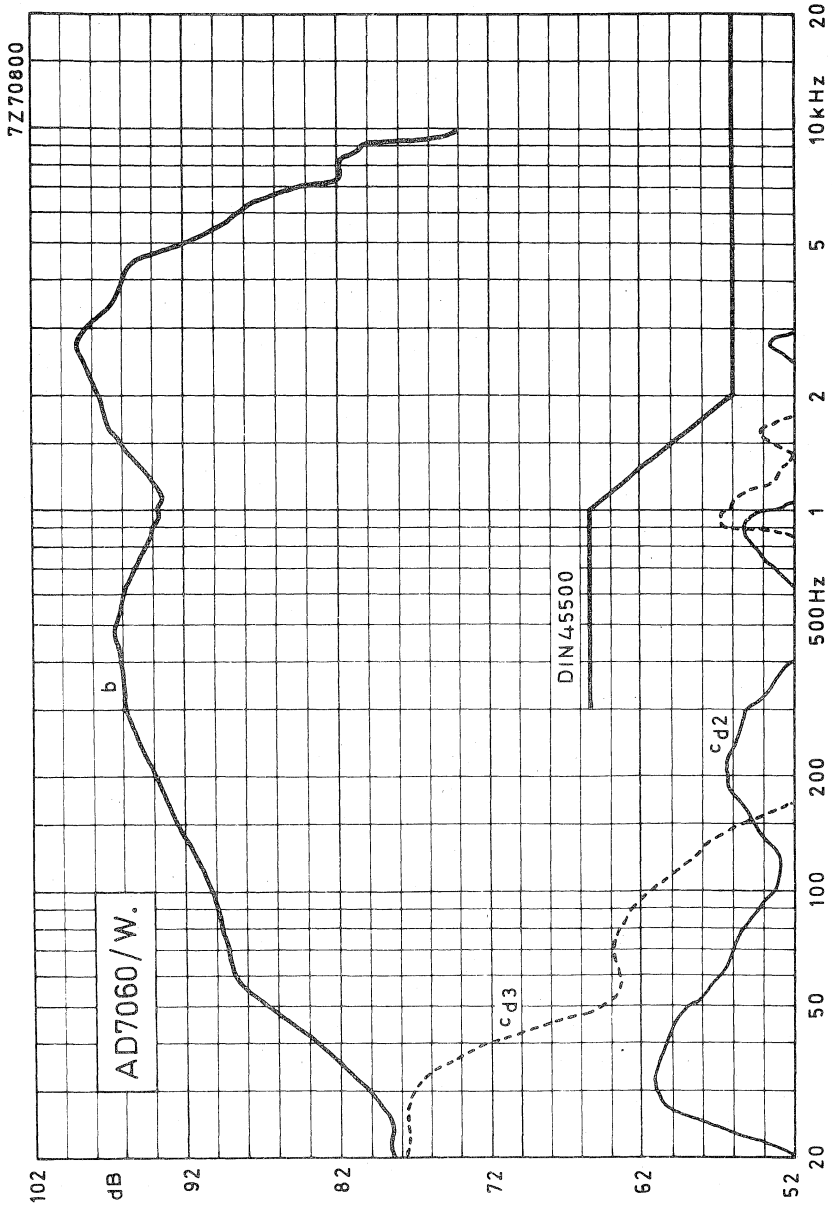

Fig. 2



7 inch HIGH POWER FULL RANGE LOUDSPEAKER

APPLICATION

For high fidelity reproduction in sealed acoustic enclosures. Maximum enclosure volume 7 litres. High power handling capacity with very low distortion.

TECHNICAL DATA

	version		
	M4	M8	
Rated impedance	4	8	Ω
Voice coil resistance	4,3	8	Ω
Resonance frequency	45	45	Hz
Power handling capacity, measured without filter, mounted in 7 l sealed enclosure	30	30	W
Operating power	5	5	W
Sweep voltage	3,8	5,3	V
Energy in air gap	135	140	mJ
Flux density	0,87	0,93	T
Air-gap height	5	5	mm
Voice coil height	11	11	mm
Core diameter	25	25	mm
Magnet material	FXD	FXD	
diameter	72	72	mm
mass	0,26	0,26	kg
Mass of loudspeaker	0,68	0,68	kg

The loudspeaker has a rubber surround and a double cone.

Connection to the loudspeaker by means of 6,3 mm (0,25 inch) Fastons or soldering.

Dimensions (mm)

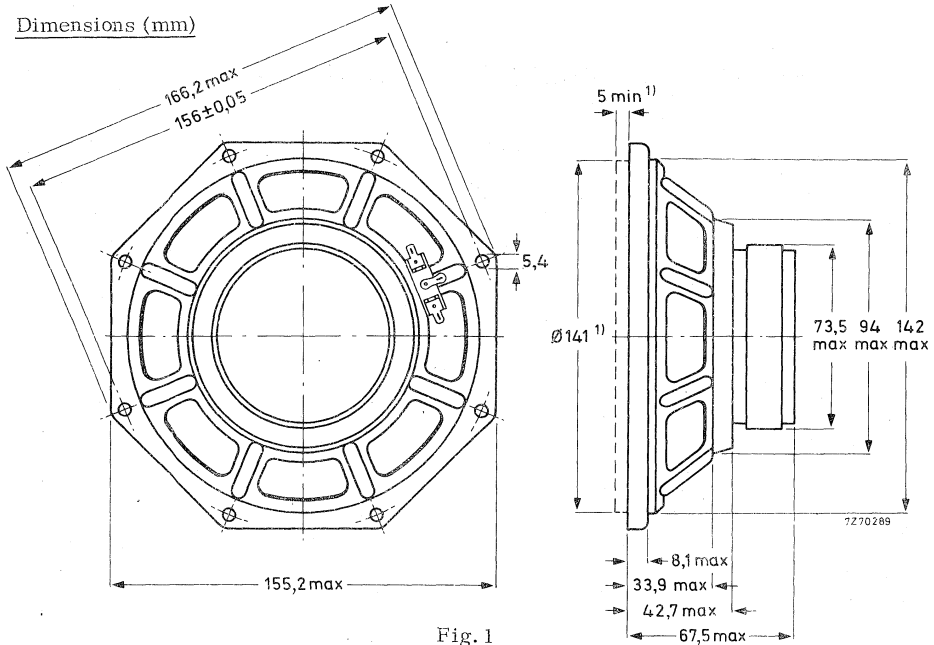

Fig. 1

1) Baffle hole and clearance depth required for cone movement at the specified power handling capacity.

One tag is indicated by a red mark for in-phase connection.

AVAILABLE VERSIONS

AD7062/M4, catalogue number 2404 257 460.1

AD7062/M8, catalogue number 2404 257 460.2

(0 = stamped on loudspeaker magnet, not to be used for ordering)

2 = for bulk packing *)

6 = for single unit packing

FREQUENCY RESPONSE CURVE

See Fig. 2

Curve b: Sound pressure measured in anechoic room at operating power. Loudspeaker mounted in sealed 80 l enclosure, filled with 1 kg of glass wool.

Curve c: 2nd and 3rd harmonic distortion, measured at the operating power of 5 W in anechoic room, loudspeaker mounted in sealed 80 l enclosure, filled with 1 kg of glass wool.

*) Minimum packing quantity 4 per unit.

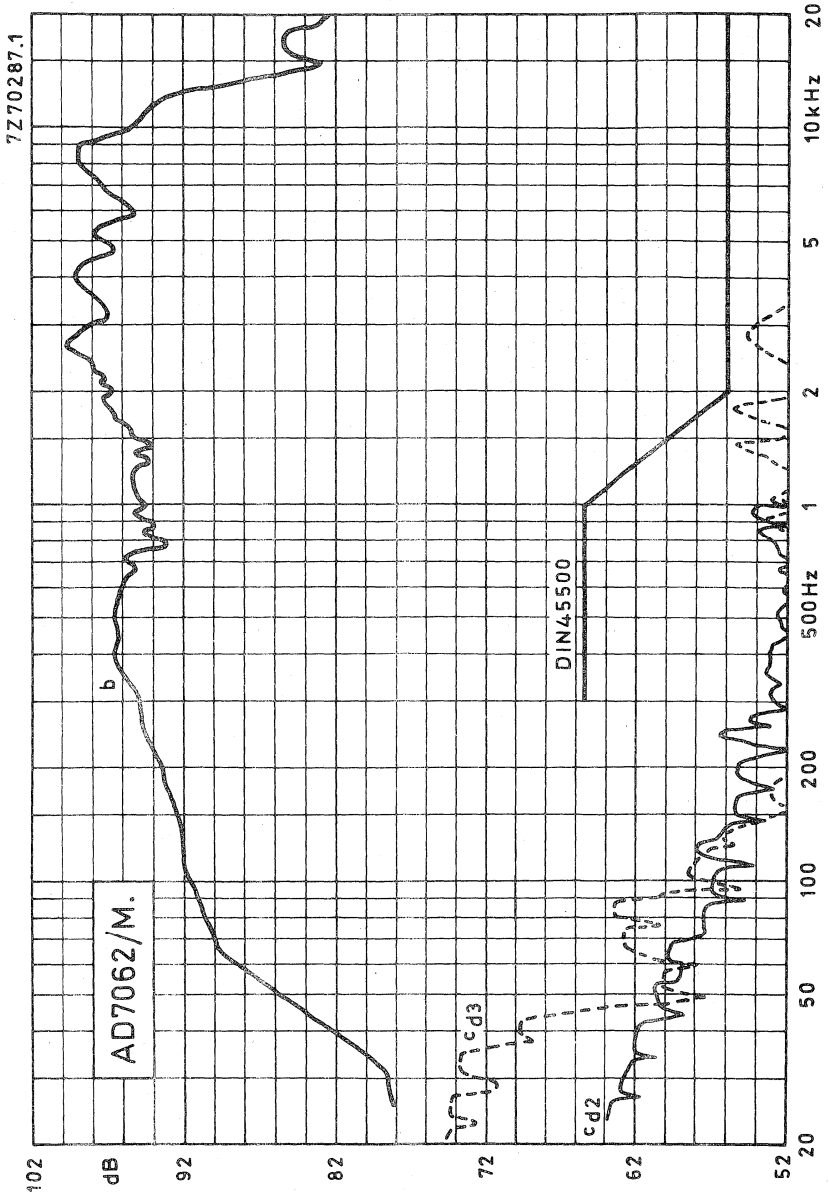

Fig. 2



7 inch HIGH POWER FULL RANGE LOUDSPEAKER

APPLICATION

For high fidelity reproduction in sealed acoustic enclosures. Maximum enclosure volume 25 litres.

Smooth response from 60 to 8000 Hz.

TECHNICAL DATA

	version		
	M4	M8	
Rated impedance	4	8	Ω
Voice coil resistance	3,4	7	Ω
Resonance frequency	55	55	Hz
Power handling capacity, measured without filter, loudspeaker unmounted	15	15	W
Operating power	2,2	2,2	W
Sweep voltage	4,5	6,3	V
Energy in air gap	127	127	mJ
Flux density	0,87	0,87	T
Air-gap height	5	5	mm
Voice coil height	6,8	6,8	mm
Core diameter	25	25	mm
Magnet material	FXD	FXD	
diameter	72	72	mm
mass	0,26	0,26	kg
Mass of loudspeaker	0,745	0,745	kg

The loudspeaker has a textile surround and a double cone.

Connection to the loudspeaker by means of 6,3 mm (0,25 inch) Fastons or soldering.

Dimensions (mm)

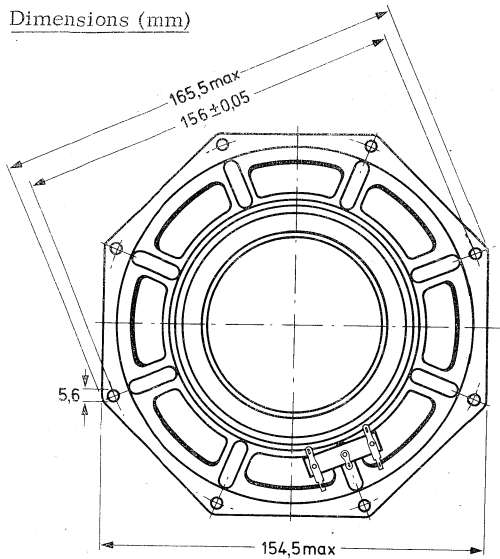
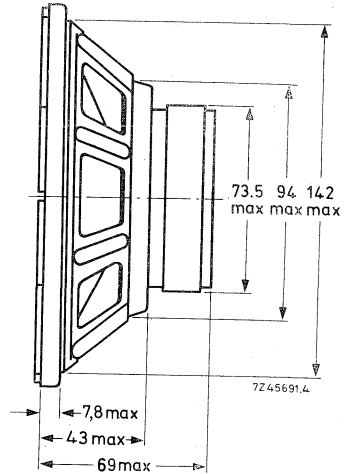

Fig. 1



Baffle hole diameter 141 mm

One tag is indicated by a red mark for in-phase connection.

AVAILABLE VERSIONS

AD7063/M4, catalogue number 2422 257 379.6

AD7063/M8, catalogue number 2422 257 379.7

(0 = stamped on loudspeaker magnet,
not to be used for ordering)

2 = for bulk packing *)

6 = for single unit packing

FREQUENCY RESPONSE CURVES (see Fig. 2)

Curve b : Sound pressure measured in anechoic room at input power of 2,2 W.
Loudspeaker mounted on IEC baffle.

Curve c : 2nd and 3rd harmonic distortion, measured at input power of 2,2 W in anechoic room. Loudspeaker mounted on IEC baffle.

*) Minimum packing quantity 4 per unit.

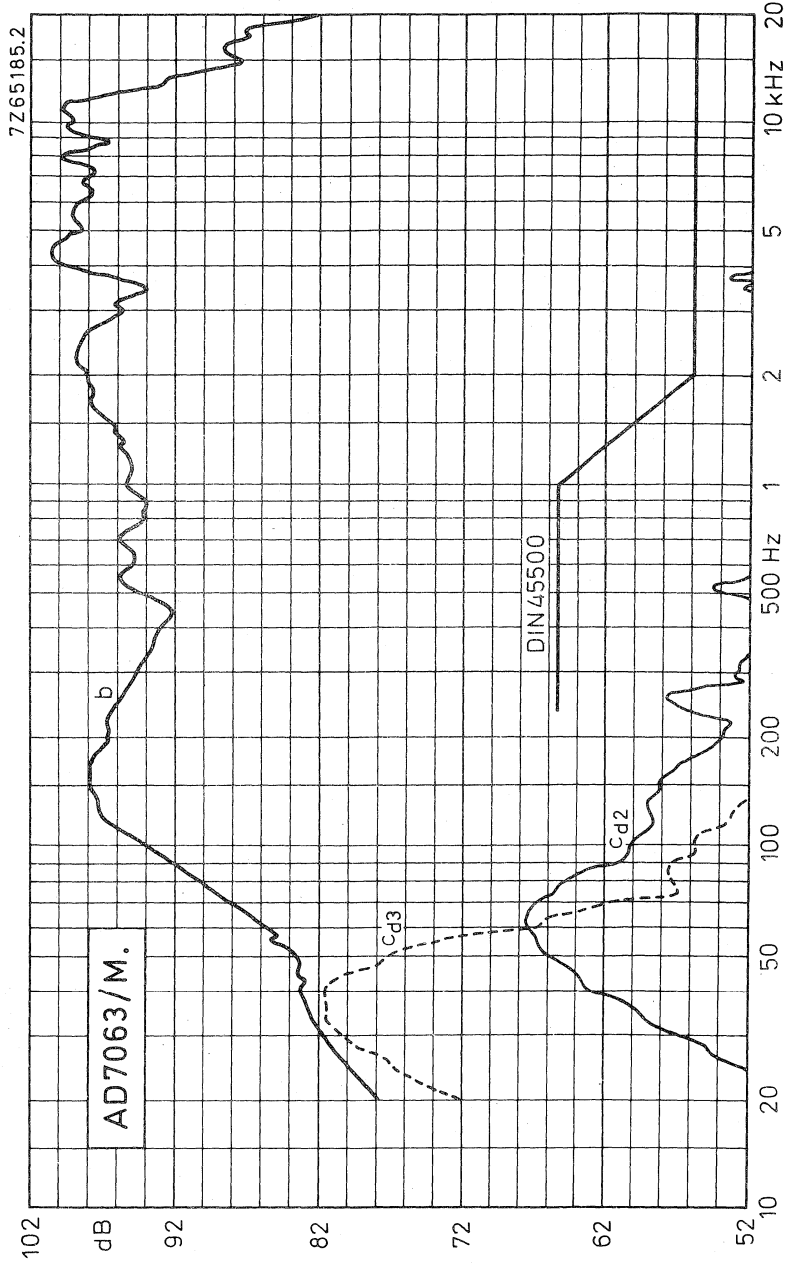

Fig. 2



7 inch HIGH POWER MOTIONAL FEEDBACK LOUDSPEAKER

APPLICATION

For application in small enclosures with very low bass response down to 40 Hz with excellent distortion suppression.

The loudspeaker has a built-in acceleration sensor.

TECHNICAL DATA

Rated impedance	4 Ω	
Voice coil resistance	4,3 Ω	
Resonance frequency	39 Hz	
Power handling capacity without filter mounted in 7 l sealed enclosure	40 W	
Operating power	7,5 W	
Sweep voltage frequency range: 35-3000 Hz	4 V	
Energy in air gap	225 mJ	
Flux density	1,1 T	
Air -gap height	5 mm	
Voice coil height	11 mm	
Core diameter	25 mm	
Magnet material	FXD	
diameter	90 mm	
mass	0,45 kg	
Mass of loudspeaker	1,15 kg	

The loudspeaker has a paper cone and rubber surround.

Connection to the loudspeaker is by means of soldering or Fastons: voice coil 6,3 mm (0,25 inch); acceleration sensor: 3,2 mm (0,12 inch).

Dimensions (mm)

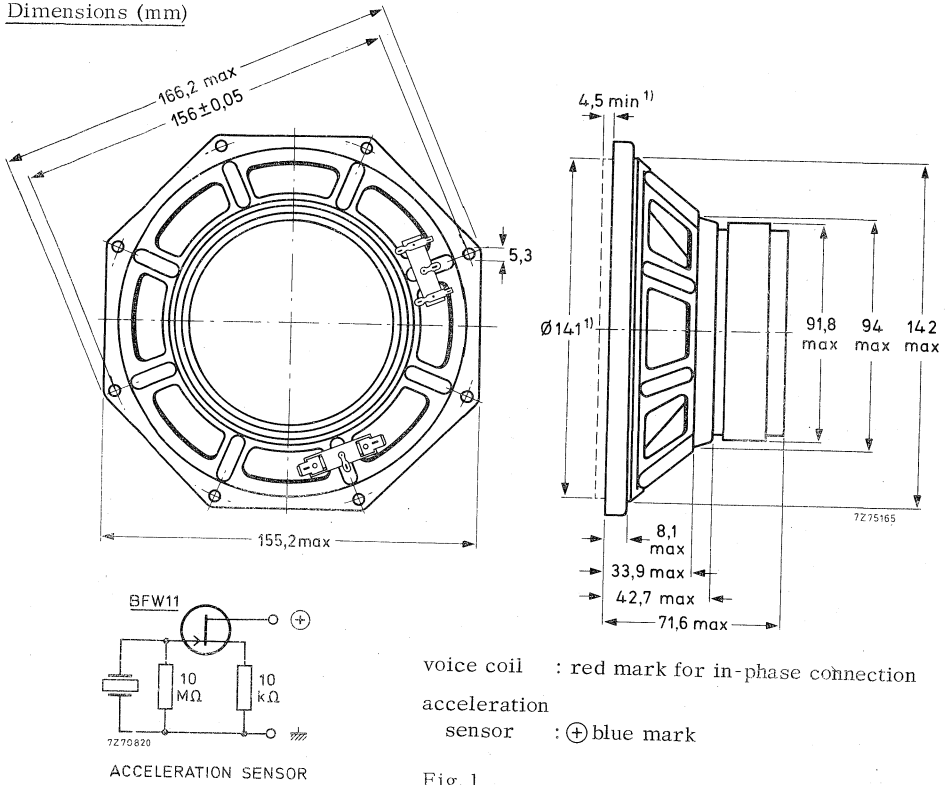

Fig. 1

1) Baffle hole and mounting clearance depth required for cone movement at the specified power handling capacity.

AVAILABLE VERSIONS

AD8067/MFB, catalogue number 2422 257 470.5

- (0 = stamped on loudspeaker magnet, not to be used for ordering)
- 2 = for bulk packing*)
- 6 = for single unit packing

FREQUENCY RESPONSE CURVES (see Fig. 2)

Curve b: Sound pressure measured in anechoic room at an operating power of 7,5 W. Loudspeaker mounted in sealed 80 l enclosure, filled with 1 kg of glass wool.

Curve c: 2nd and 3rd harmonic distortion, measured at the operating power of 7,5 W in anechoic room, loudspeaker mounted in sealed 80 l enclosure, filled with 1 kg of glass wool.

*) Minimum packing quantity 3 per unit.

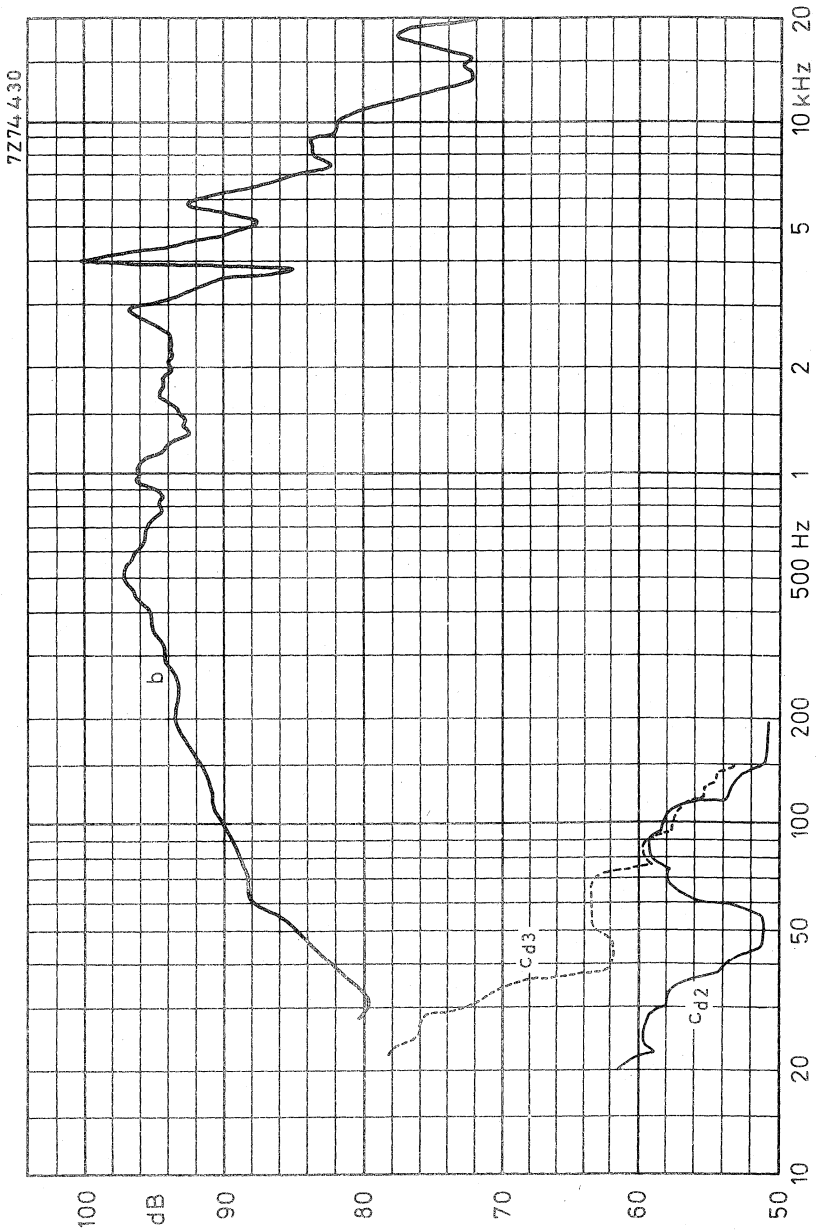

Fig. 2



COIL ACCELERATION RESPONSE CURVE (see Fig. 4)

Test conditions:

Loudspeaker unmounted.

Input at voice coil connections: 0, 44 V (50 mW/4 Ω)

Test circuit

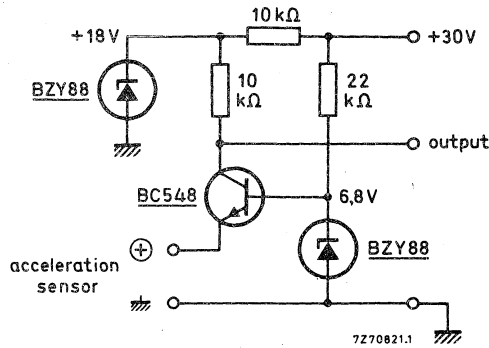

Fig. 3

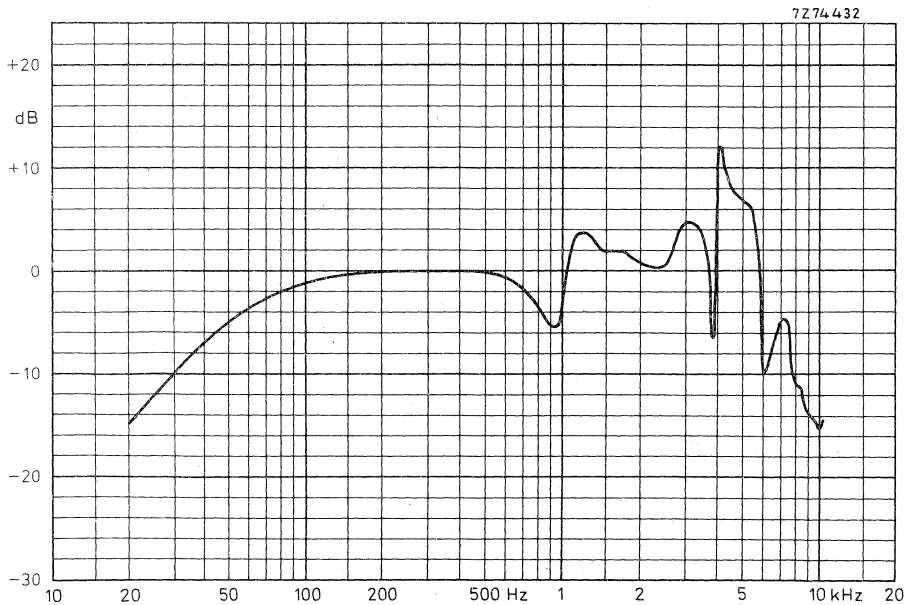

Fig. 4

Phase relation between output voltage of acceleration sensor and input voltage on voice coil

-: V_{out} lagging

+: V_{out} leading

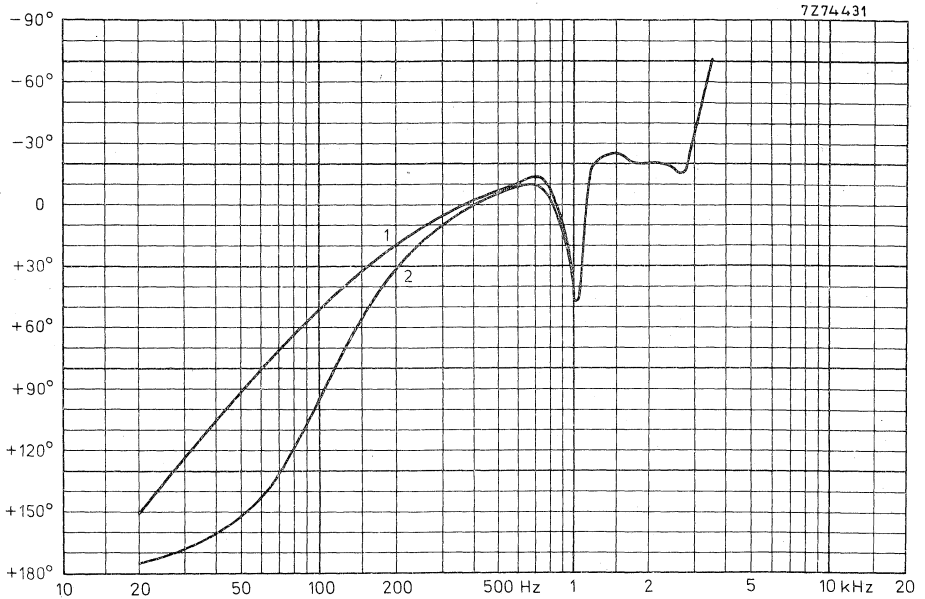

Fig. 5

Curve 1: loudspeaker unmounted; $f_{res} = 39$ Hz.

Curve 2: loudspeaker mounted in sealed 9 l enclosure; $f_{res} = 100$ Hz.

7 inch HIGH POWER WOOFER LOUDSPEAKER

APPLICATION

For high fidelity reproduction in sealed acoustic enclosures in accordance with DIN45500. Maximum enclosure volume 7 l.

Maximum recommended cross-over frequency 2000 Hz. High power handling capacity with very low distortion.

TECHNICAL DATA

	version		
	W4	W8	
Rated impedance	4	8	Ω
Voice coil resistance	4,3	8	Ω
Resonance frequency	45	45	Hz
Power handling capacity, measured without filter mounted in 7 l sealed enclosure	40	40	W
Operating power	4	4	W
Sweep voltage	3,8	5,3	V
Energy in air gap	225	207	mJ
Flux density	1,1	1,2	T
Air-gap height	5	5	mm
Voice coil height	11	11	mm
Core diameter	25	25	mm
Magnet material	FXD	FXD	
diameter	90	90	mm
mass	0,45	0,45	kg
Mass of loudspeaker	1,15	1,15	kg

The loudspeaker has a rubber surround.

Connection to the loudspeaker by means of 6,3 mm (0,25 inch) Fastons or soldering.

Dimensions (mm)

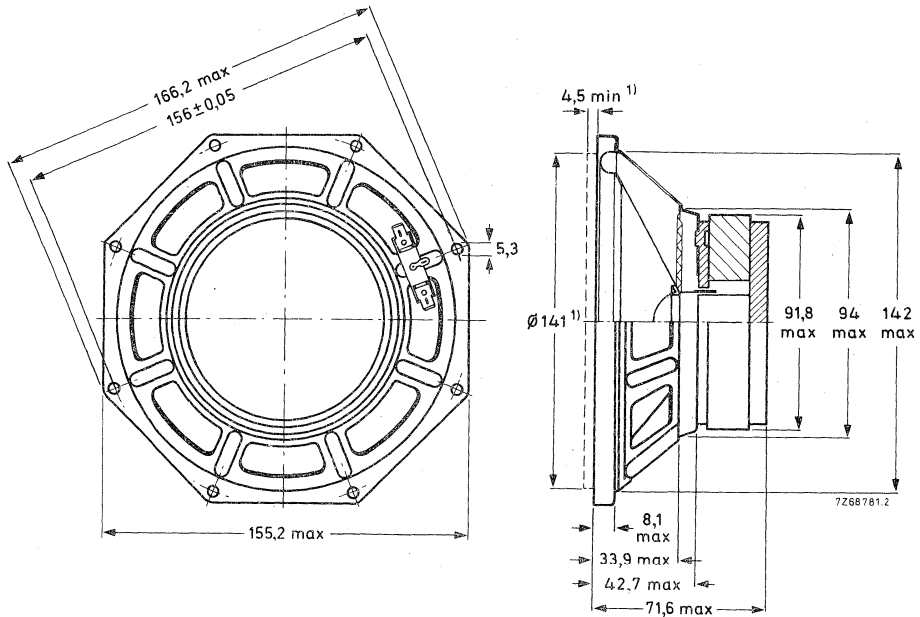

Fig.1

1) Baffle hole and clearance depth required for cone movement at the specified power handling capacity.

One tag is indicated by a red mark for in-phase connection.

AVAILABLE VERSIONS

AD7066/W4, catalogue number 2422 257 470.1

AD7066/W8, catalogue number 2422 257 470.2

(0 = stamped on loudspeaker magnet,
not to be used for ordering)

2 = for bulk packing *)

6 = for single unit packing

*) Minimum packing quantity 3 per unit.

FREQUENCY RESPONSE CURVES

Fig. 2

Curve b: Sound pressure measured in anechoic room, loudspeaker mounted in sealed 80 l enclosure, filled with 1 kg of glass wool.

Curve c: Total non-linear distortion, measured at the operating power of 4 W in anechoic room, loudspeaker mounted in sealed 80 l enclosure, filled with 1 kg of glass wool. Loudspeaker front mounted on baffle, dimensions 640 x 540 mm.



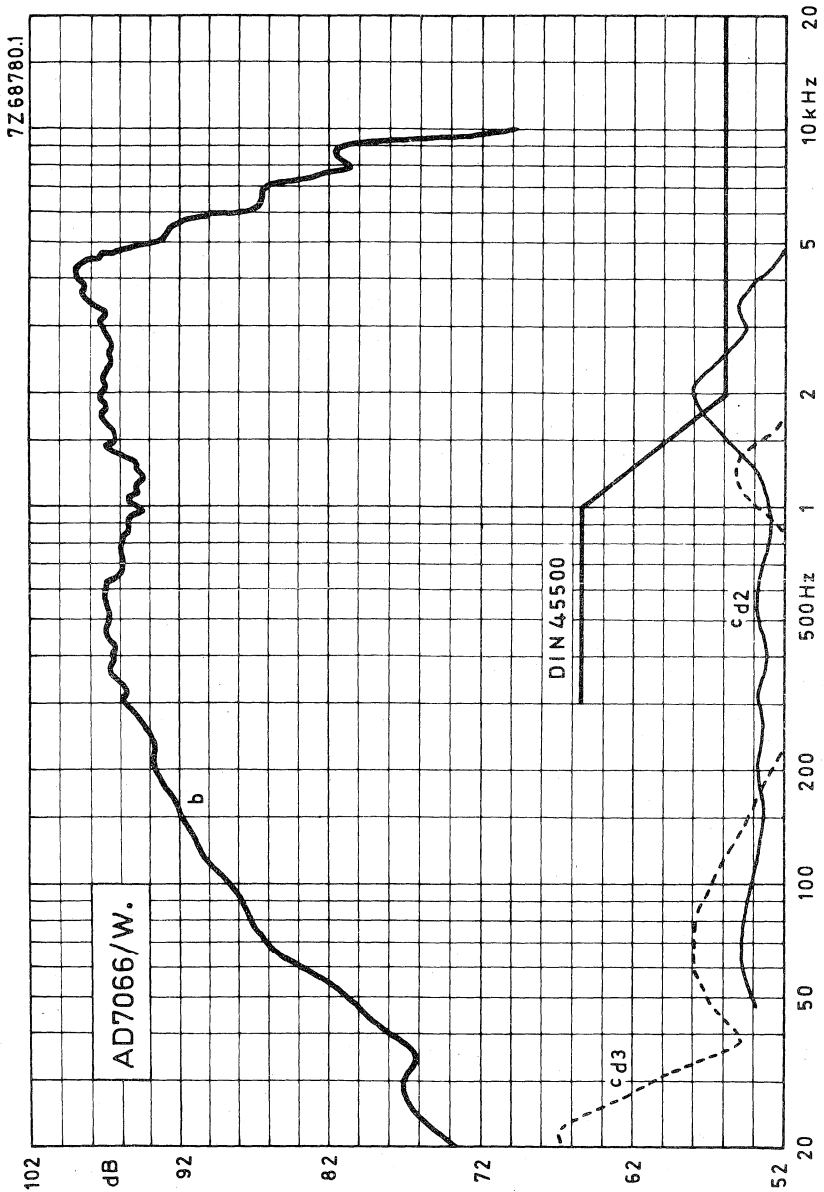

Fig.2

7 inch OCTAGONAL MEDIUM POWER LOUDSPEAKER

APPLICATION

For car and domestic radios, acoustic enclosures and public address systems.
Frequency range up to 15 kHz.

TECHNICAL DATA

	version			
	M4	M8	M15	
Rated impedance	4	8	15	Ω
Voice coil resistance	3,4	7,1	13,5	Ω
Resonance frequency	105	105	105	Hz
Power handling capacity, measured without filter loudspeaker unmounted	6	6	6	W
Sweep voltage	2,8	4	6,7	V
Energy in airgap	55	55	53	mJ
Flux density	0,98	0,98	0,98	T
Airgap height	3	3	3	mm
Voice coil height	3	3,9	3,2	mm
Core diameter	18	18	18	mm
Magnet material	Fxd	Fxd	Fxd	
diameter	53	53	53	mm
weight	0,1	0,1	0,1	kg
Weight of loudspeaker	0,29	0,29	0,29	kg

The loudspeaker has a paper surround and a foam plastic gasket on the flange.

Dimensions (mm)

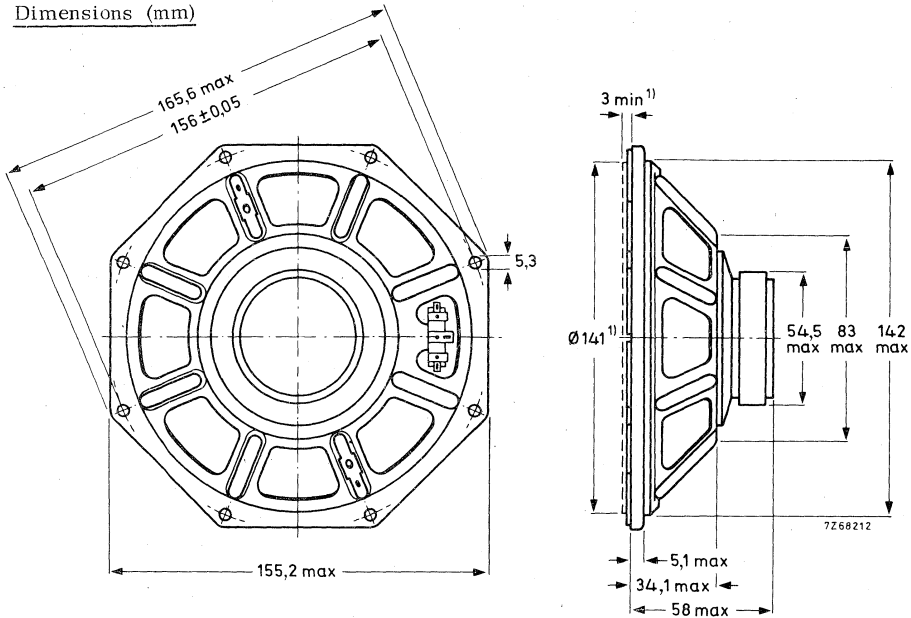

Fig. 1.

1) Baffle hole and clearance depth required for cone movement at the specified power handling capacity.

One tag is indicated by a red mark for in-phase connection.

AVAILABLE VERSIONS

AD7080/M4, catalogue number 2422 257 378.3

AD7080/M8, catalogue number 2422 257 378.4

AD7080/M15, catalogue number 2422 257 378.5

(0 = stamped on the loudspeaker magnet, not to be used for ordering)

2 = for bulk packing *)

6 = for single unit packing

FREQUENCY RESPONSE CURVE

Fig. 2. Input power 50 mW

Sound pressure measured in anechoic room, loudspeaker unmounted.

Above 1000 Hz the sensitivity may be over the width of one octave, maximum 2 dB lower than indicated.

*) Minimum packing quantity 4 per unit.

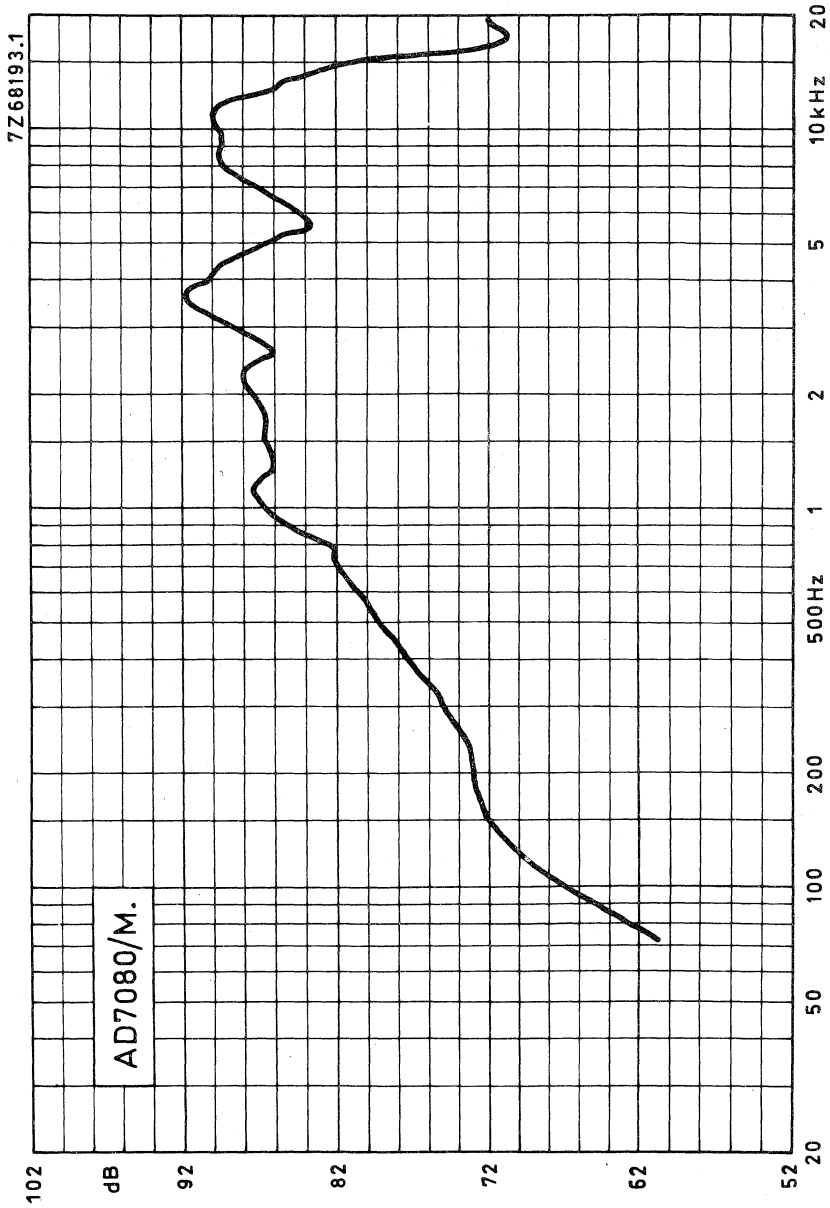

Fig. 2



7 inch OCTAGONAL MEDIUM POWER LOUDSPEAKER

APPLICATION

For car and domestic radios and accoustic enclosures.
High sensitivity at 4000 Hz.

TECHNICAL DATA

	version		
	X4	X8	
Rated impedance	4	8	Ω
Voice coil resistance	3,4	7,1	Ω
Resonance frequency	115	115	Hz
Power handling capacity, measured without filter loudspeaker unmounted	6	6	W
Sweep voltage	3,5	4,9	V
Energy airgap	55	55	mJ
Flux density	0,98	0,98	T
Airgap height	3	3	mm
Voice coil height	3	3,9	mm
Core diameter	18	18	mm
Magnet material	Fxd	Fxd	
Magnet diameter	53	53	mm
Magnet weight	0,1	0,1	kg
Weight of loudspeaker	0,29	0,29	kg

Loudspeaker has a paper surround and a foam plastic gasket on the flange.

Dimensions (mm)

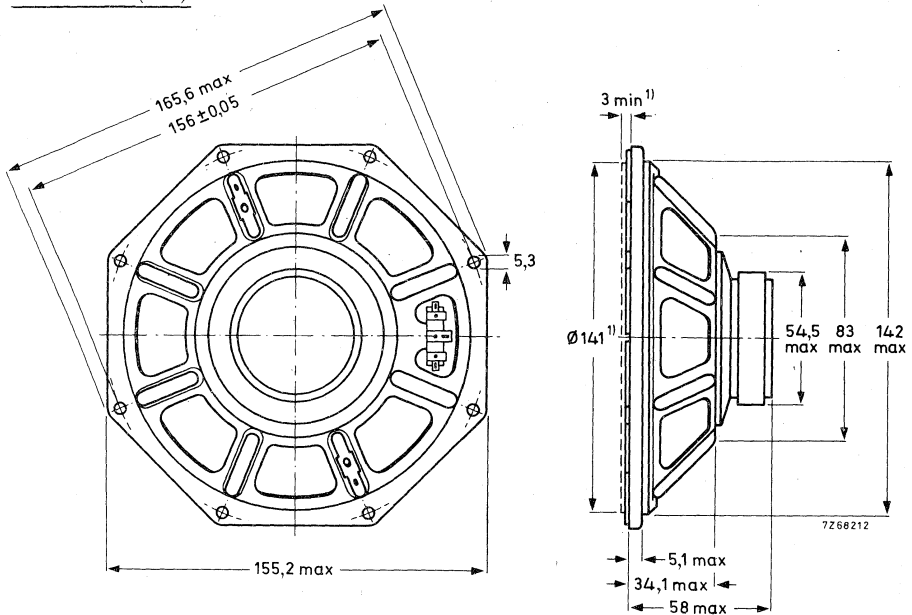

Fig. 1.

1) Baffle hole and clearance depth required for cone movement at the specified power handling capacity.

One tag is indicated by a red mark for on-phase connection.

AVAILABLE VERSIONS

AD 7080/X4, catalogue number, 2422 257 378.1

AD 7080/X8, catalogue number, 2422 257 378.2

- (0 = stamped on loudspeaker magnet, not to be used for ordering)
- 2 for bulk packing*)
- 6 for single unit packing.

FREQUENCY RESPONSE CURVE

Fig. 2. Input power 50 mW

Sound pressure measured in anechoic room, loudspeaker is unmounted.
 Above 1000 Hz the sensitivity may be, over the width of one octave, maximum 2 dB lower than indicated.

*) Minimum packing quantity 4 per unit.

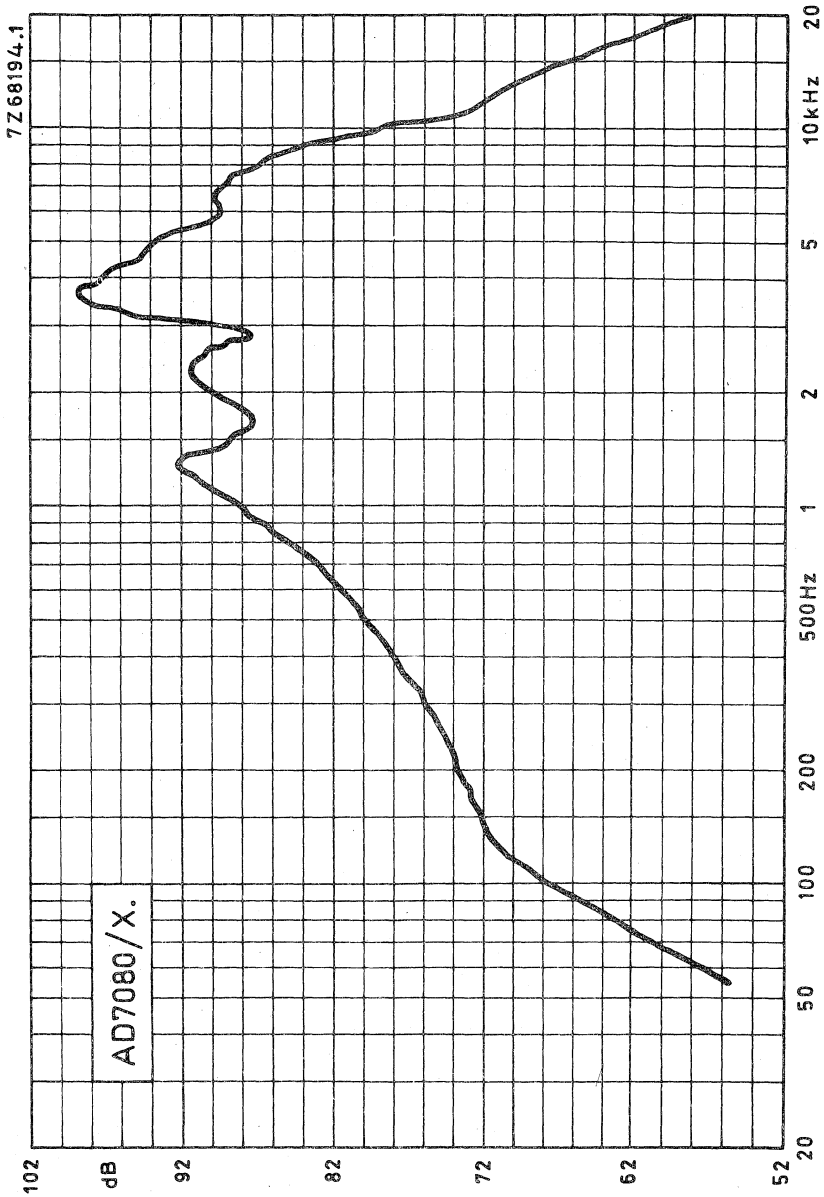

Fig.2



7 inch ROUND MEDIUM POWER LOUDSPEAKER

APPLICATION

For television sets and record players.

TECHNICAL DATA

	version				
	M4	M8	M400	M800	
Rated impedance	4	8	400	800	Ω
Voice coil resistance	3,4	7,1	330	600	Ω
Resonance frequency	105	105	105	105	Hz
Power handling capacity, measured without filter loudspeaker unmounted	3	3	3	3	W
Sweep voltage	2,45	3,5	24,5	34,5	V
Energy in airgap	39	39	39	39	mJ
Flux density	0,8	0,8	0,8	0,8	T
Airgap height	3	3	3	3	mm
Voice coil height	2,4	3,1	4	4,65	mm
Core diameter	18	18	18	18	mm
Magnet material	Ticonal	Ticonal	Ticonal	Ticonal	
diameter	18	18	18	18	mm
weight	0,027	0,027	0,027	0,027	kg
Weight of loudspeaker	0,22	0,22	0,22	0,22	kg

The loudspeaker has a paper surround and a foam plastic gasket on the flange.

Dimensions (mm)

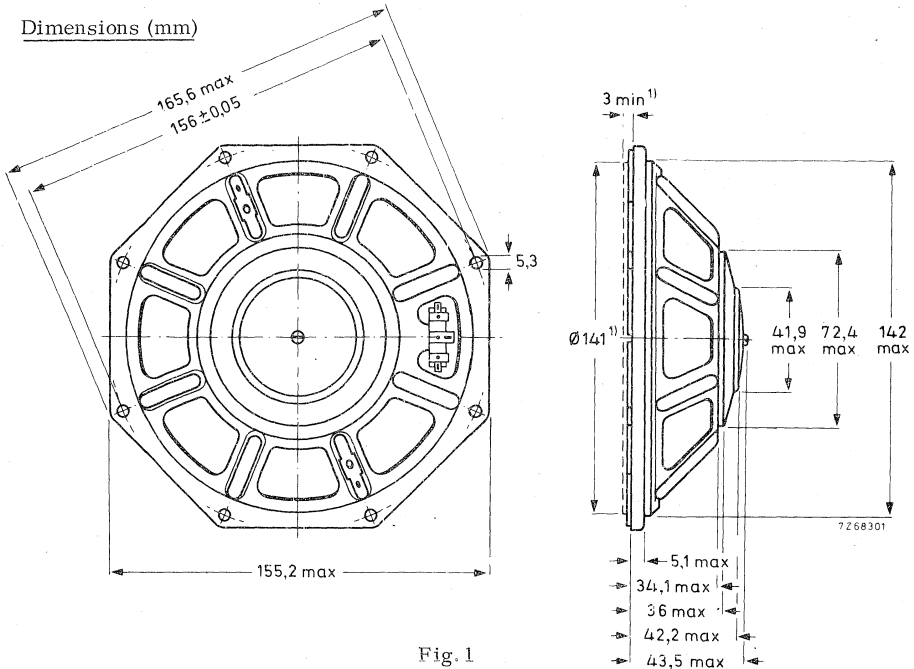

Fig. 1

1) Baffle hole and clearance depth required for cone movement at the specified power handling capacity.

One tag is indicated by a red mark for in-phase connection.

AVAILABLE VERSIONS

AD7091/M4 , catalogue number 2422 256 370. 4

AD7091/M8 , catalogue number 2422 256 370. 9

AD7091/M400, catalogue number 2422 256 370. 3

AD7091/M800, catalogue number 2422 256 370. 1

(0 = stamped on loudspeaker magnet
not to be used for ordering)

2 = for bulk packing *)

6 = for single unit packing

FREQUENCY RESPONSE CURVE

Fig. 2 Input power 50 mW

Sound pressure measured in anechoic room, loudspeaker unmounted.

Above 1000 Hz the sound pressure may be, over the width of one octave, maximum 2 dB lower than indicated.

*) Minimum packing quantity 4 per unit.

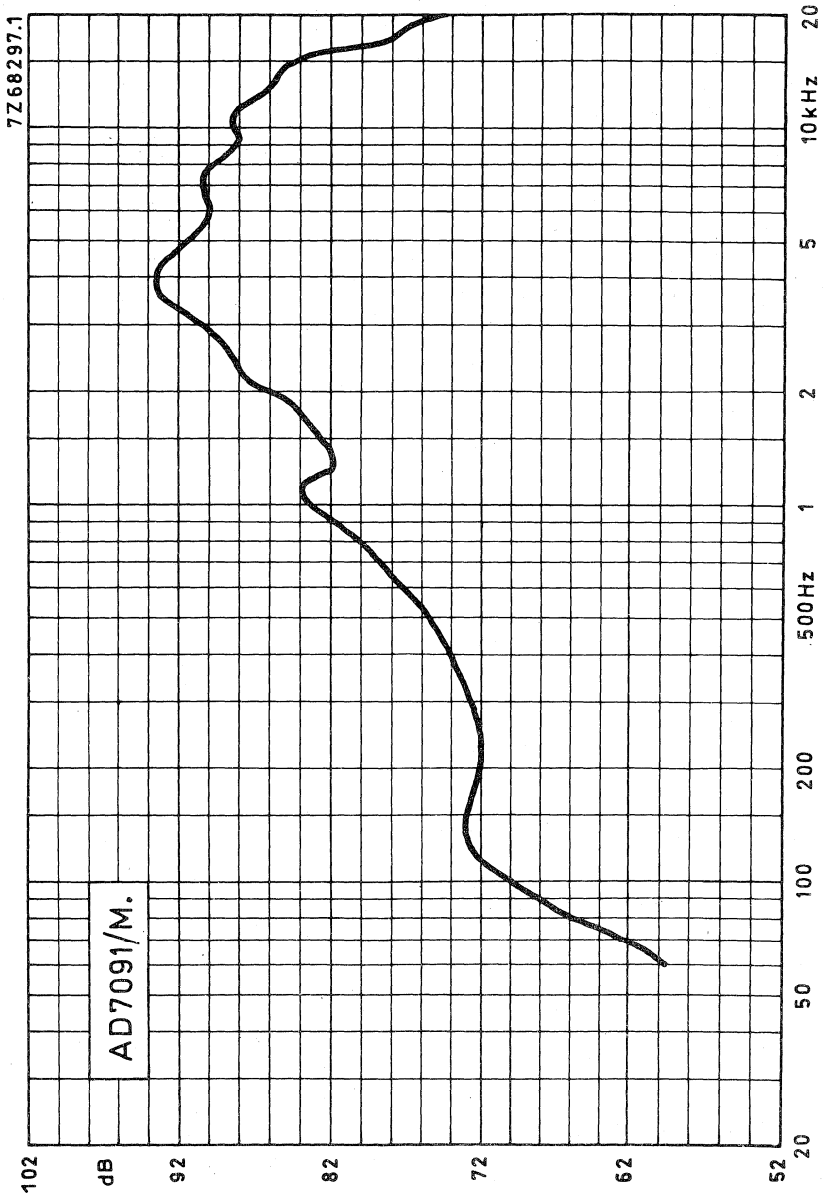

Fig. 2



7 inch ROUND MEDIUM POWER LOUDSPEAKER

APPLICATION

For television sets and record players.

TECHNICAL DATA

	version			
	X4	X8	X800	
Rated impedance	4	8	800	Ω
Voice coil resistance	3,4	7,1	600	Ω
Resonance frequency	115	115	115	Hz
Power handling capacity, measured without filter loudspeaker unmounted	3	3	3	W
Sweep voltage	2,45	3,5	34,5	V
Energy in airgap	39	39	39	mJ
Flux density	0,8	0,8	0,8	T
Airgap height	3	3	3	mm
Voice coil height	2,4	3,1	4,65	mm
Core diameter	18	18	18	mm
Magnet material	Ticonal	Ticonal	Ticonal	
diameter	18	18	18	mm
weight	0,027	0,027	0,027	kg
Weight of loudspeaker	0,22	0,22	0,22	kg

The loudspeaker has a paper surround and a foam plastic gasket on the flange.

Dimensions (mm)

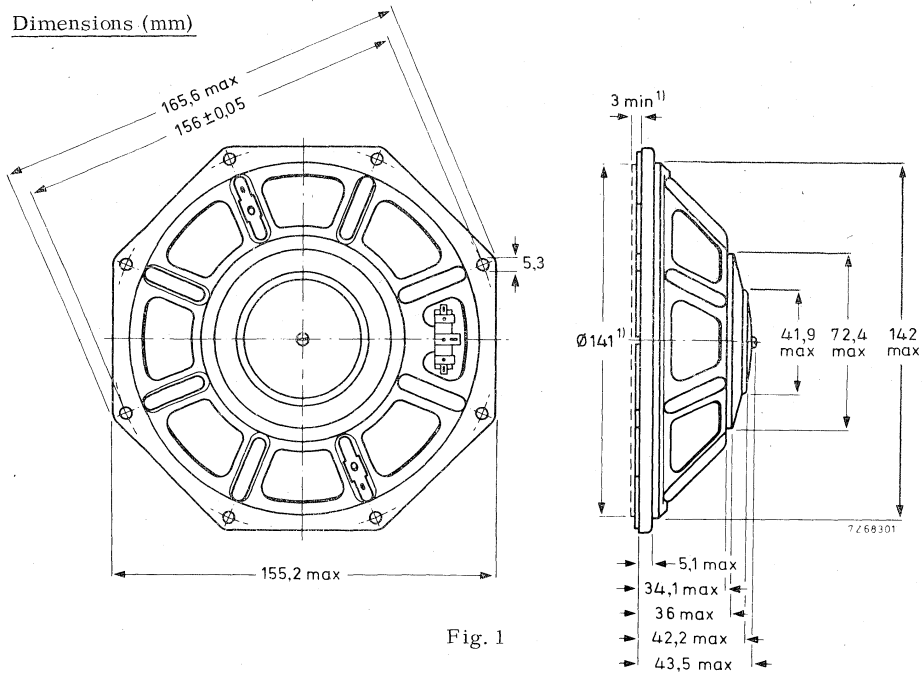

Fig. 1

1) Baffle hole and clearance depth required for cone movement at the specified power handling capacity.

One tag is indicated by a red mark for in-phase connection.

AVAILABLE VERSIONS

AD7091/X4 , catalogue number 2422 256 370.5

AD7091/X8 , catalogue number 2422 256 370.8

AD7091/X800, catalogue number 2422 256 370.2

(0 = stamped on loudspeaker magnet
not to be used for ordering)

2 = for bulk packing *)

6 = for single unit packing

FREQUENCY RESPONSE CURVE

Fig. 2 Input power 50 mW

Sound pressure measured in anechoic room, loudspeaker unmounted.

Above 1000 Hz the sound pressure may be, over the width of one octave, maximum 2 dB lower than indicated.

*) Minimum packing quantity 4 per unit.

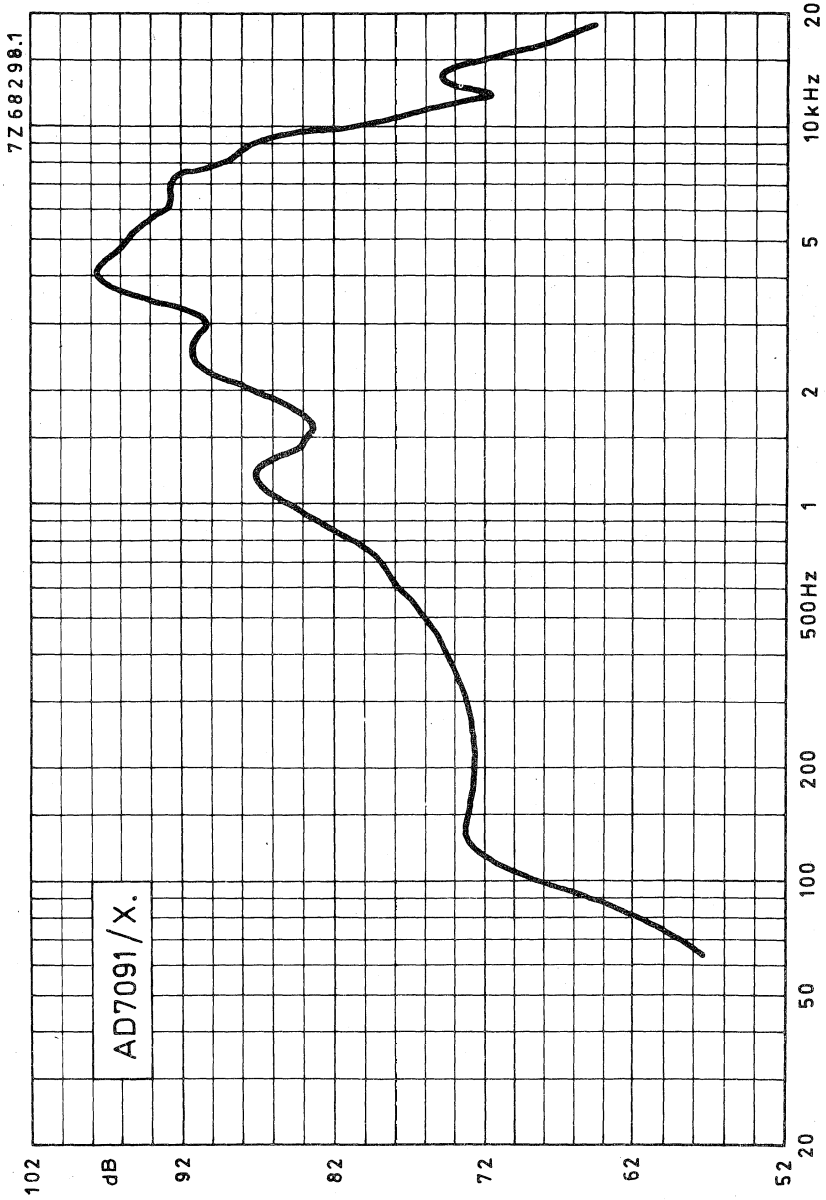

Fig. 2



8 inch PASSIVE RADIATOR

APPLICATION

To be used in combination with loudspeaker AD8066/W. in a sealed 35 l enclosure for an improved bass response.

TECHNICAL DATA

Effective area	$2,5 \times 10^{-2} \text{ m}^2$	
Moving mass:		
tuned mass	21,5	g
cone mass	9,8	g
total moving mass	31,3	g
Mass of radiator	0,235	kg

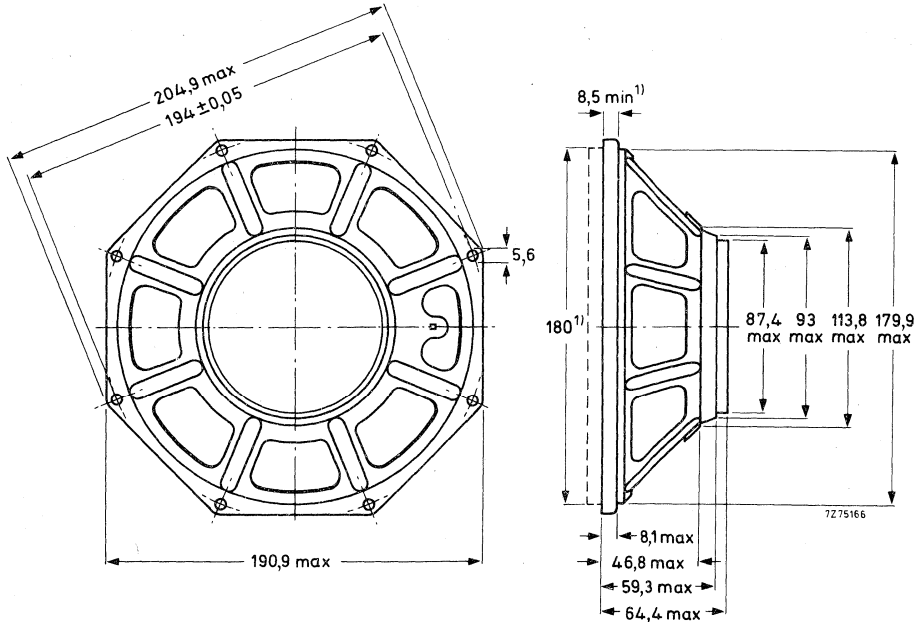

¹⁾ Baffle hole and clearance depth required for cone movement.

8 inch HIGH POWER WOOFER LOUDSPEAKER

APPLICATION

For high fidelity reproduction in sealed acoustic enclosures. Maximum enclosure volume 25 litres. Maximum recommended cross-over frequency 2000 Hz.
Rated frequency range 30 to 5 000 Hz.

TECHNICAL DATA

	version		
	W4	W8	
Rated impedance	4	8	Ω
Voice coil resistance	4,3	8	Ω
Resonance frequency	42	42	Hz
Power handling capacity, measured without filter, mounted in 25 l sealed enclosure	30	30	W
Operating power	3,4	3,4	W
Sweep voltage	5	7	V
Energy in air gap	135	140	mJ
Flux density	0,87	0,93	T
Air-gap height	5	5	mm
Voice coil height	11	11	mm
Core diameter	25	25	mm
Magnet material	FXD	FXD	
diameter	72	72	mm
mass	0,26	0,26	kg
Mass of loudspeaker	0,8	0,8	kg

The loudspeaker has a rubber surround.

Connection to the loudspeaker by means of 6,3 mm(0,25 inch) Fastons or soldering.

Dimensions (mm)

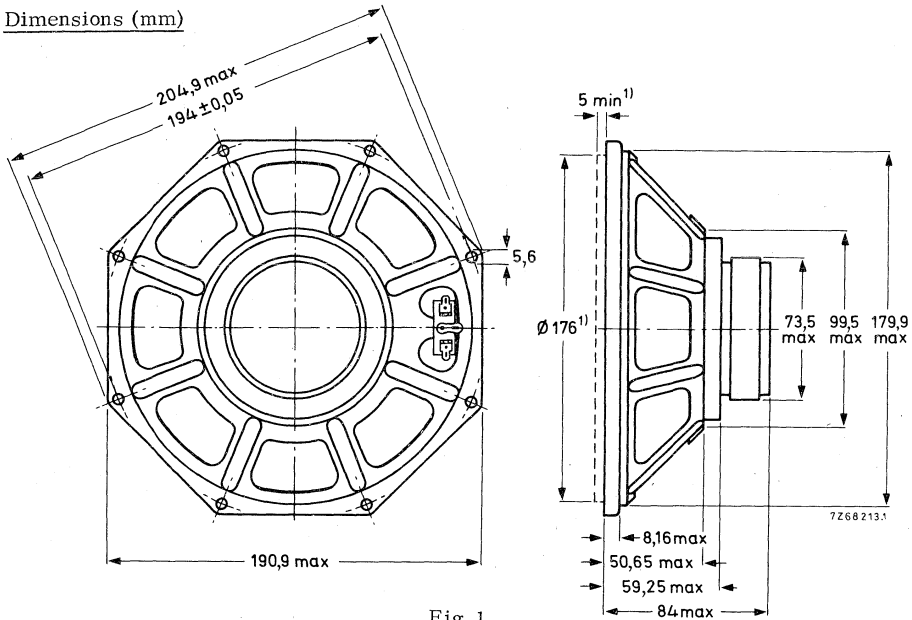

Fig. 1

1) Baffle hole and clearance depth required for cone movement at the specified power handling capacity.

One tag is indicated by a red mark for in-phase connection.

AVAILABLE VERSIONS

AD8061/W4, catalogue number 2422 257 384.5

AD8061/W8, catalogue number 2422 257 384.6

(0 = stamped on loudspeaker magnet, not to be used for ordering)

2 = for bulk packing *)

6 = for single unit packing

FREQUENCY RESPONSE CURVES

See Fig. 2

Curve b: Sound pressure measured in anechoic room at operating power. Loudspeaker mounted in sealed 80 l enclosure, filled with 1 kg of glass wool.

Curve c: 2nd and 3rd harmonic distortion, measured at the operating power of 3, 4 W in anechoic room, loudspeaker mounted in 80 l enclosure, filled with 1 kg of glass wool.

*) Minimum packing quantity 3 per unit.

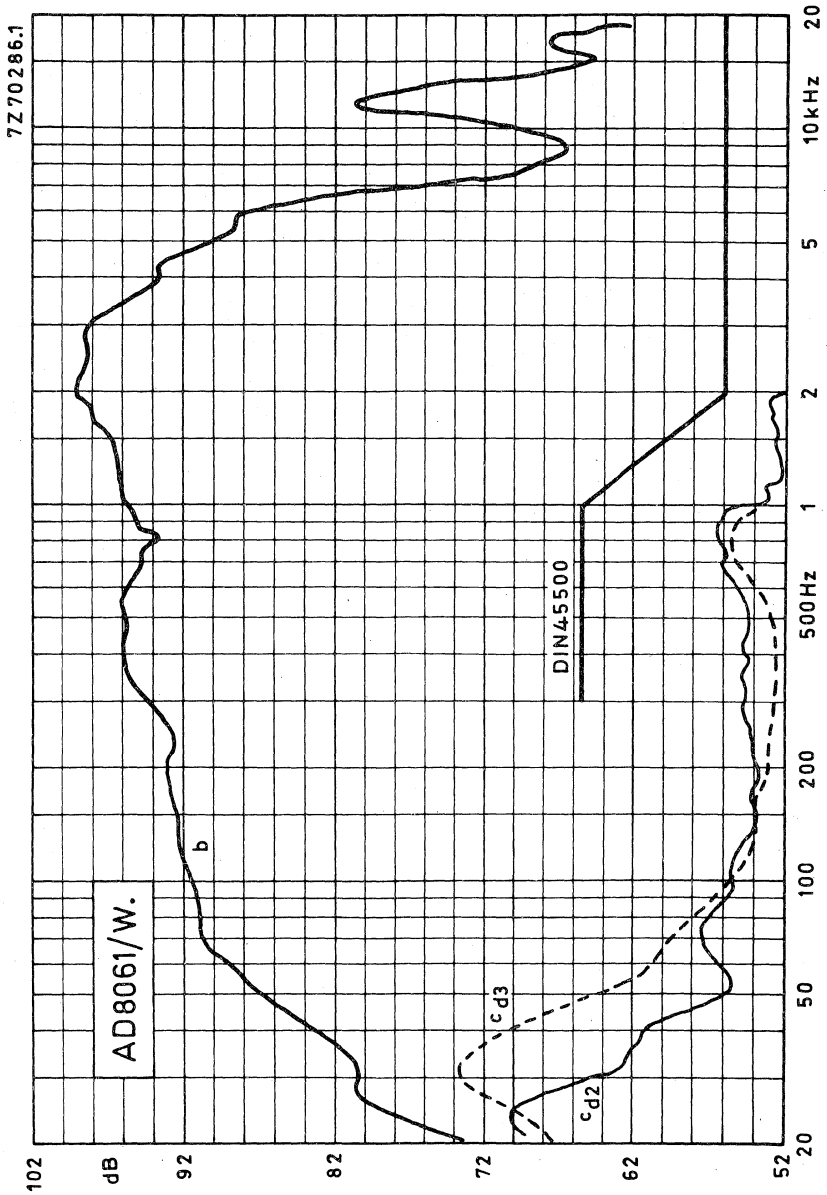

Fig. 2



8 inch HIGH POWER WOOFER LOUDSPEAKER

APPLICATION

For high fidelity reproduction in sealed acoustic enclosures. Maximum enclosure volume 25 litres. Maximum recommended cross-over frequency 2500 Hz. Rated frequency range 30 to 5000 Hz.

TECHNICAL DATA

	version		
	W4	W8	
Rated impedance	4	8	Ω
Voice coil resistance	4,3	8	Ω
Resonance frequency	39	39	Hz
Power handling capacity, measured without filter, mounted in 25 l sealed enclosure	40	40	W
Operating power	2,5	2,5	W
Sweep voltage	5	7	V
Energy in air gap	229	203	mJ
Flux density	1,1	1,2	T
Air-gap height	5	5	mm
Voice coil height	11	11	mm
Core diameter	25	25	mm
Magnet material	FXD	FXD	
diameter	90	90	mm
mass	0,45	0,45	kg
Mass of loudspeaker	1,15	1,15	kg

The loudspeaker has a rubber surround.

Connection to the loudspeaker by means of 6,3 mm (0,25 inch) Fastons or soldering.

Dimensions (mm)

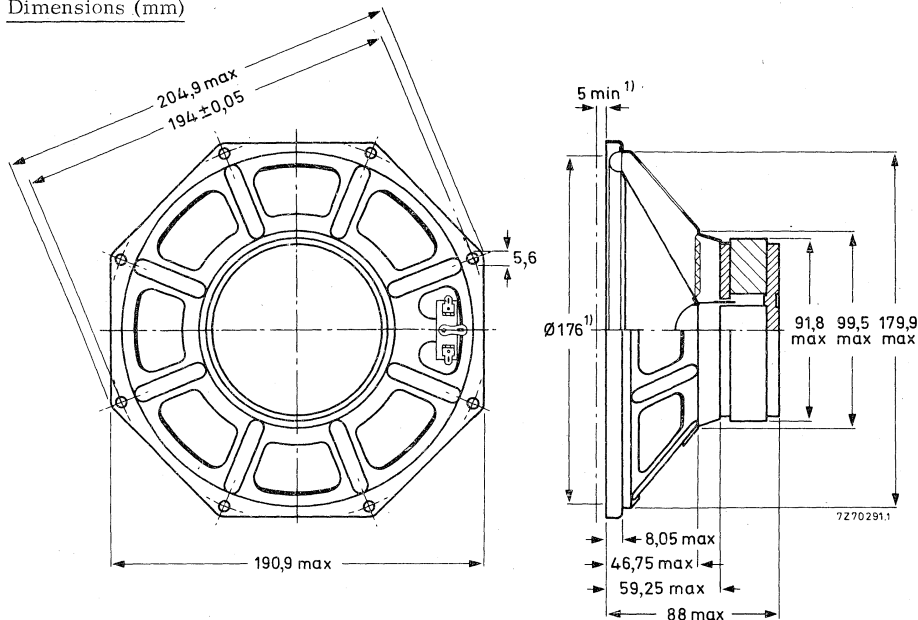

Fig. 1

1) Baffle hole and clearance depth required for cone movement at the specified power handling capacity.

One tag is indicated by a red mark for in-phase connection.

AVAILABLE VERSIONS

AD8066/W4, catalogue number 2422 257 385.1

AD8066/W8, catalogue number 2422 257 385.2

- (0 = stamped on loudspeaker magnet, not to be used for ordering)
- 2 = for bulk packing *)
- 6 = for single unit packing

FREQUENCY RESPONSE CURVES

See Fig. 2

Curve b: Sound pressure measured in anechoic room at operating power. Loudspeaker mounted in sealed 80 l enclosure, filled with 1 kg of glass wool.

Curve c: 2nd and 3rd harmonic distortion, measured at the operating power of 2,5 W in anechoic room, loudspeaker mounted in sealed 80 l enclosure, filled with 1 kg of glass wool.

) Minimum packing quantity 3 per unit.

8 inch HIGH POWER WOOFER
LOUDSPEAKER

AD8066/W.

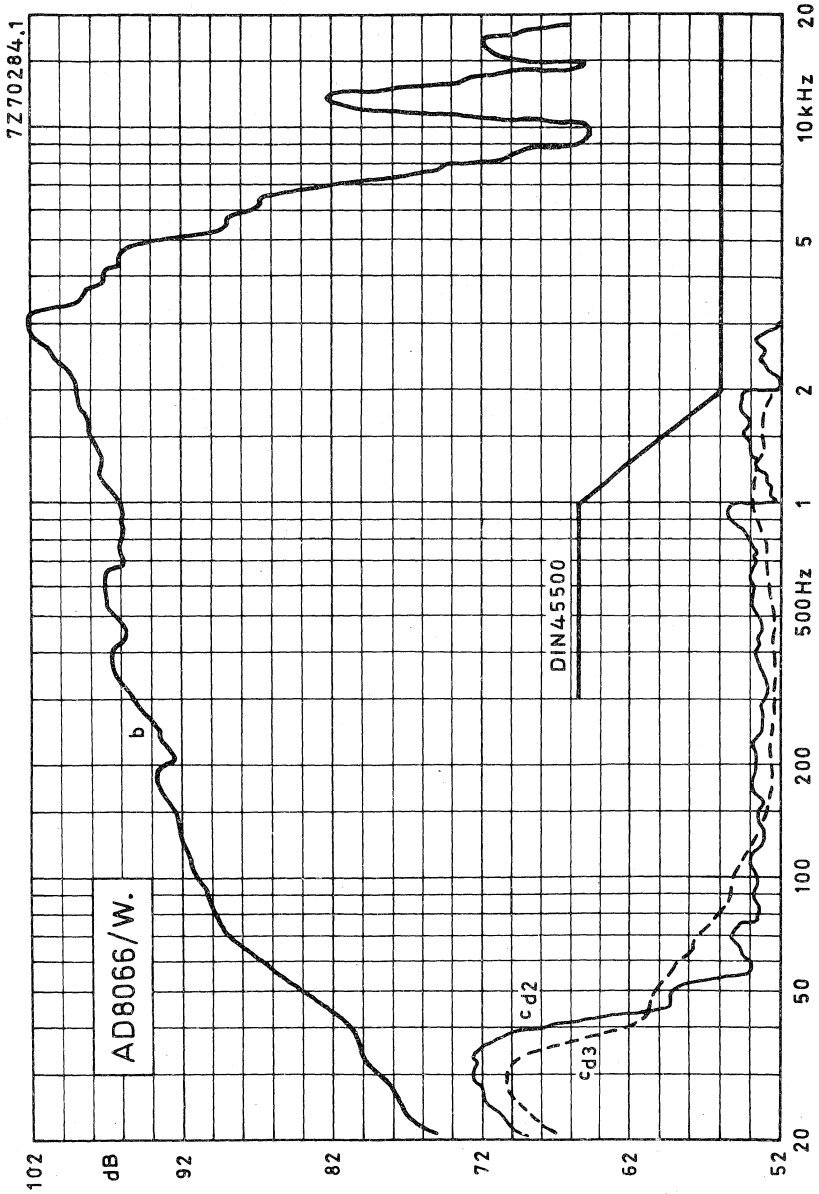

Fig. 2



8 inch HIGH POWER MOTIONAL FEEDBACK LOUDSPEAKER

APPLICATION

For application in small enclosures with very low bass response down to 20 Hz with excellent distortion suppression.

The loudspeaker has a built-in acceleration sensor.

Rated frequency range 25 to 1000 Hz.

TECHNICAL DATA

Rated impedance	4 Ω
Voice coil resistance	4 Ω
Resonance frequency	38 Hz
Power handling capacity, measured with filter *) mounted in 91 sealed enclosure	50 W
Operating power	11 W
Sweep voltage frequency range: 35-1000 Hz	5 V
Energy in air gap	225 mJ
Flux density	0,69 T
Air-gap height	5 mm
Voice coil height	12,7 mm
Core diameter	34 mm
Magnet material	FXD
diameter	90 mm
mass	0,42 kg
Mass of loudspeaker	1,3 kg

The loudspeaker has a paper cone and rubber surround.

Connection to the loudspeaker by means of soldering or Fastons : voice coil 6,3 mm (0,25 inch); acceleration sensor: 3,2 mm (0,12 inch).

*) Filter characteristic :

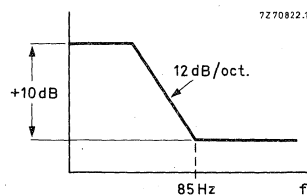

Dimensions (mm)

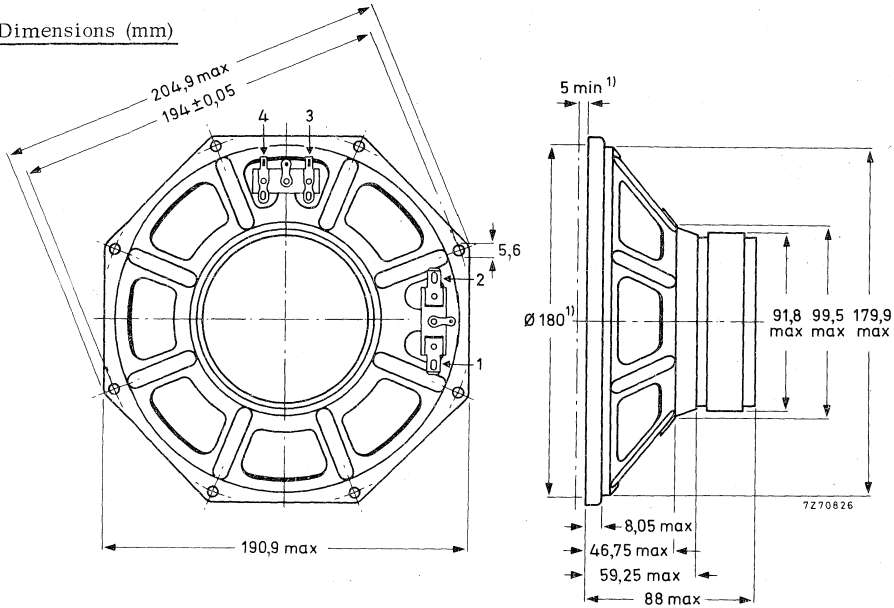

- voice coil { 1 red dot mark for in-phase connection
- 2
- acceleration sensor { 3 3
- 4 4

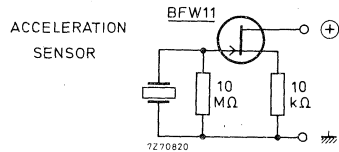

Fig. 1

1) Baffle hole and mounting clearance depth required for cone movement at the specified power handling capacity.

AVAILABLE VERSION

- AD8067/MFB, catalogue number 2422 257 386.5
- (0 = stamped on loudspeaker magnet, not to be used for ordering)
- 2 = for bulk packing *)
- 6 = for single unit packing

FREQUENCY RESPONSE CURVES (see Fig.2)

Curve b: Sound pressure measured in anechoic room at an operating power of 11 W. Loudspeaker mounted in sealed 80 l enclosure, filled with 1 kg of glass wool.

Curve c: 2nd and 3rd harmonic distortion, measured at the operating power of 11 W in anechoic room, loudspeaker mounted in sealed 80 l enclosure, filled with 1 kg of glass wool.

*) Minimum packing quantity 3 per unit.

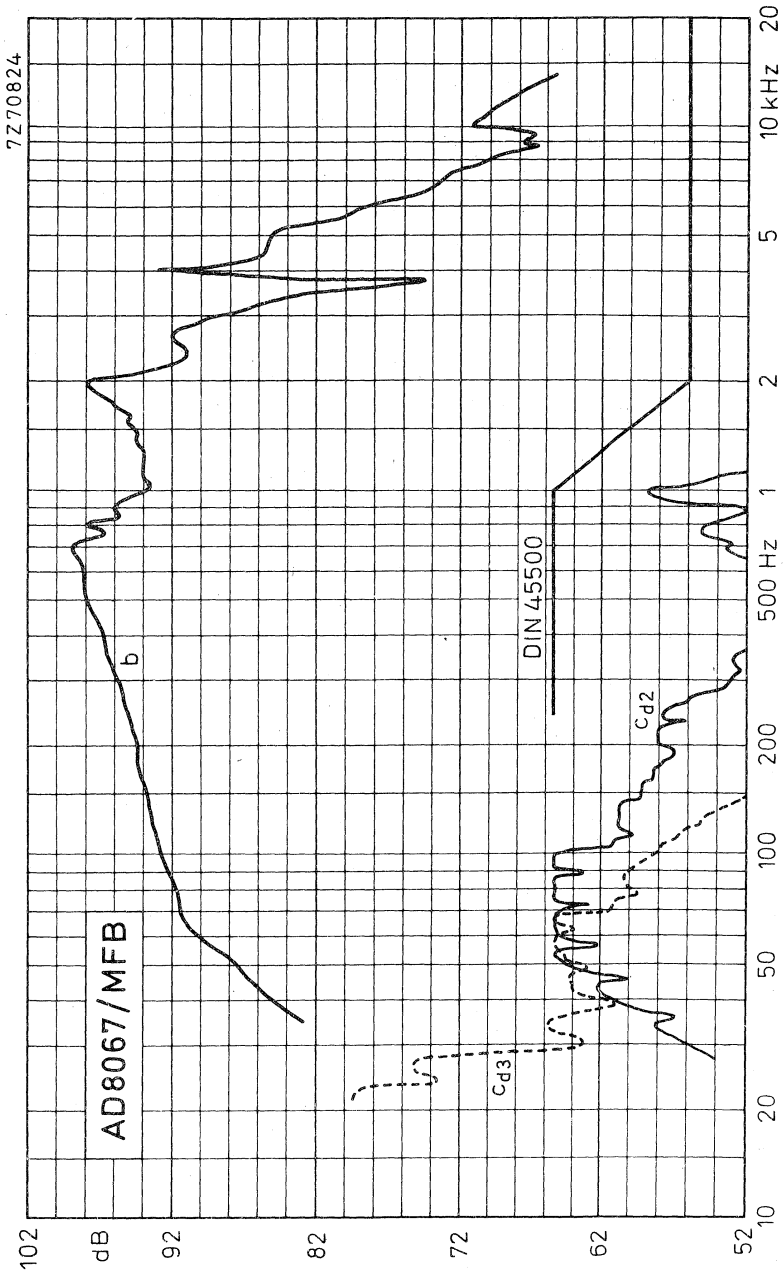

Fig. 2



COIL ACCELERATION RESPONSE CURVE (see Fig. 4)

Test conditions :

Loudspeaker unmounted.

Input at voice coil connections : 0,44 V (50 mW/4 Ω)

Test circuit

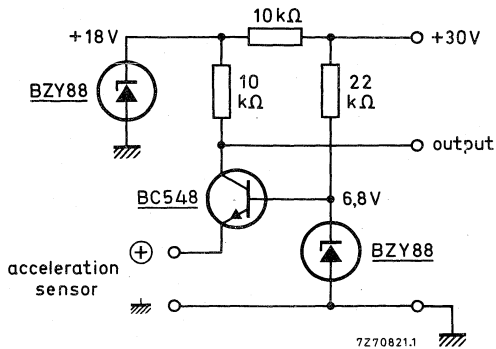

Fig. 3

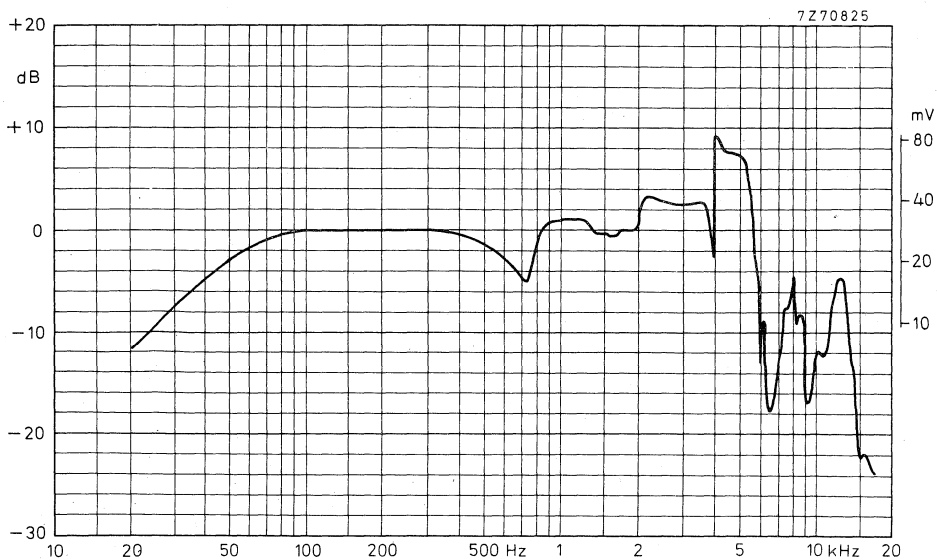

Fig. 4

Phase relation between output voltage of acceleration sensor and input voltage on voice coil

- : V_{out} lagging

+ : V_{out} leading

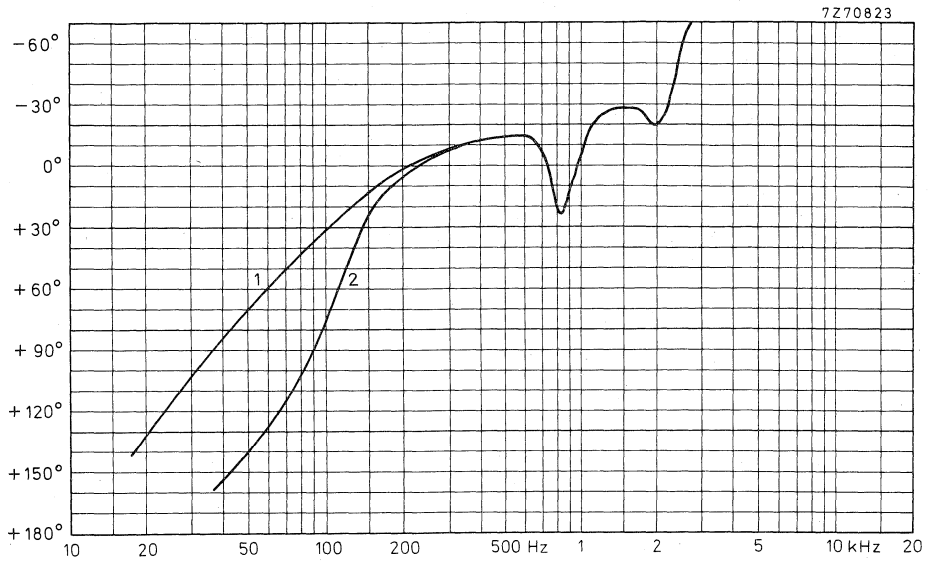

Fig. 5

Curve 1: loudspeaker unmounted; $f_{res} = 26$ Hz.

Curve 2: loudspeaker mounted in sealed 9 l enclosure; $f_{res} = 84$ Hz.

DEVELOPMENT SAMPLE DATA

This information is derived from development samples made available for evaluation. It does not form part of our data handbook system and does not necessarily imply that the device will go into production

AD8067/W.**8 inch HIGH POWER WOOFER LOUDSPEAKER****APPLICATION**

For high fidelity reproduction according to DIN45500 in sealed acoustic enclosures. Maximum enclosure volume 25 litres. Maximum recommended cross-over frequency 3000 Hz.

TECHNICAL DATA

	version		
	W4	W8	
Rated impedance	4	8	Ω
Voice coil resistance	3,2	6,4	Ω
Resonance frequency	32	32	Hz
Power handling capacity, measured without filter, mounted in 25 l enclosure	40	40	W
Operating power	6	6	W
Sweep voltage	5	7	V
Energy in air gap	225	225	mJ
Flux density	0,7	0,7	T
Air-gap height	5	5	mm
Voice coil height	12,7	12,8	mm
Core diameter	34	34	mm
Magnet material	FXD	FXD	
diameter	90	90	mm
mass	0,42	0,42	kg
Mass of loudspeaker	1,3	1,3	kg

The loudspeaker has a rubber surround.

Connection to the loudspeaker by means of 6,3 mm (0,25 inch) Fastons or soldering.

Dimensions (mm)

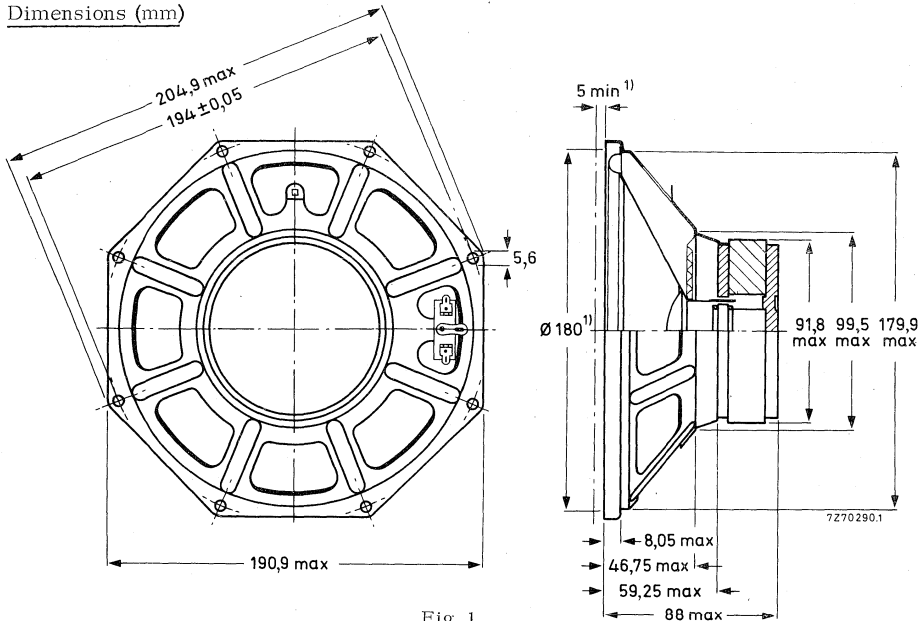

Fig. 1

1) Baffle hole and clearance depth required for cone movement at the specified power handling capacity.

One tag is indicated by a red mark for in-phase connection.

AVAILABLE VERSIONS

AD8067/W4, catalogue number 2422 257 386.1

AD8067/W8, catalogue number 2422 257 386.2

(0 = stamped on loudspeaker magnet, not to be used for ordering)

2 = for bulk packing *)

6 = for single unit packing

FREQUENCY RESPONSE CURVES

See Fig. 2

Curve a : Sound pressure measured in anechoic room, loudspeaker unmounted.

Above 1000 Hz the sound pressure may be, over the width of one octave, maximum 2 dB lower than indicated. Input power 50 mW (0,44 V).

Curve b : Sound pressure measured in half free field at operating power. Loudspeaker mounted in sealed 80 l enclosure, filled with 1 kg of glass wool.

Curve c : 2nd and 3rd harmonic distortion, measured at the operating power of 6 W in anechoic room, loudspeaker mounted in sealed 80 l enclosure, filled with 1 kg of glass wool.

Curve e : Maximum distortion according DIN45500, Blatt 7.

*) Minimum packing quantity 3 per unit.

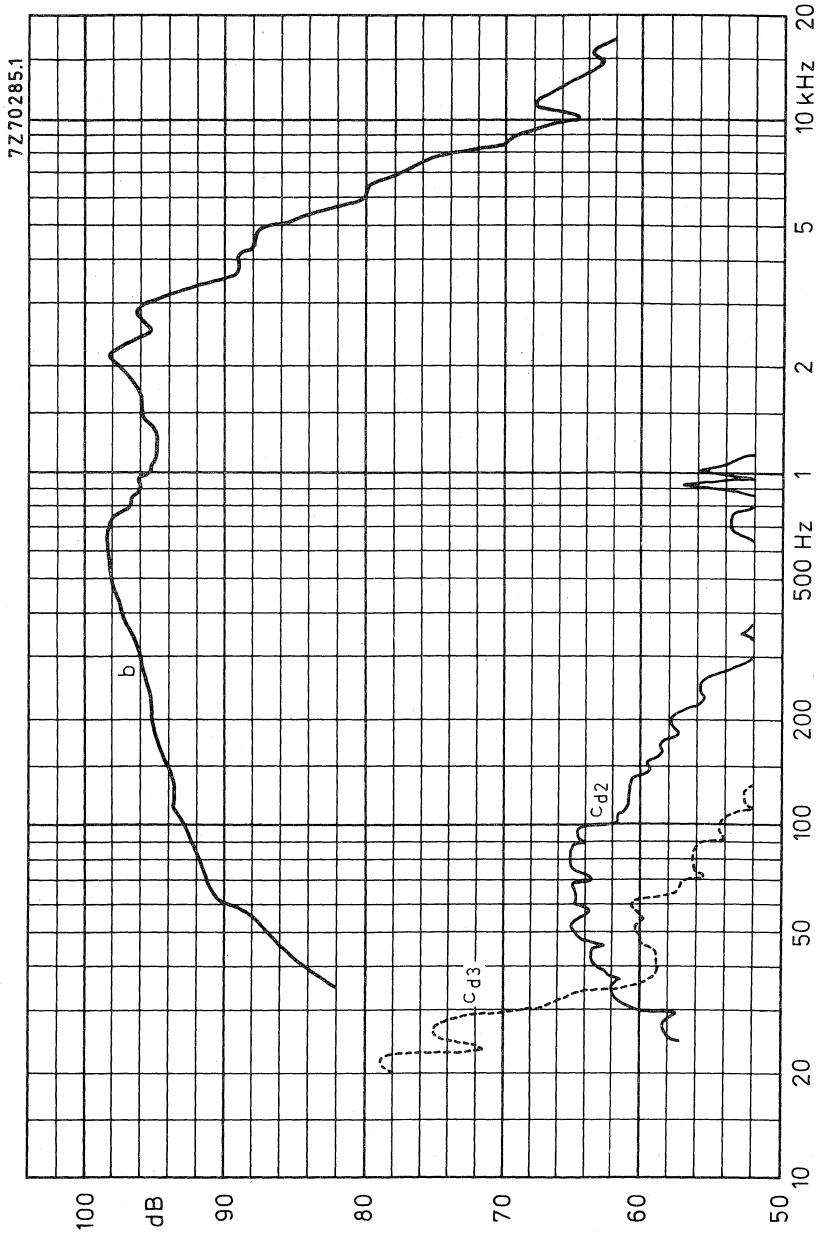

Fig. 2



DEVELOPMENT SAMPLE DATA

This information is derived from development samples made available for evaluation. It does not form part of our data handbook system and does not necessarily imply that the device will go into production

AD8081/M.**8 inch OCTAGONAL MEDIUM POWER LOUDSPEAKERS****APPLICATION**

A full range loudspeaker for domestic radios, public address systems, and ceiling sets. Due to its dual-cone construction, this loudspeaker has an extended frequency response up to 20 kHz.

TECHNICAL DATA

	version		
	M4	M8	
Rated impedance	4	8	Ω
Voice coil resistance	3, 4	7, 1	Ω
Rated frequency range	50 to 14 000		Hz
Resonance frequency	75		Hz
Power handling capacity, measured without filter, loudspeaker unmounted	8		W
Operating power (sound level 90 dB, 1 m)	1		W
Sweep voltage (40 to 20 000 Hz)	4	5, 5	V
Energy in air gap	50	53	mJ
Flux density	0, 95	0, 98	T
Air gap height	3		mm
Voice coil height	6	5, 3	mm
Core diameter	18		mm
Magnet material	Ferroxdure		
diameter	53		mm
mass	0, 1		kg
Mass of loudspeaker	0, 37		kg

The loudspeaker has a paper rim.

Dimensions (mm)

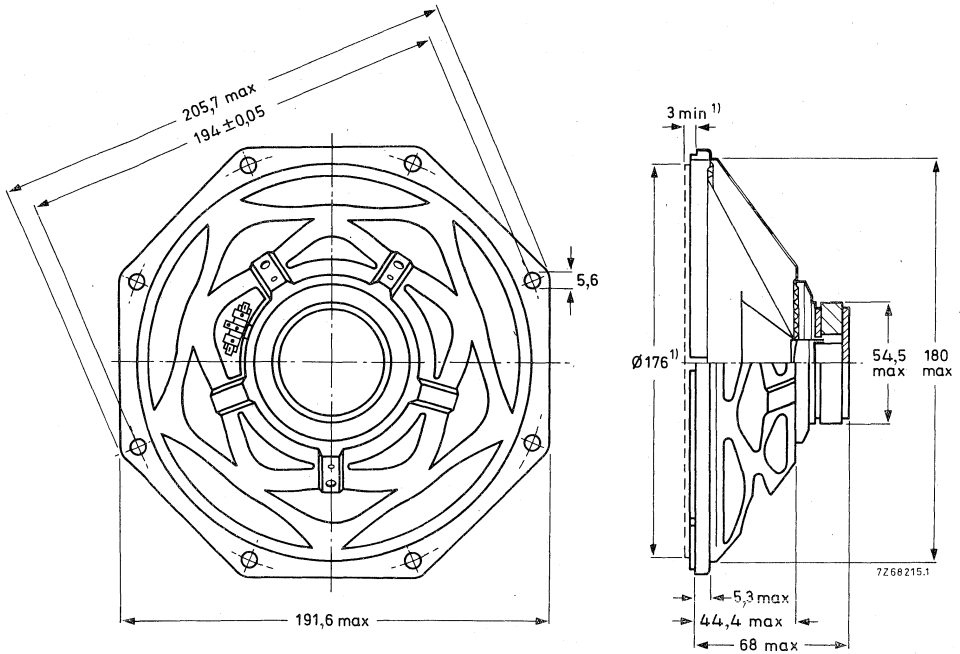

Fig. 1

¹⁾ Baffle hole and clearance depth required for cone movement at the specified power handling capacity.

One tag is indicated by a red mark for in-phase connection.

AVAILABLE VERSIONS

AD8081/M4, catalogue number 2422 257 382.1

AD8081/M8, catalogue number 2422 257 382.2

(1 = stamped on loudspeaker magnet,
not to be used for ordering)

3 = for bulk packing*)

7 = for single unit packing

FREQUENCY RESPONSE CURVES (see Fig. 2)

Curve b: Sound pressure measured in anechoic room, loudspeaker mounted on baffle according to IEC268-5, par. 4. 4.

Curve c: 2nd and 3rd harmonic distortion, measured at the operating power of 1 W in anechoic room. Loudspeaker front mounted on IEC baffle.

*) Minimum packing quantity 4 per unit.

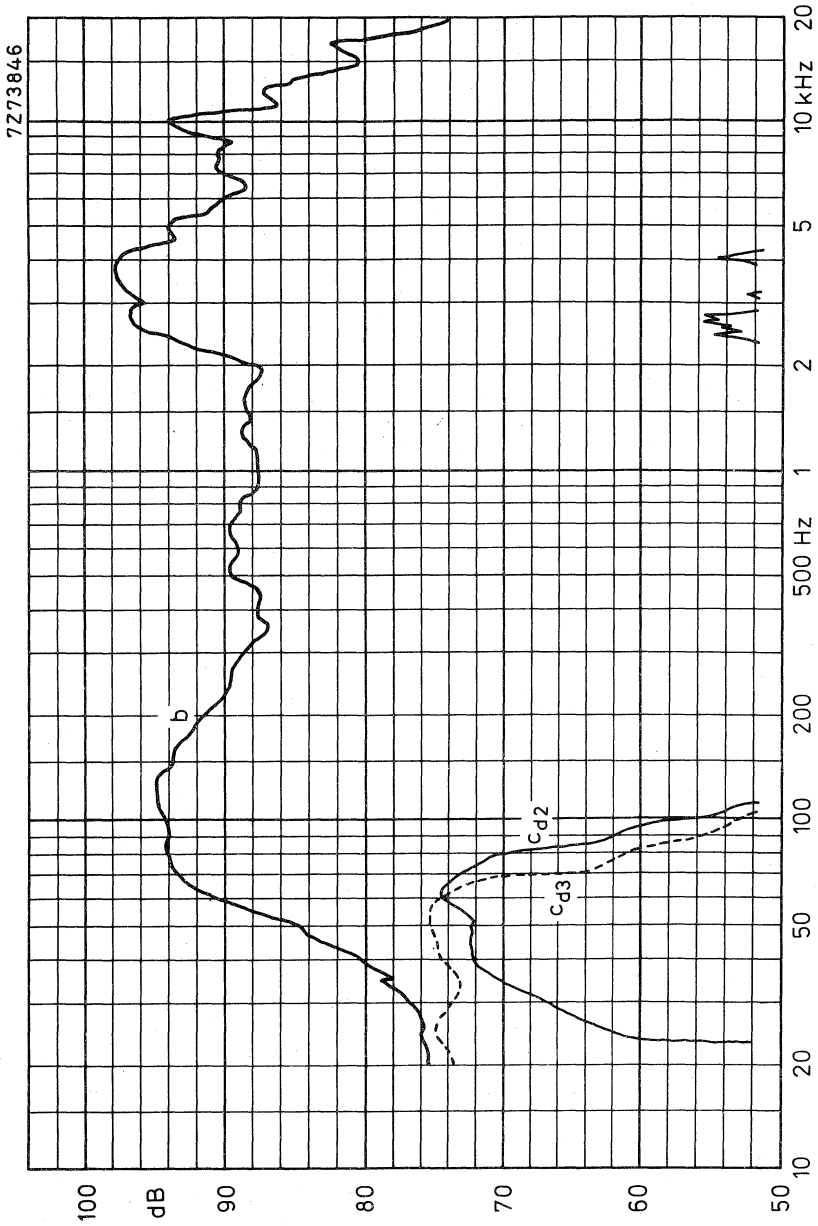

Fig.2



DEVELOPMENT SAMPLE DATA

This information is derived from development samples made available for evaluation. It does not form part of our data handbook system and does not necessarily imply that the device will go into production

AD8081/X.**8 inch OCTAGONAL MEDIUM POWER LOUDSPEAKERS****APPLICATION**

For domestic radios, public address systems, and ceiling sets. High sensitivity at 4000 Hz.

TECHNICAL DATA

	version		
	X4	X8	
Rated impedance	4	8	Ω
Voice coil resistance	3,4	7,1	Ω
Rated frequency range	70 to 11 000		Hz
Resonance frequency	95		Hz
Power handling capacity, measured without filter, loudspeaker unmounted	8		W
Operating power (sound level 90 dB, 1 m)	0,7		W
Sweep voltage (50 to 20 000 Hz)	4	5,6	V
Energy in air gap	53		mJ
Flux density	0,98		T
Air gap height	3		mm
Voice coil height	6	5,3	mm
Core diameter	18		mm
Magnet material	Ferrodure		
diameter	53		mm
mass	0,1		kg
Mass of loudspeaker	0,37		kg

The loudspeaker has a paper rim.

Dimensions (mm)

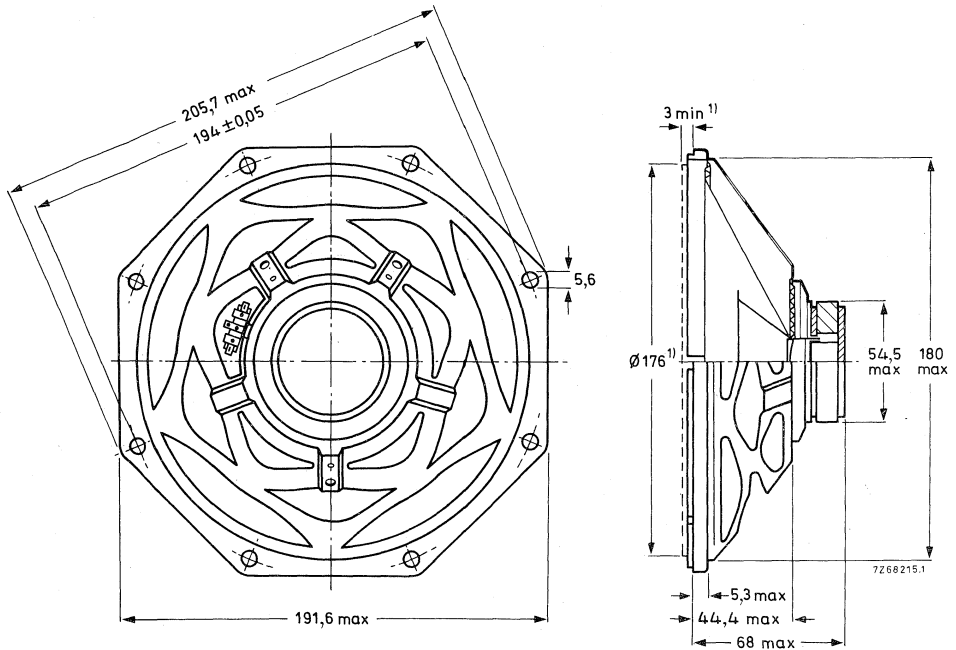

Fig. 1

1) Baffle hole and clearance depth required for cone movement at the specified power handling capacity.

One tag is indicated by a red mark for in-phase connection.

AVAILABLE VERSIONS

AD8081/X4, catalogue number 2422 257 382.3
AD8081/X8, catalogue number 2422 257 382.4

(1 = stamped on loudspeaker magnet, not to be used for ordering)

3 = for bulk packing *)

7 = for single unit packing

FREQUENCY RESPONSE CURVES (see Fig. 2)

Curve b: Sound pressure measured in anechoic room, loudspeaker mounted on baffle according to IEC268-5, par. 4.4.

Curve c: 2nd and 3rd harmonic distortion, measured at the operating power of 0,7 W in anechoic room. Loudspeaker front mounted on IEC baffle.

*) Minimum packing quantity 4 per unit.

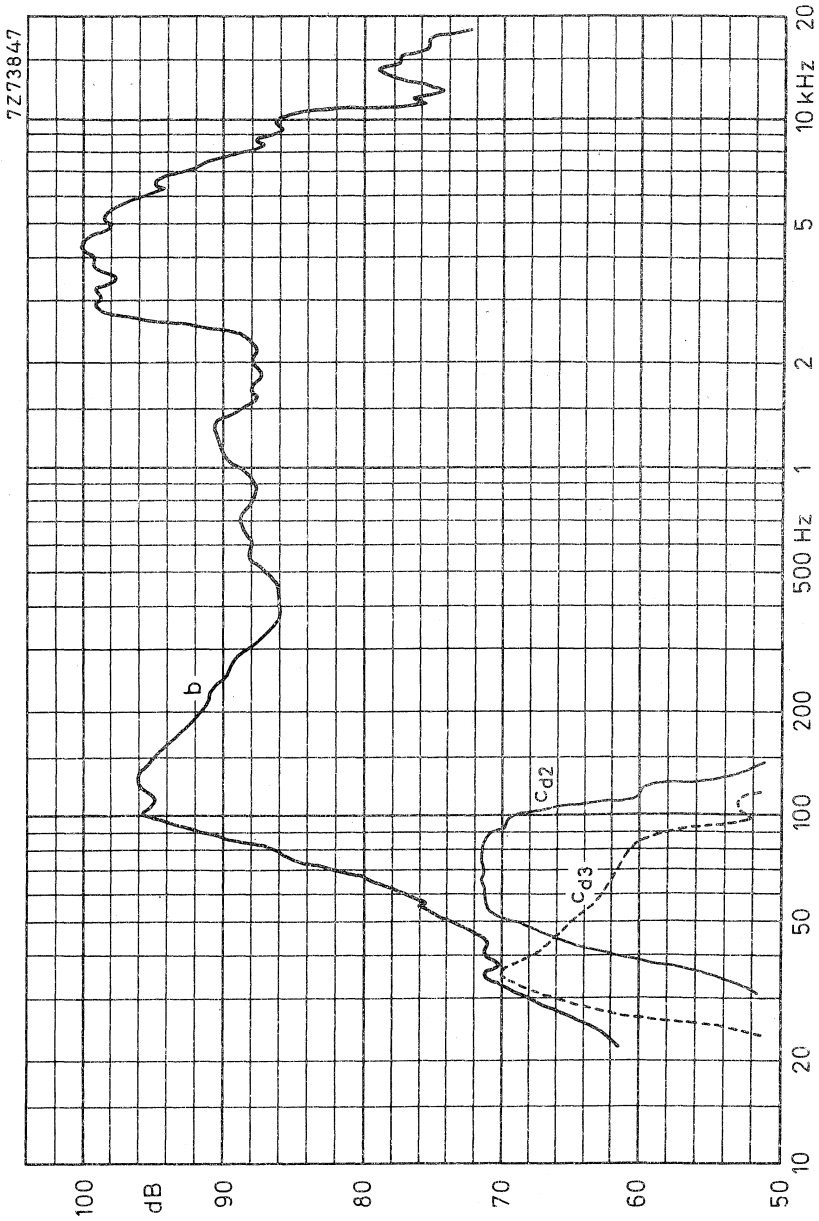

Fig. 2



8½ inch HIGH POWER FULL RANGE LOUDSPEAKER

APPLICATION

A full range loudspeaker for studio monitoring equipment and domestic bass reflex enclosures for high fidelity reproduction from 45 Hz to 19 kHz.

TECHNICAL DATA

	<u>version MC</u>	
Rated impedance	7	Ω
Voice coil resistance	5	Ω
Resonance frequency	50	Hz
Power handling capacity, measured without filter,		
loudspeaker mounted in sealed enclosure < 30 l	20	W
loudspeaker mounted in sealed enclosure > 30 l	10	W
Operating power	1,3	W
Sweep voltage	5,9	V
Energy in airgap	361	mJ
Flux density	0,75	T
Airgap height	11	mm
Voice coil height	7	mm
Core diameter	34	mm
Magnet material	Fxd	
diameter	105	mm
weight	0,4	kg
Weight of loudspeaker	1,75	kg

The loudspeaker has a paper cone and surround and a cork gasket on the flange.

Connection to the loudspeaker by means of 6,3 mm (0,25 inch) Fastons or soldering.

Dimensions (mm)

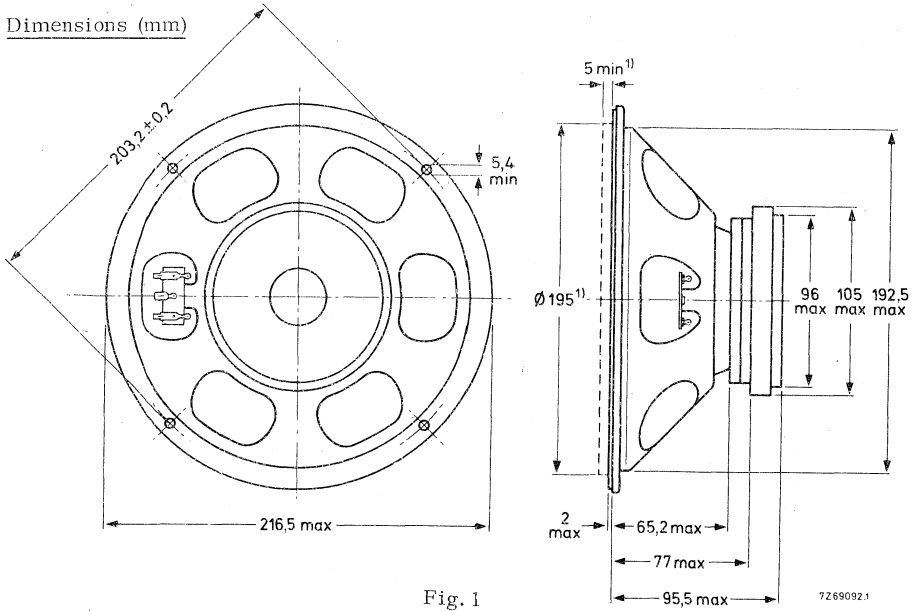

Fig. 1

1) Baffle hole and clearance depth required for cone movement at the specified power handling capacity.

One tag is indicated by a red mark for in-phase connection.

AVAILABLE VERSION

9710/MC, catalogue number 2422 257 481, 1

- (0 = stamped on loudspeaker magnet, not to be used for ordering)
- 2 = for bulk packing *)
- 6 = for single unit packing

FREQUENCY RESPONSE CURVES

See Fig. 2.

Curve b: Sound pressure measured in anechoic room, loudspeaker mounted in sealed 80 l enclosure. Input power at operating power of 1, 3 W.

Curve c: 2nd and 3rd harmonic distortion, measured at the operating power of 0, 7 W in anechoic room, loudspeaker mounted in sealed 80 l enclosure, filled with 1 kg of glass wool.

*) Minimum packing quantity 2 per unit.

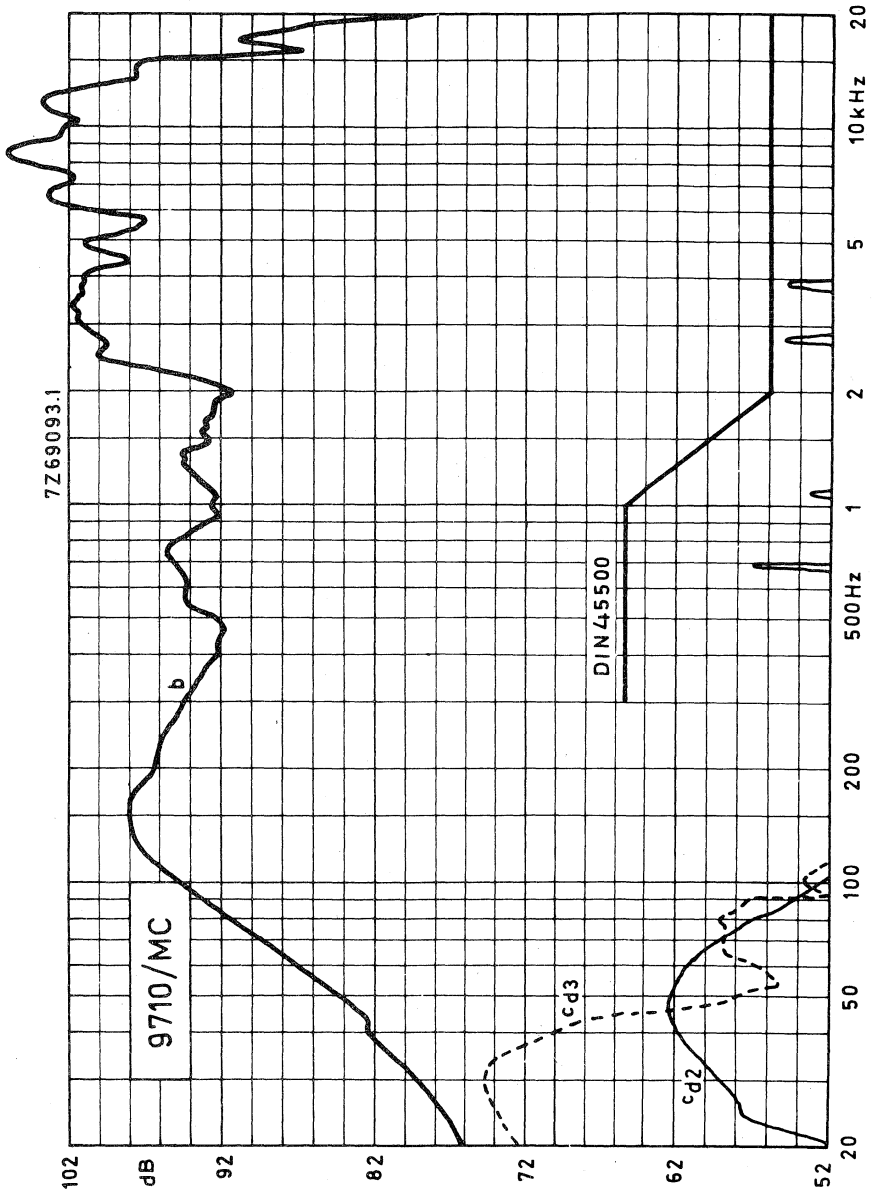

Fig. 2



10 inch HIGH POWER FULL RANGE LOUDSPEAKER

APPLICATION

A full range loudspeaker with high sensitivity for public address systems in enclosures greater than 20 litres.

Smooth response from 60 Hz to 18 000 Hz.

TECHNICAL DATA

	version			
	M4	M8	M15	
Rated impedance	4	8	15	Ω
Voice coil resistance	3, 4	7	13	Ω
Resonance frequency	55	55	55	Hz
Power handling capacity, measured without filter, loudspeaker unmounted	10	10	10	W
Operating power	1, 5	1, 5	1, 5	W
Sweep voltage	4, 5	6, 3	8, 7	V
Energy in airgap	225	225	225	mJ
Flux density	1, 12	1, 12	1, 12	T
Airgap height	5	5	5	mm
Voice coil height	6, 5	6, 5	4, 5	mm
Core diameter	25	25	25	mm
Magnet material	Fxd	Fxd	Fxd	
diameter	90	90	90	mm
weight	0, 45	0, 45	0, 45	kg
Weight of loudspeaker	1, 52	1, 52	1, 52	kg

The loudspeaker has a paper surround and a double cone.

Connection to the loudspeaker by means of 6, 3 mm (0, 25 inch) Fastons or soldering.

Dimensions (mm)

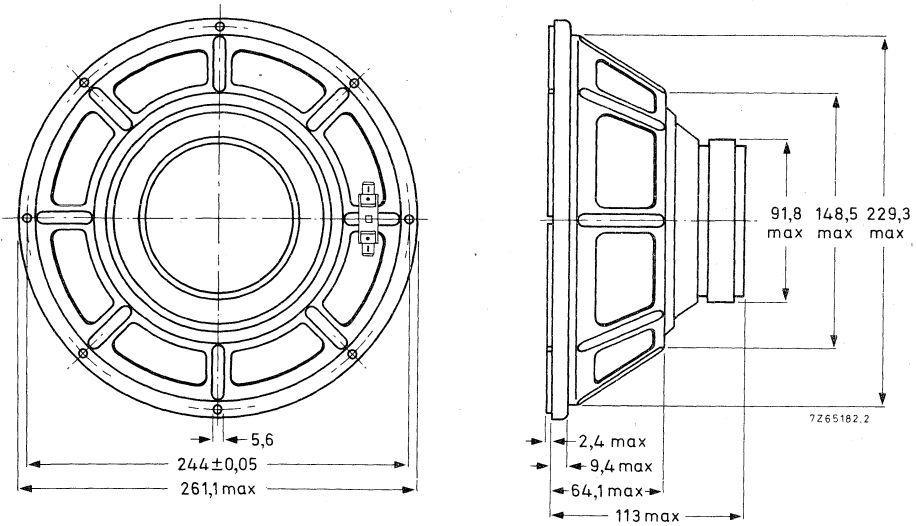

Fig. 1

Baffle hole diameter 227 mm

One tag is indicated by a red mark for in-phase connection.

AVAILABLE VERSIONS

AD1065/M4, catalogue number 2422 257 410.1

AD1065/M8, catalogue number 2422 257 410.2

AD1065/M15, catalogue number 2422 257 410.3

(0 = stamped on loudspeaker magnet,
not to be used for ordering)

2 = for bulk packing *)
6 = for single unit packing

FREQUENCY RESPONSE CURVES (see Fig. 2)

Curve b : Sound pressure measured in anechoic room at operating power of 1,5 W.
Loudspeaker mounted in sealed 80 l enclosure, filled with 1 kg of glass wool.

Curve c : 2nd and 3rd harmonic distortion, measured at operating power of 1,5 W in anechoic room. Loudspeaker mounted in 80 l enclosure, filled with 1 kg of glass wool.

*) Minimum packing quantity 1 per unit.

10 inch HIGH POWER FULL RANGE
LOUDSPEAKER

AD1065/M.

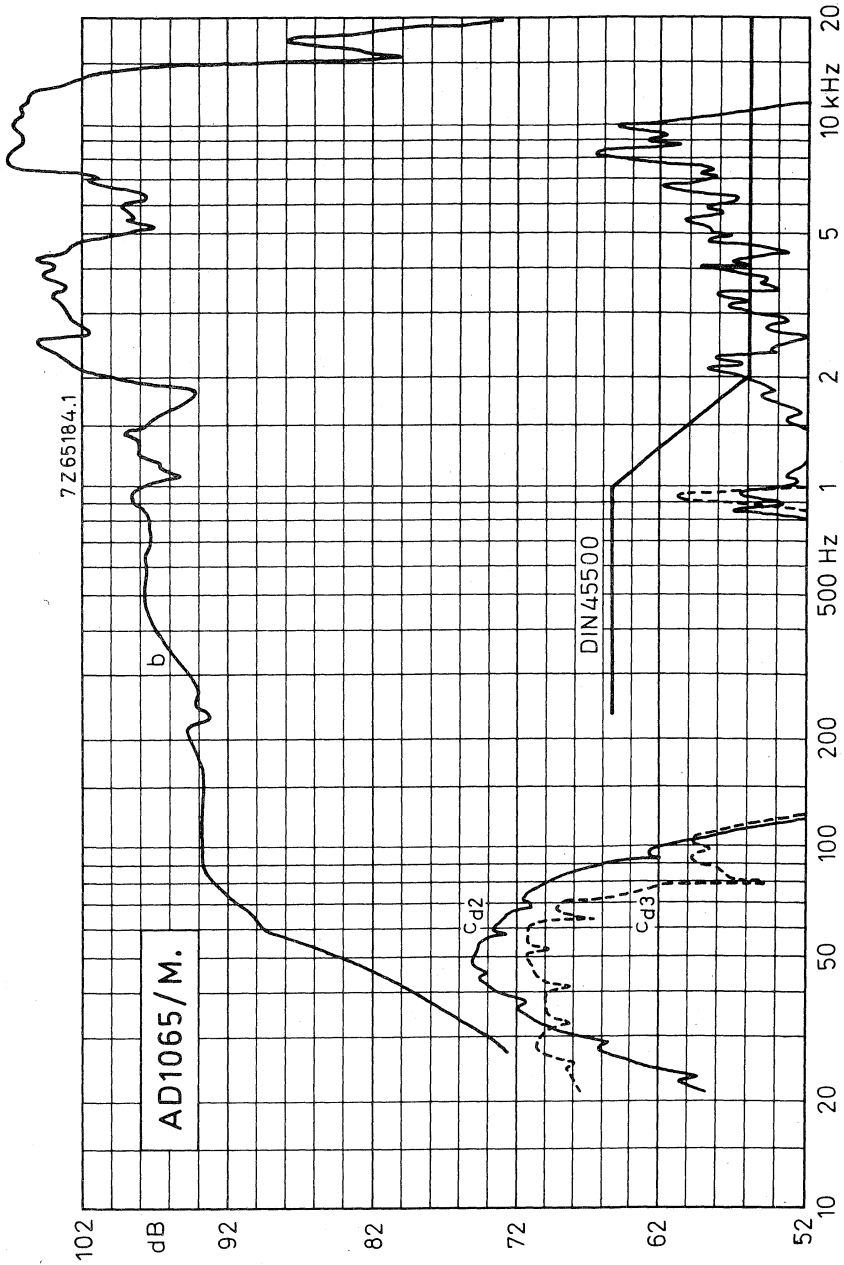

Fig. 2



10 inch HIGH POWER WOOFER LOUDSPEAKER

APPLICATION

For high fidelity reproduction in sealed acoustic enclosures in accordance with DIN 45500. Recommended enclosure volume 35 litres. Maximum recommended cross-over frequency 1000 Hz. Rated frequency range 40 to 3000 Hz.

TECHNICAL DATA

	version		
	W4	W8	
Rated impedance	4	8	Ω
Voice coil resistance	3,2	6,8	Ω
Resonance frequency	20	20	Hz
Power handling capacity, measured without filter, mounted in 35 l sealed enclosure	30	30	W
Operating power	5	5	W
Sweep voltage	5	7	V
Energy in airgap	280	280	mJ
Flux density	0,94	0,94	T
Airgap height	5	5	mm
Voice coil height	12,1	13,5	mm
Core diameter	25	25	mm
Magnet material	Fxd	Fxd	
diameter	90	90	mm
weight	0,45	0,45	kg
Weight of loudspeaker	1,8	1,8	kg

The loudspeaker has a rubber surround.

Connection to the loudspeaker by means of 6,3 mm (0,25 inch) Fastons or soldering.

Dimensions (mm)

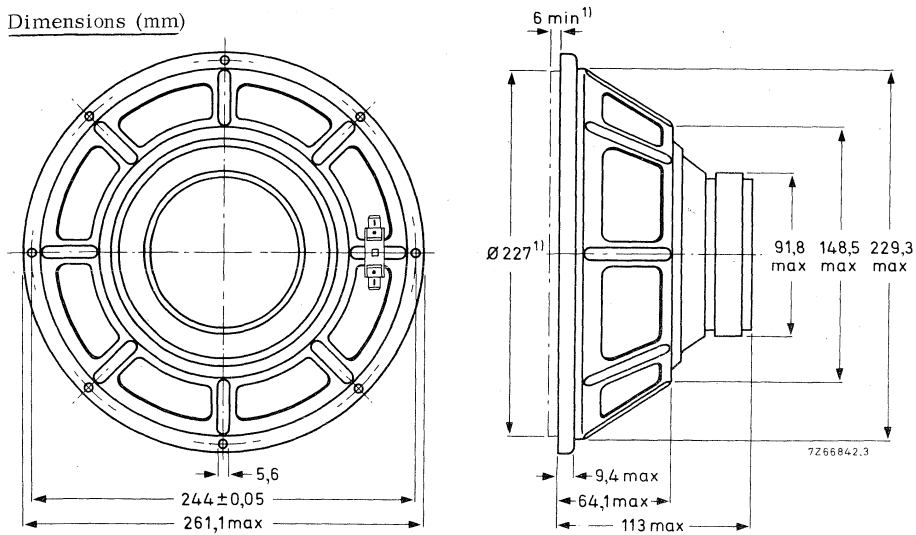

Fig. 1

1) Baffle hole and clearance depth required for cone movement at the specified power handling capacity.

One tag is indicated by a red mark for in-phase connection.

AVAILABLE VERSIONS.

AD 1065/W4, catalogue number 2422 257 313.1

AD 1065/W8, catalogue number 2422 257 313.2

(0 = stamped on loudspeaker magnet,
not to be used for ordering)

2 for bulk packing *)

6 for single unit packing

FREQUENCY RESPONSE CURVES (see Fig. 2)

Curve b : Sound pressure measured in anechoic room at operating power of 5 W.
Loudspeaker mounted in sealed 80 l enclosure, filled with 1 kg of glass wool.

Curve c : 2nd and 3rd harmonic distortion, measured at operating power of 5 W in anechoic room. Loudspeaker mounted in 80 l enclosure, filled with 1 kg of glass wool.

*) Minimum packing quantity 1 per unit.

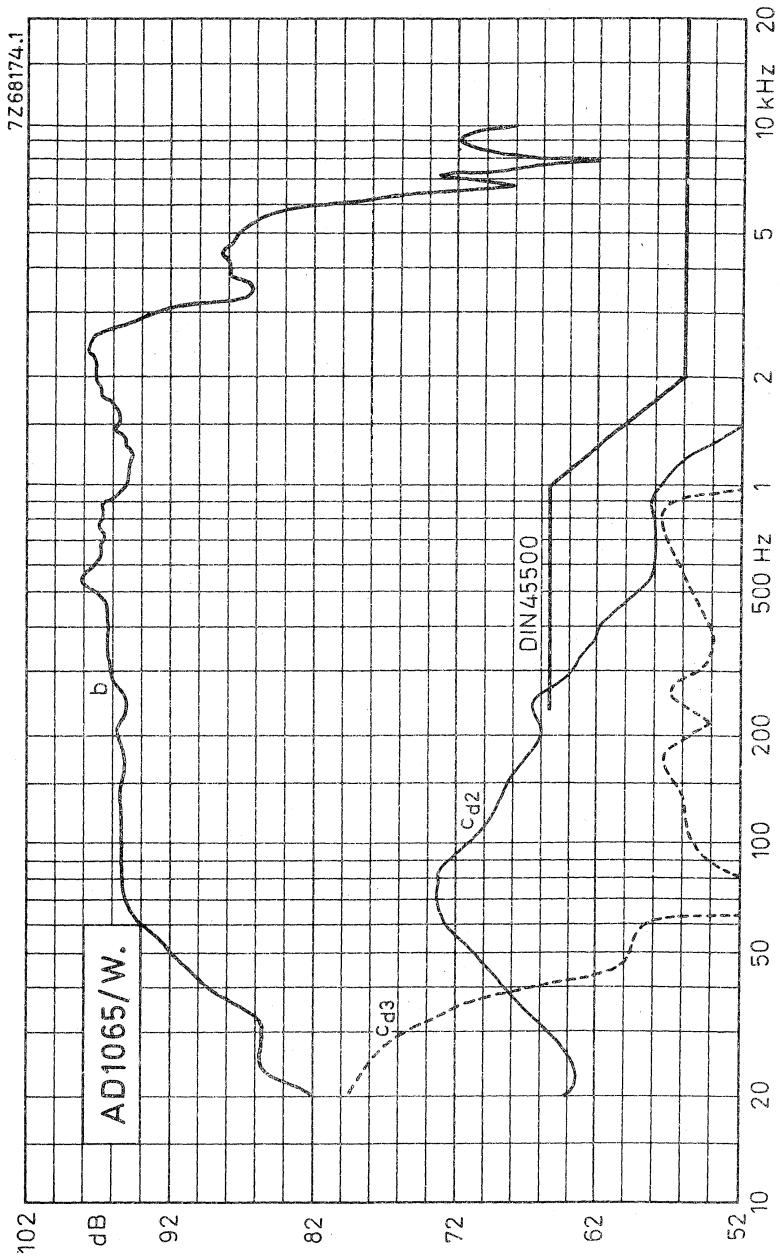

Fig 2



10 inch HIGH POWER WOOFER LOUDSPEAKER

APPLICATION

For high fidelity reproduction in sealed acoustic enclosures in accordance with DIN45500. Recommended enclosure volume 35 litres. Maximum recommended cross-over frequency 800 Hz. Rated frequency range 35 to 800 Hz.

TECHNICAL DATA

	version		
	W4	W8	
Rated impedance	4	8	Ω
Voice coil resistance	3,4	6,5	Ω
Resonance frequency	25	25	Hz
Power handling capacity, measured without filter mounted in 35 l sealed enclosure	40	40	W
Operating power	2,5	2,5	W
Sweep voltage	5	7	V
Energy in airgap	820	820	mJ
Flux density	1,03	1,03	T
Airgap height	8	8	mm
Voice coil height	15	17,2	mm
Core diameter	50	50	mm
Magnet material	Fxd	Fxd	
diameter	130	130	mm
weight	1,05	1,05	kg
Weight of loudspeaker	3,0	3,0	kg

The loudspeaker has a rubber surround.

Connection to the loudspeaker by means of 6,3 mm (0,25 inch) Fastons or soldering.

Dimensions (mm)

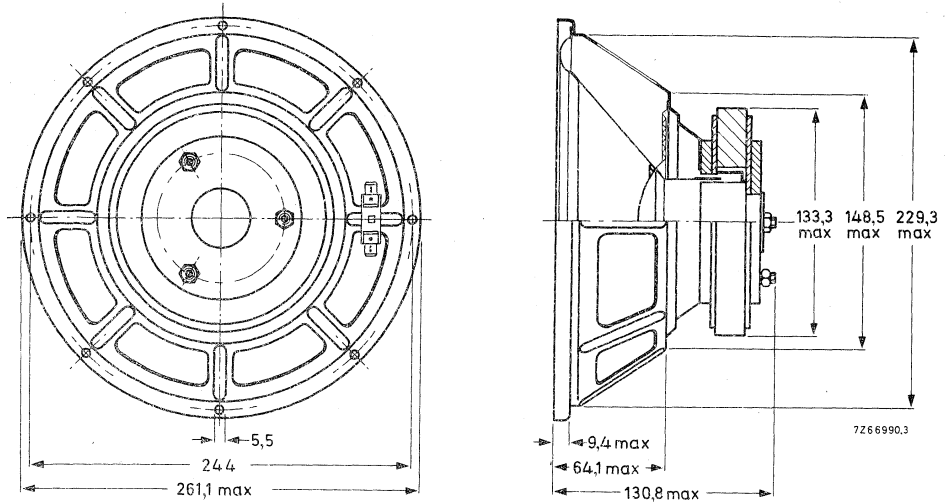

Fig. 1

Baffle hole diameter 227 mm

One tag is indicated by a red mark for in-phase connection.

AVAILABLE VERSIONS

AD 10100/W4. catalogue number 2422 257 412.1

AD 10100/W8. catalogue number 2422 257 412.2

(0 = stamped on loudspeaker magnet,
not to be used for ordering)

2 for bulk packing*)

6 for single unit packing

FREQUENCY RESPONSE CURVES (see Fig. 2)

Curve b : Sound pressure measured in anechoic room at operating power of 2,5 W.

Loudspeaker mounted in sealed 80 l enclosure, filled with 1 kg of glass wool.

Curve c : 2nd and 3rd harmonic distortion, measured at operating power of 2,5 W in anechoic room. Loudspeaker mounted in sealed 80 l enclosure, filled with 1 kg of glass wool.

*) Minimum packing quantity 1 per unit.

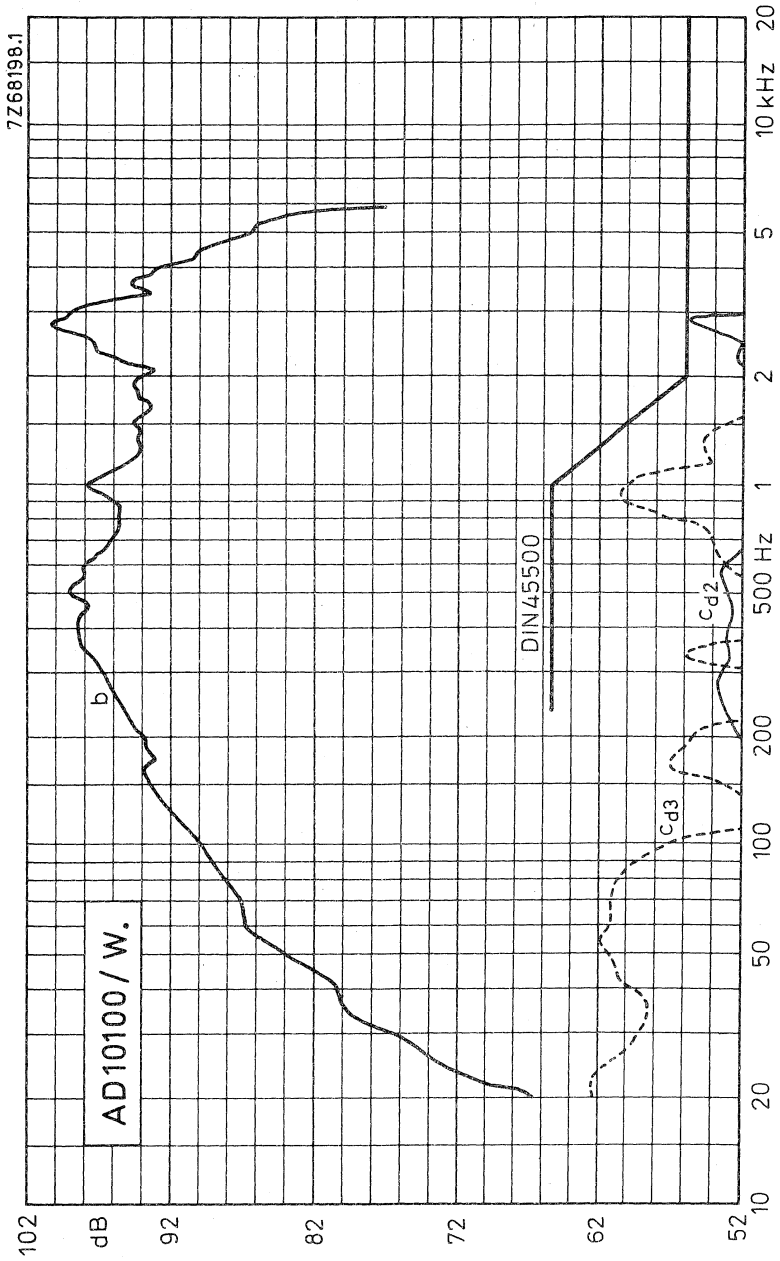

Fig. 2



12 inch HIGH POWER FULL RANGE LOUDSPEAKER

APPLICATION

Public address systems.

TECHNICAL DATA

	version			
	M4	M8	M15	
Rated impedance	4	8	15	Ω
Voice coil resistance	3,4	7	13	Ω
Resonance frequency	45	45	45	Hz
Power handling capacity, measured without filter, loudspeaker unmounted	20	20	20	W
Operating power	1,44	1,44	1,44	W
Sweep voltage	6,3	9	12,2	V
Energy in airgap	225	225	225	mJ
Flux density	1,12	1,12	1,12	T
Airgap height	5	5	5	mm
Voice coil height	6,5	6,5	4,5	mm
Core diameter	25	25	25	mm
Magnet material	Fxd	Fxd	Fxd	
diameter	90	90	90	mm
weight	0,45	0,45	0,45	kg
Weight of loudspeaker	1,8	1,8	1,8	kg

The loudspeaker has a paper surround and a double cone.

Connection to the loudspeaker by means of 6,3 mm (0,25 inch) Fastons or soldering.

Dimensions (mm)

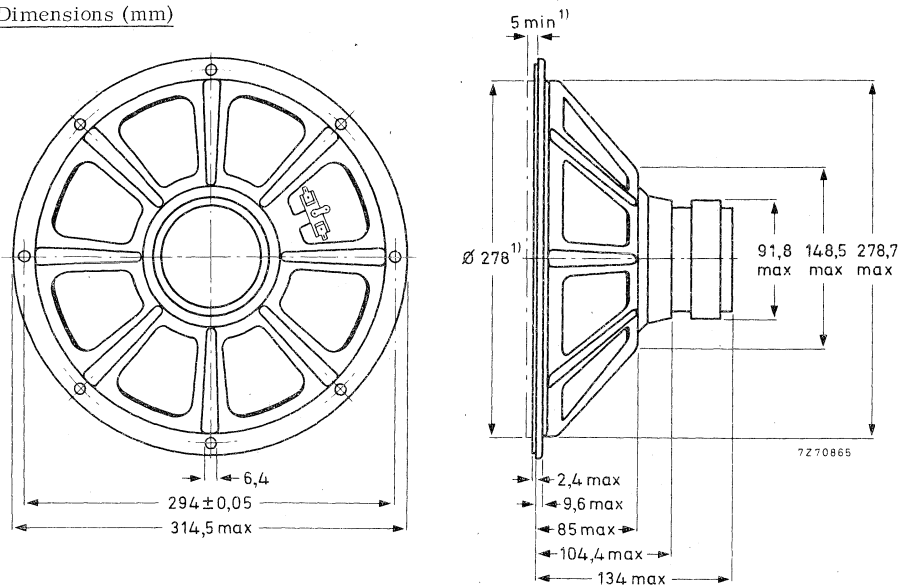

Fig. 1

¹⁾ Baffle hole and clearance depth required for cone movement at the specified power handling capacity.

One tag is indicated by a red mark for in-phase connection.

AVAILABLE VERSIONS

AD1265/M4, catalogue number 2422 257 411.1

AD1265/M8, catalogue number 2422 257 411.2

AD1265/M15, catalogue number 2422 257 411.3

(0 = stamped on loudspeaker magnet, not to be used for ordering)

2 = for bulk packing *)

6 = for single unit packing

FREQUENCY RESPONSE CURVES (see Fig. 2)

Curve b : Sound pressure measured in anechoic room at operating power of 1,44 W.
Loudspeaker mounted in sealed 80 l enclosure, filled with 1 kg of glass wool.

Curve c : 2nd and 3rd harmonic distortion, measured at operating power of 1,44 W in anechoic room. Loudspeaker mounted in sealed 80 l enclosure, filled with 1 kg of glass wool.

*) Minimum packing quantity 1 per unit.

12 inch HIGH POWER FULL RANGE
LOUDSPEAKER

AD1265/M.

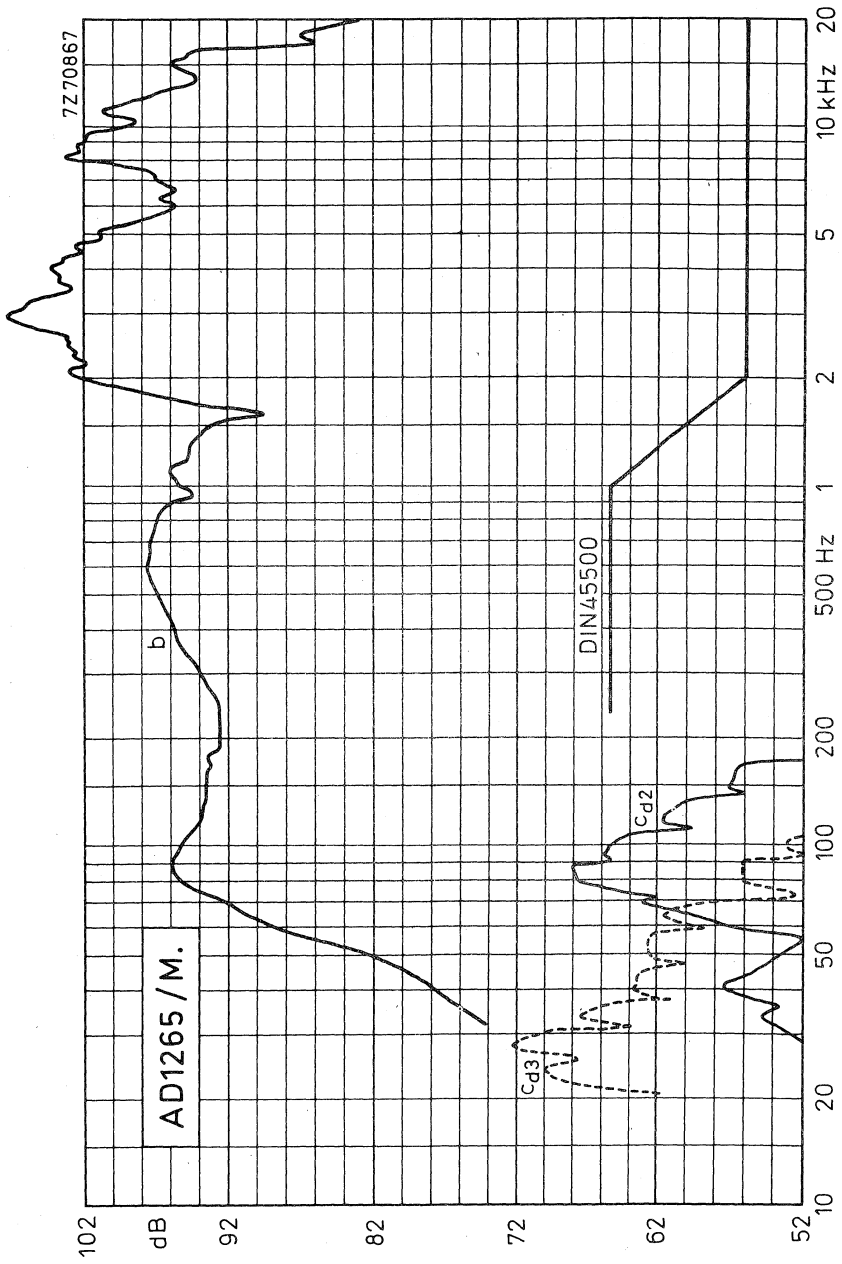

Fig. 2



12 inch HIGH POWER WOOFER LOUDSPEAKER

APPLICATION

For high fidelity reproduction in sealed acoustic enclosures in accordance with DIN45500. Maximum enclosure volume 80 litres. Maximum recommended cross-over frequency 800 Hz. Rated frequency range 40 to 3000 Hz.

TECHNICAL DATA

	version		
	W4	W8	
Rated impedance	4	8	Ω
Voice coil resistance	3,2	6,8	Ω
Resonance frequency	20	20	Hz
Power handling capacity, measured without filter, mounted in 80 l sealed enclosure	30	30	W
Operating power	4,5	4,5	W
Sweep voltage	5	7	V
Energy in airgap	280	280	mJ
Flux density	0,94	0,94	T
Airgap height	5	5	mm
Voice coil height	12,1	13,5	mm
Core diameter	25	25	mm
Magnet material	Fxd	Fxd	
diameter	90	90	mm
weight	0,45	0,45	kg
Weight of loudspeaker	1,8	1,8	kg

The loudspeaker has a rubber surround.

Connection to the loudspeaker by means of 6.3 mm(0,25 inch) Fastons or soldering.

Dimensions (mm)

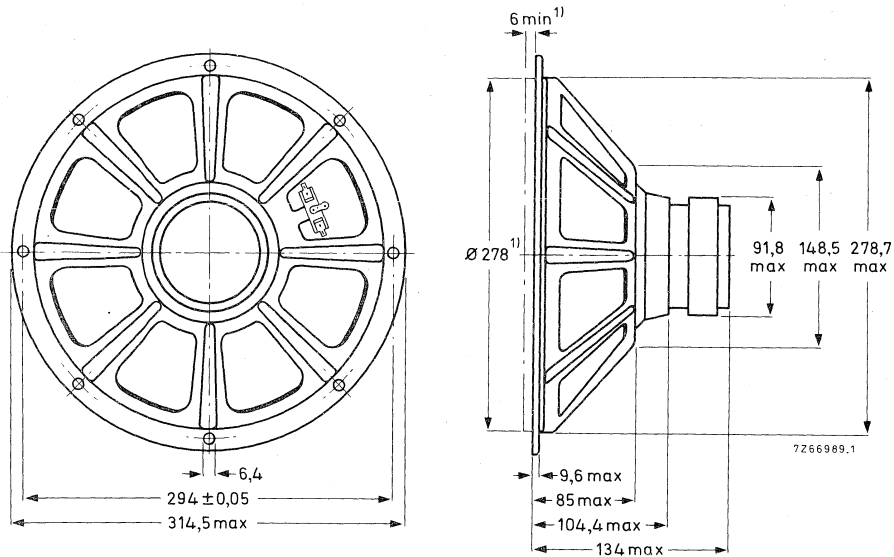

Fig. 1

1) Baffle hole and clearance depth required for cone movement at the specified power handling capacity.

One tag is indicated by a red mark for in-phase connection.

AVAILABLE VERSIONS

AD 1265/W4, catalogue number 2422 257 312.1

AD 1265/W8, catalogue number 2422 257 312.2

(0 = stamped on loudspeaker magnet,
not to be used for ordering)

2 for bulk packing*)

6 for single unit packing

FREQUENCY RESPONSE CURVES (see Fig. 2)

Curve b : Sound pressure measured in anechoic room at operating power of 4,5 W.
Loudspeaker mounted in sealed 80 l enclosure, filled with 1 kg of glass wool.

Curve c : 2nd and 3rd harmonic distortion, measured at operating power of 4,5 W in anechoic room. Loudspeaker mounted in sealed 80 l enclosure, filled with 1 kg of glass wool. Baffle dimensions 500 x 600 mm.

*) Minimum packing quantity 1 per unit.

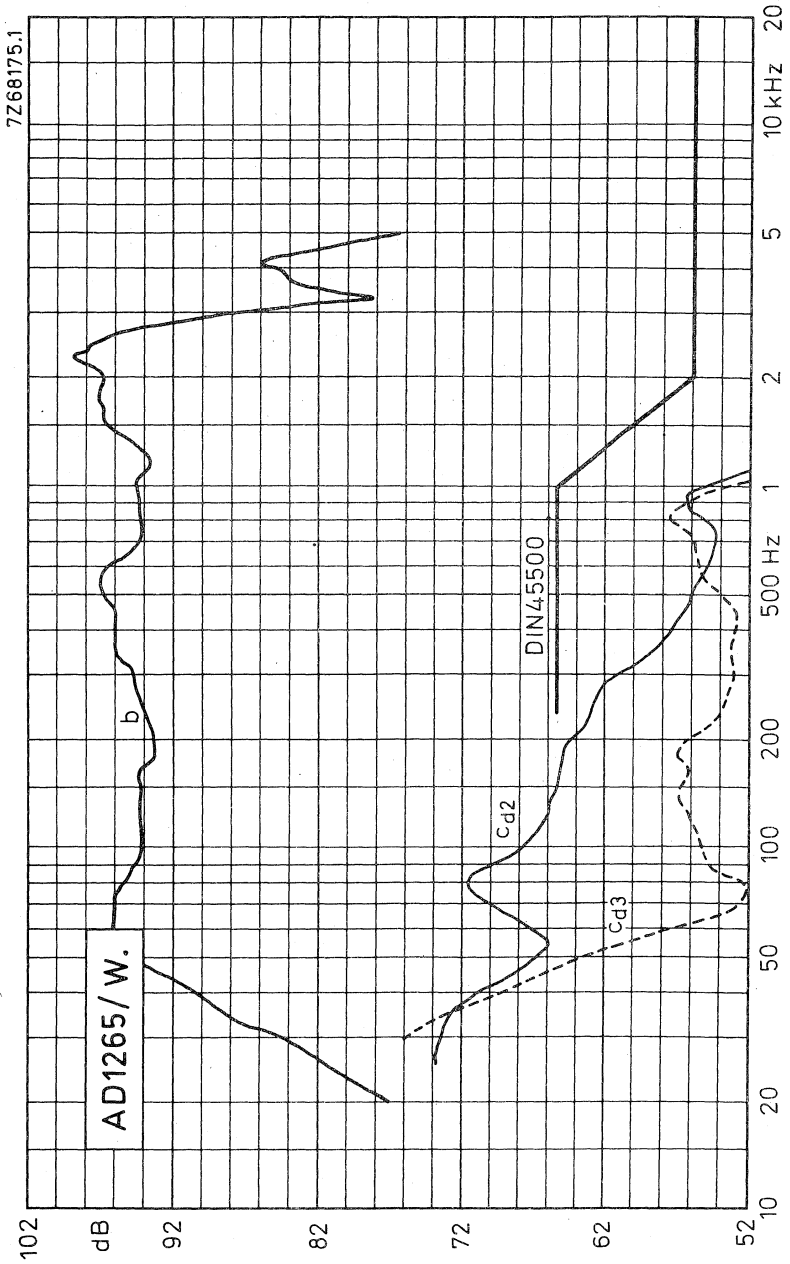

Fig. 2



12 inch HIGH POWER FULL RANGE LOUDSPEAKER

APPLICATION

A dual cone loudspeaker for high power applications such as guitar amplifiers and electronic organs.

TECHNICAL DATA

	version		
	HP4	HP8	
Rated impedance	4	8	Ω
Voice coil resistance	3,5	7,2	Ω
Resonance frequency	60	60	Hz
Power handling capacity, measured without filter loudspeaker unmounted	50	50	W
Operating power	1	1	W
Sweep voltage	10	14	V
Energy in airgap	820	820	mJ
Flux density	1,03	1,03	T
Airgap height	8	8	mm
Voice coil height	12,2	12,5	mm
Core diameter	50	50	mm
Magnet material	Fxd	Fxd	
diameter	130	130	mm
weight	1	1	kg
Weight of loudspeaker	3,27	3,27	kg

The loudspeaker has a textile surround and a cork gasket on the flange.

Connection to the loudspeaker by means of 6,3 mm (0,25 inch) Fastons or soldering.

Dimensions (mm)

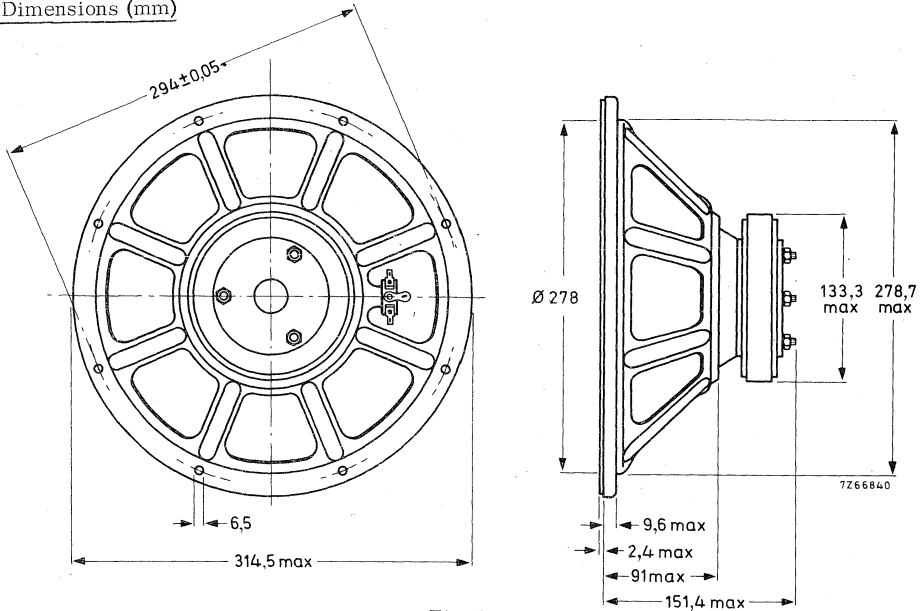

Fig. 1

Baffle hole diameter 278 mm

One tag is indicated by a red mark for in-phase connection.

AVAILABLE VERSIONS

- AD 12100/HP4, catalogue number 2422 257 511, 1
 - AD 12100/HP8, catalogue number 2422 257 511, 2
- (0 = stamped on loudspeaker magnet, not to be used for ordering)
- 2 for bulk packing*)
 - 6 for single unit packing

FREQUENCY RESPONSE CURVES (see Fig. 2)

Curve b : Sound pressure measured in anechoic room at operating power of 1 W.
Loudspeaker mounted in sealed 80 l enclosure, filled with 1 kg of glass wool.

Curve c : 2nd and 3rd harmonic distortion, measured at operating power of 1 W in anechoic room. Loudspeaker mounted in 80 l enclosure, filled with 1 kg of glass wool.

*) Minimum packing quantity 1 per unit.

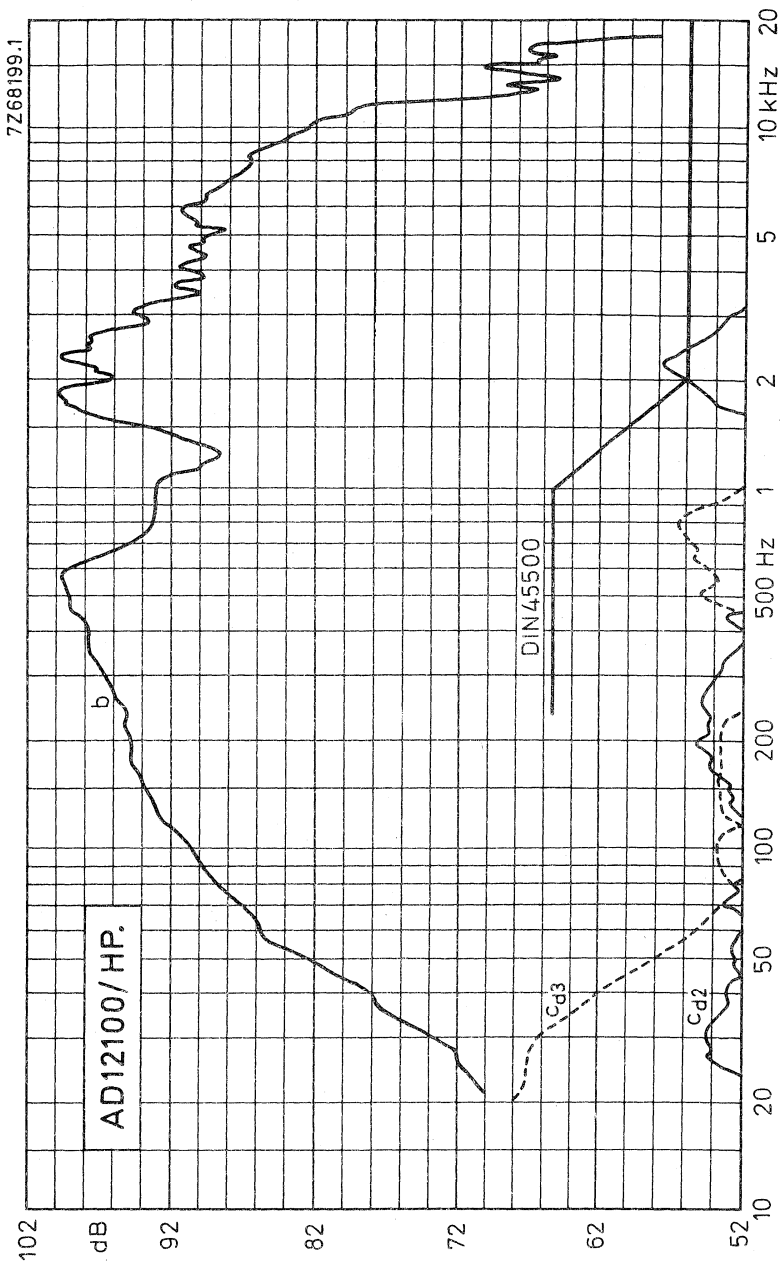

Fig. 2



12 inch HIGH POWER FULL RANGE LOUDSPEAKER

APPLICATION

A dual-cone loudspeaker with extremely high sensitivity for power applications such as public address systems, discotheques and domestic enclosures greater than 50 litres, and open baffles.

TECHNICAL DATA

	version			
	M4	M8	M15	
Rated impedance	4	8	15	Ω
Voice coil resistance	3,2	7	13,2	Ω
Resonance frequency	45	45	45	Hz
Power handling capacity, measured without filter, loudspeaker unmounted	25	25	25	W
Operating power	0,55	0,55	0,6	W
Sweep voltage	6,3	9	12,2	V
Energy in airgap	970	970	970	mJ
Flux density	1,15	1,15	1,15	T
Airgap height	8	8	8	mm
Voice coil height	9,1	10,3	13,3	mm
Core diameter	33,4	33,4	33,4	mm
Magnet material	Fxd	Fxd	Fxd	
diameter	130	130	130	mm
weight	1	1	1	kg
Weight of loudspeaker	3,3	3,3	3,3	kg

The loudspeaker has a paper surround and a cork gasket on the flange.

Connection to the loudspeaker by means of 6,3 mm (0,25 inch) Fastons or soldering.

Dimensions (mm)

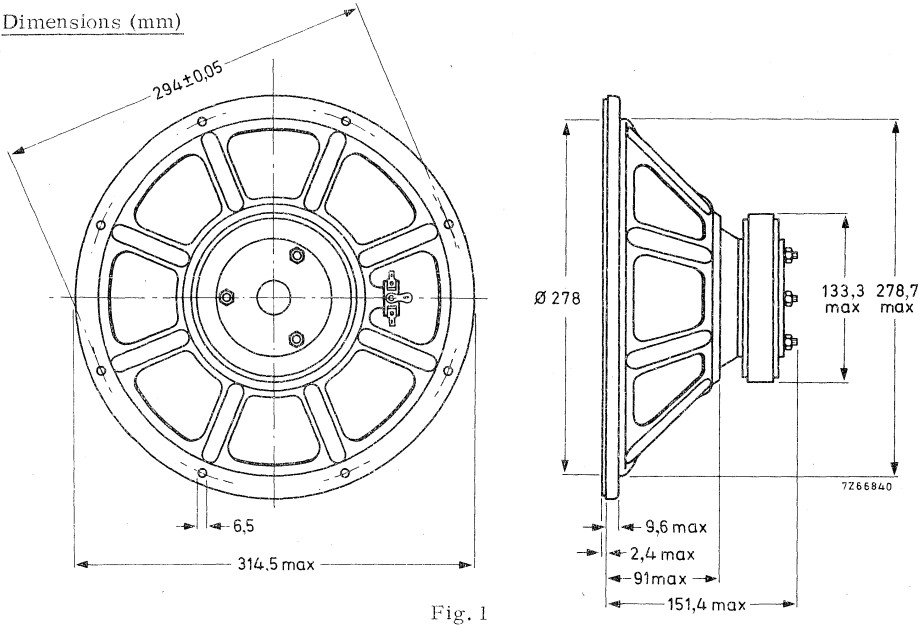

Fig. 1

Baffle hole diameter 278 mm

One tag is indicated by a red mark for in-phase connection.

AVAILABLE VERSIONS

AD 12100/M4. catalogue number 2422 257 510.1

AD 12100/M8. catalogue number 2422 257 510.2

AD 12100/M15. catalogue number 2422 257 510.3

(0 = stamped on loudspeaker magnet,
not to be used for ordering)

— 2 for bulk packing*)

— 6 for single unit packing

FREQUENCY RESPONSE CURVES (see Fig. 2)

Curve b : Sound pressure measured in anechoic room at operating power of 0,55 W.

Loudspeaker mounted in sealed 80 l enclosure, filled with 1 kg of glass wool.

Curve c : 2nd and 3rd harmonic distortion, measured at operating power of 0,55 W in anechoic room. Loudspeaker mounted in 80 l enclosure, filled with 1 kg of glass wool.

*) Minimum packing quantity 1 per unit.

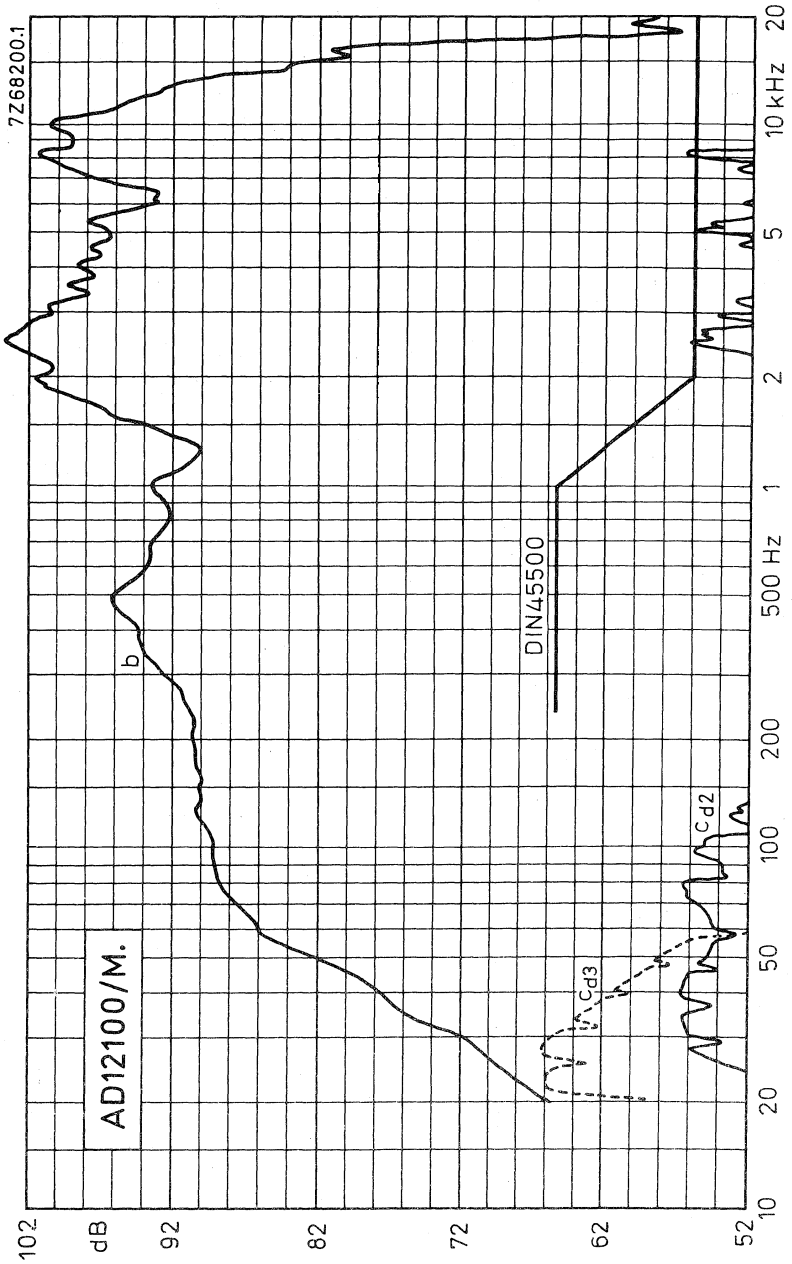

Fig. 2



12 inch HIGH POWER WOOFER LOUDSPEAKER

APPLICATION

For high fidelity reproduction in sealed acoustic enclosures in accordance with DIN45500. Recommended enclosure volume 80 litres. Maximum recommended cross-over frequency 700 Hz. Rated frequency range 30 to 700 Hz.

TECHNICAL DATA

	version		
	W4	W8	
Rated impedance	4	8	Ω
Voice coil resistance	3,4	6,5	Ω
Resonance frequency	19	19	Hz
Power handling capacity, measured without filter, mounted in 80 l sealed enclosure	40	40	W
Operating power	2	2	W
Sweep voltage	5	7	V
Energy in airgap	820	820	mJ
Flux density	1,03	1,03	T
Airgap height	8	8	mm
Voice coil height	15	17,2	mm
Core diameter	50	50	mm
Magnet material	Fxd	Fxd	
diameter	130	130	mm
weight	1,05	1,05	kg
Weight of loudspeaker	3,2	3,2	kg

The loudspeaker has a rubber surround.

Connection to the loudspeaker by means of 6,3 mm (0,25 inch) Fastons or soldering.

Dimensions (mm)

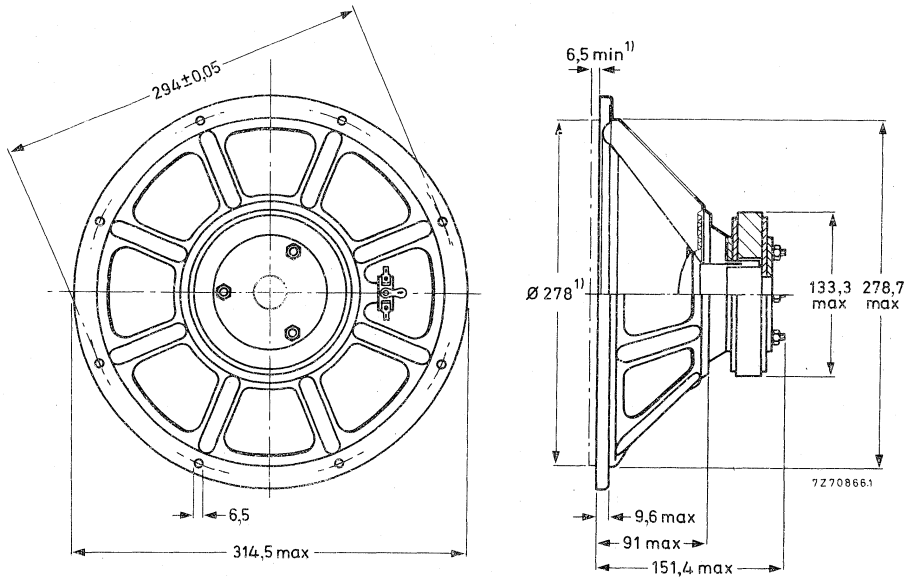

Fig. 1

1) Baffle hole and clearance depth required for cone movement at the specified power handling capacity.

One tag is indicated by a red mark for in-phase connection.

AVAILABLE VERSIONS

AD 12100/W4, catalogue number 2422 257 413.1

AD 12100/W8, catalogue number 2422 257 413.2

- (0 = stamped on loudspeaker magnet, not to be used for ordering)
- 2 for bulk packing*)
- 6 for single unit packing

FREQUENCY RESPONSE CURVES (see Fig. 2)

Curve b : Sound pressure measured in anechoic room at operating power of 2 W.
Loudspeaker mounted in sealed 80 l enclosure, filled with 1 kg of glass wool.

Curve c : 2nd and 3rd harmonic distortion, measured at operating power of 2 W in anechoic room. Loudspeaker mounted in 80 l enclosure, filled with 1 kg of glass wool.

*) Minimum packing quantity 1 per unit.

12 inch HIGH POWER WOOFER
LOUDSPEAKER

AD12100/W.

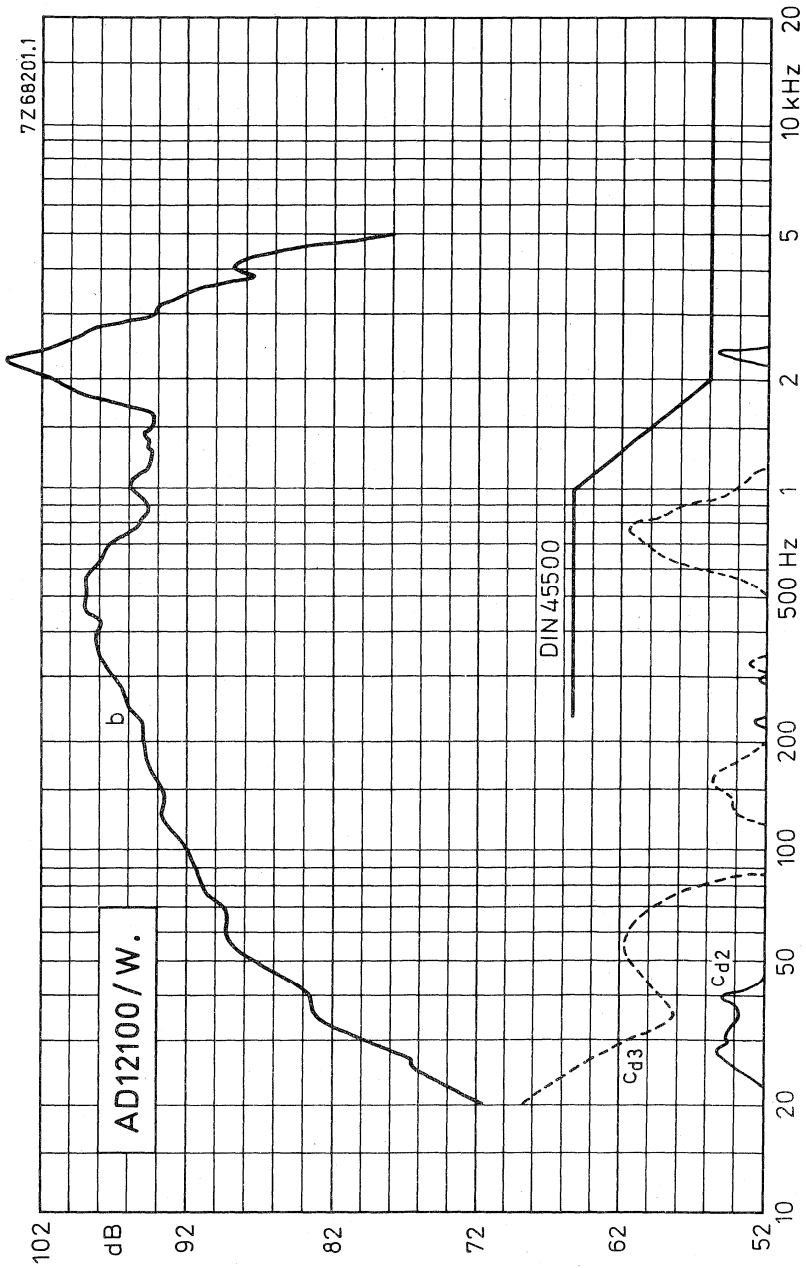

Fig. 2



Cross-over networks



2-WAY CROSS-OVER NETWORK

APPLICATION

For use in 2-way loudspeaker systems with High fidelity or High quality woofers and the dome tweeter AD0160/T.

TECHNICAL DATA

Rated impedance			
type ADF1600/4	4	Ω	
type ADF1600/8	8	Ω	
Cross-over frequency			
type ADF1600/4	1600	Hz	
type ADF1600/8	1800	Hz	
Power handling capacity	20	W	
Slope, low pass	6	dB/octave	
high pass	12	dB/octave	

Circuit diagram

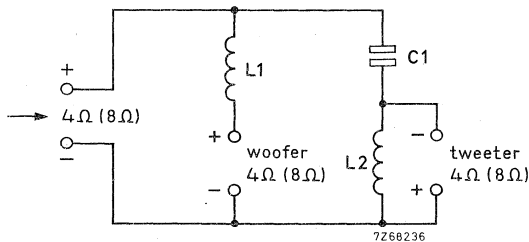

	version		
	4 Ω	8 Ω	
L1	0,8	0,8	mH
L2	0,35	0,5	mH
C1	12	8	μ F

Loudspeaker terminal marked with red dot to be connected to +.

Frequency characteristics

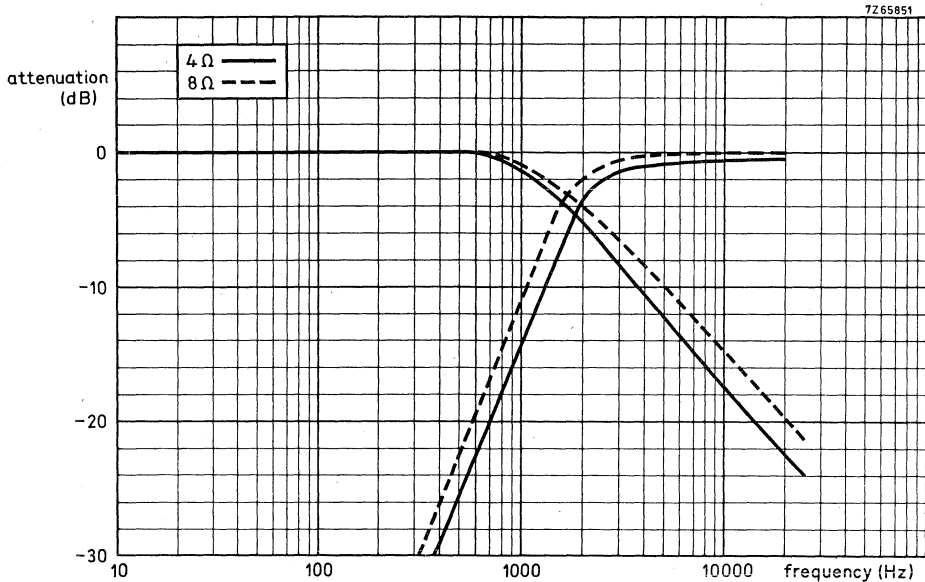

Dimensions (mm)

Total height 42 mm
 6 soldering tags for connection

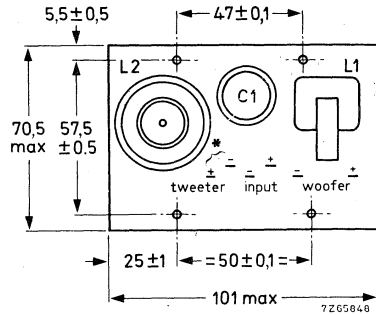

* Attention : If the + and - signs printed on the board do not correspond with their respective positions in the drawing, the connections must be made in accordance with the drawing.

CATALOGUE NUMBERS

Type ADF1600/4: catalogue number 4304 078 72720
 Type ADF1600/8: catalogue number 4304 078 72820

2-WAY CROSS-OVER NETWORK

APPLICATION

For use in 2-way loudspeaker systems with High fidelity or high quality woofers and cone tweeters AD2071/T. or AD2090/T.

TECHNICAL DATA

Rated impedance		
type ADF2400/4	4	Ω
type ADF2400/8	8	Ω
Cross-over frequency	2400	Hz
Power handling capacity	20	W
Slope, low pass	6	dB/octave
high pass	6	dB/octave

Circuit diagram

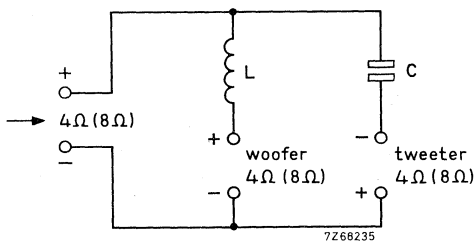

	version		
	4 Ω	8 Ω	
L	0,5	1	mH
C	12	5	μ F

Loudspeaker terminal marked with red dot to be connected to +.

Frequency characteristic

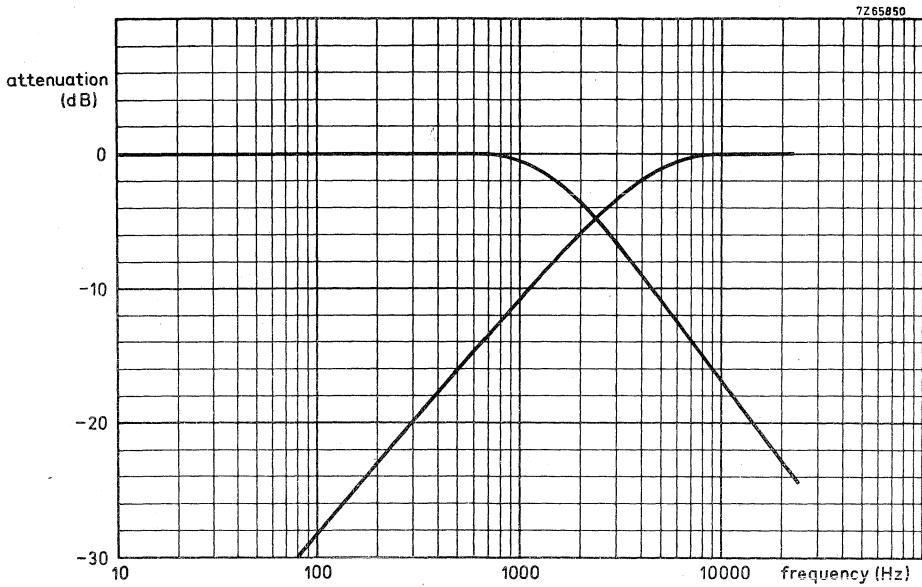

Dimensions (mm)

Total height 42 mm
6 soldering tags for connection

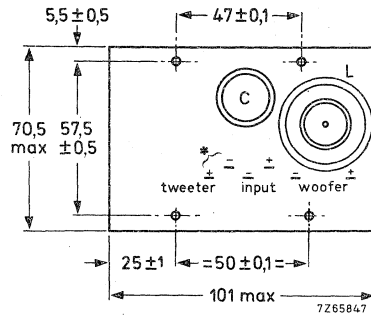

* Attention : If the + and - signs printed on the board do not correspond with their respective positions in the drawing, the connections must be made in accordance with the drawing.

CATALOGUE NUMBERS

Type ADF2400/4: catalogue number 4304 078 72860
Type ADF2400/8: catalogue number 4304 078 72850

3-WAY CROSS-OVER NETWORK

APPLICATION

For use in 3-way loudspeaker systems with High fidelity or High quality woofers, squawkers and dome tweeters.

TECHNICAL DATA

Rated impedance,		
type ADF500/4500/4	4	Ω
type ADF500/4500/8	8	Ω
Cross-over frequencies	500 and 4500	Hz
Power handling capacity	40	W
Slope, low pass	6	dB/octave
band pass (mid range)	6	dB/octave
high pass	12	dB/octave

Circuit diagram

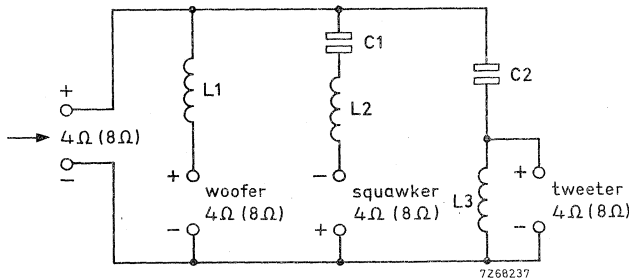

	version		
	4 Ω	8 Ω	
L1	2, 1	3	mH
L2	0, 2	0, 35	mH
L3	0, 2	0, 5	mH
C1	50	24	μ F
C2	5	3, 3	μ F

Loudspeaker terminal marked with red dot to be connected to +.

Frequency characteristics

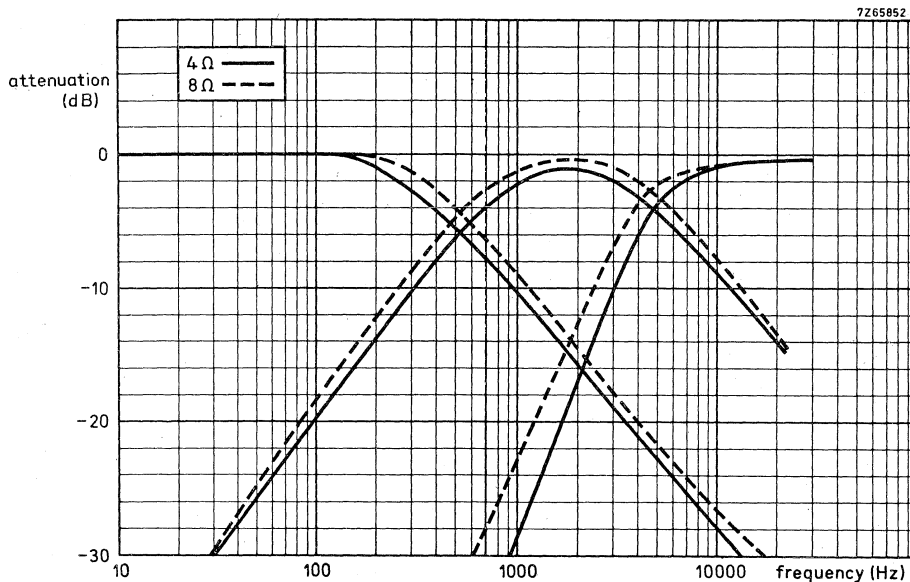

Dimensions (mm)

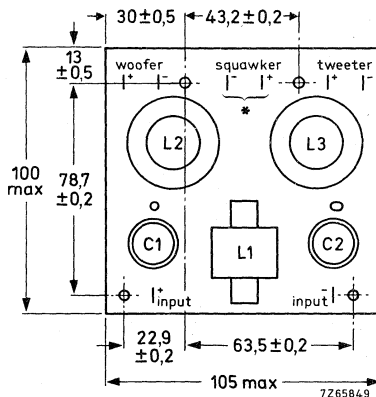

Total height 42 mm
Connections with 0,25 inch Fastons

* Attention : If the + and - signs printed on the board do not correspond with their respective positions in the drawing, the connections must be made in accordance with the drawing.

CATALOGUE NUMBERS

Type ADF500/4500/4: catalogue number 4304 078 72840
Type ADF500/4500/8: catalogue number 4304 078 72500

Recommended
loudspeaker combinations





RECOMMENDED LOUDSPEAKER COMBINATIONS

4 and 8 Ω impedance

COMBINATION							enclosure volume	power handling capacity
no.	woofer	squawker	tweeter	cross-over-network	enclosure volume	power handling capacity		
1	AD 5060/W 4 (8)	-	AD 2071/T 4 (8)	ADF 2400/4 (8)	3 1	10 W		
2	AD 5060/W 4 (8)	-	AD 0140/T 4 (8)	ADF 1600/4 (8)	3 1	10 W		
3	AD 7066/W 4 (8)	-	AD 0140/T 4 (8)	ADF 1600/4 (8)	7 1	20 W		
4	AD 8061/W 4 (8)	-	AD 0140/T 4 (8)	ADF 1600/4 (8)	20 1	20 W		
5	AD 8066/W 4 (8)	-	AD 0140/T 4 (8)	ADF 1600/4 (8)	20 1	20 W		
6	AD 8061/W 4 (8)	AD 5060/Sq 4 (8)	AD 0140/T 4 (8)	ADF 500/4500/4 (8)	25 1	40 W		
7	AD 8066/W 4 (8)	AD 5060/Sq 4 (8)	AD 0140/T 4 (8)	ADF 500/4500/4 (8)	25 1	40 W		
8	AD 10100/W 4 (8)	AD 5060/Sq 4 (8)	AD 0140/T 4 (8)	ADF 500/4500/4 (8)	35 1	40 W		
9	AD 10100/W 4 (8)	2 x AD 5060/Sq 8 (4)	2 x AD 0140/T 8 (4)	ADF 500/4500/4 (8)	40 1	40 W		
10	AD 1265/W 4 (8)	2 x AD 5060/Sq 8 (4)	2 x AD 0140/T 8 (4)	ADF 500/4500/4 (8)	50 1	40 W		
11	AD 12100/W 4 (8)	4 x AD 5060/Sq 4 (8)	4 x AD 0140/T 4 (8)	ADF 500/4500/4 (8)	80 1	40 W		

RECOMMENDED LOUDSPEAKER COMBINATIONS

For more information see our Application book "Building Hi-Fi speaker systems".

Television tuners
and aerial input assemblies



V.H.F. TELEVISION TUNER

with diode tuning

QUICK REFERENCE DATA			
Systems	C. C. I. R. systems A, B and I		
Channels	<u>system A</u>	<u>system B</u>	<u>system I</u>
band I	B1 to B5	E2 to E4	IA to IC
band III	B6 to B14	E5 to E12	ID to IJ
Intermediate frequencies			
picture	34,65 MHz	38,9 MHz	39,5 MHz
sound	38,15 MHz	33,4 MHz	33,5 MHz

APPLICATION

Designed to cover 405 line v.h.f. and 625 line (wired distribution) channels, and the v.h.f. channels of C. C. I. R. system B.

DESCRIPTION

The ELC1042/05 is a v.h.f. tuner with electronic tuning and band switching, covering the v.h.f. band I (frequency range 41,5 to 68 MHz), and the v.h.f. band III (frequency range 174 to 230 MHz).

Mechanically the tuner is built on a low-loss printed-wiring board, carrying all components in a metal housing made of a rectangular frame and front and rear cover (see Fig.2). The aerial connection is on the frame side, all other connections (supply voltages, a.g.c. voltage, tuning and switching voltages) are made via feedthrough capacitors in the underside. The mounting method is shown in Figs.3 and 4.

The v.h.f. aerial signal is fed via an i.f. trap to a tuned input circuit, which is connected to the emitter of the input transistor BF264. The collector load of this transistor is formed by a double tuned circuit, transferring the signal to the base of the mixer transistor BF195. The oscillator is equipped with a BF194 transistor. The three r.f. circuits are tuned by three capacitance diodes BB105G. Switching between v.h.f. I and III is achieved by five switching diodes BA182.

The collector circuit of the mixer transistor is a single tuned i.f. resonant circuit, at the low end of which the i.f. signal is capacitively coupled out of the tuner.

The tuner requires transistor supply voltages of +12 V, a switching voltage of +12 V, a.g.c. voltages, variable from +2,5 V (normal operating point) to about +6 V (maximum a.g.c.) and a tuning voltage, variable from +0,3 V to +25 V.

The aerial input of the tuner is asymmetrical. For use in symmetrical aerial systems, aerial transformers (baluns) are available (see ACCESSORIES).

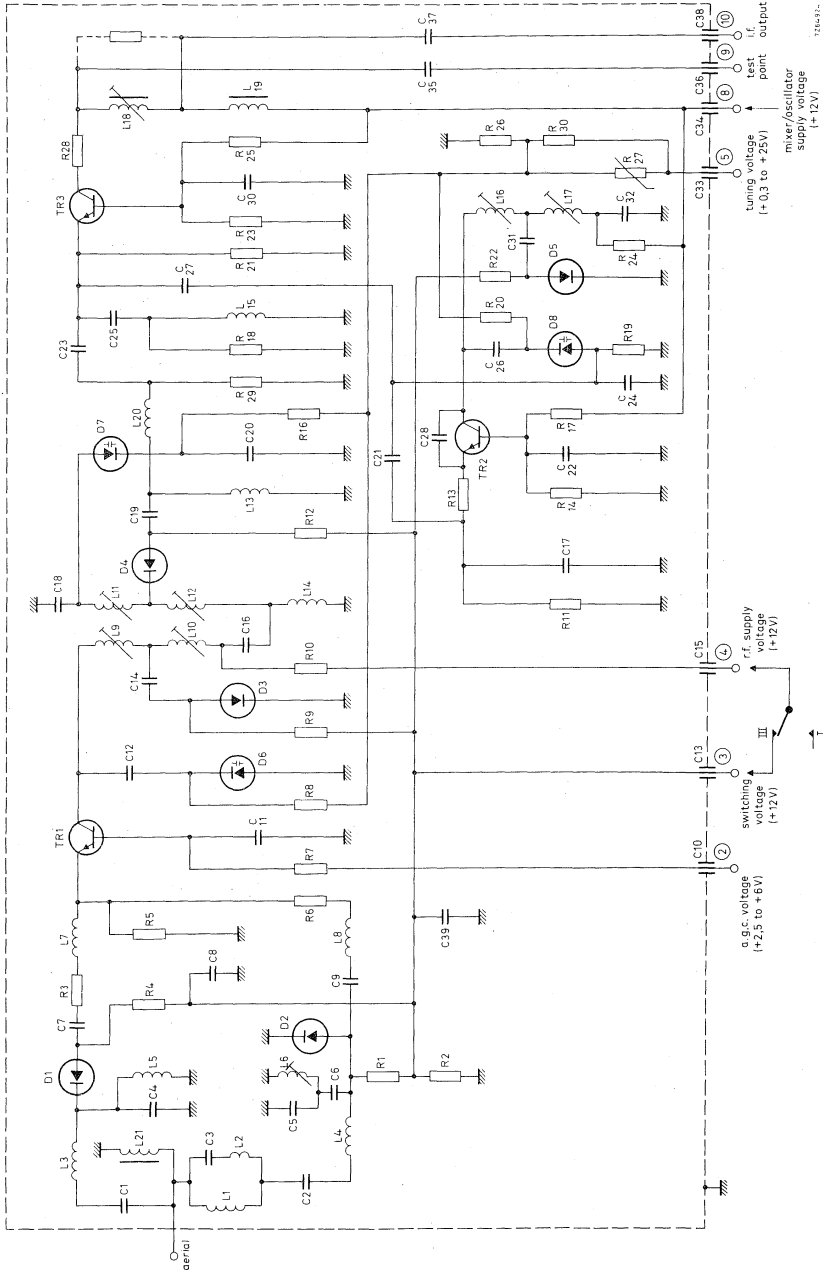

Fig. 1.



MECHANICAL DATA

Dimensions in mm

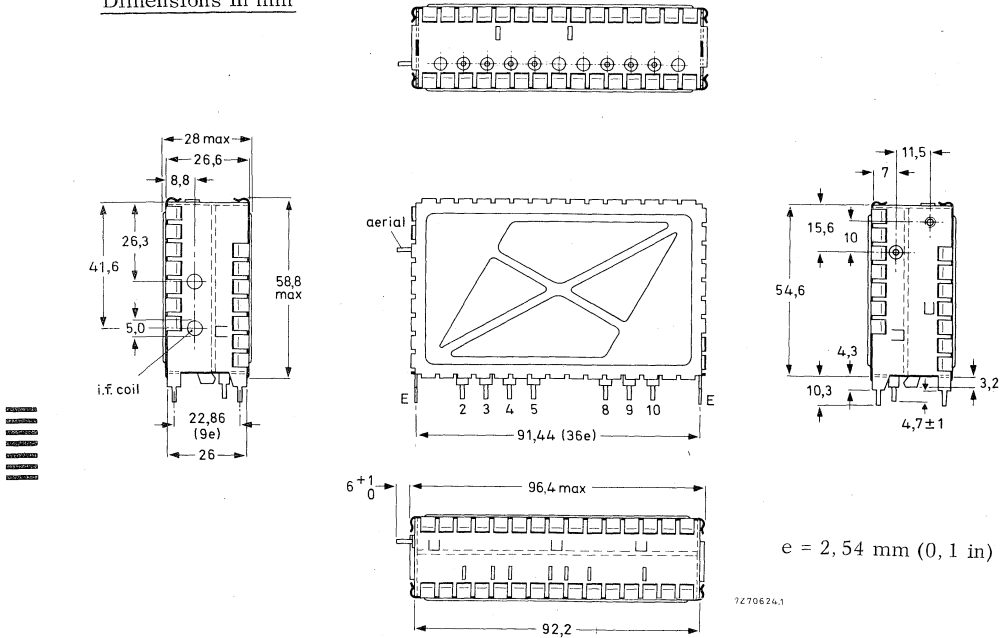

Fig. 2

- Terminal 2 = a. g. c. voltage, +2,5 to +6,0 V
- 3 = switching voltage, v. h. f. III, +12 V (approx. 12,5 mA)
- 4 = r. f. supply voltage, +12 V (approx. 3,2 to 10 mA)
- 5 = tuning voltage, +0,3 to +25 V
- 8 = mixer/oscillator supply voltage, +12 V (approx. 6,7 mA)
- 9 = test point
- 10 = i. f. output
- E = earth

Mounting

The tuner may be mounted by soldering it on to a printed-wiring board, using the piercing diagram shown in Fig. 3. (The tuner may also be mounted by means of a snap-in mount or a bracket. Information will be supplied upon request).

The tuner may be mounted anywhere in the receiver and there are no restrictions on orientation.

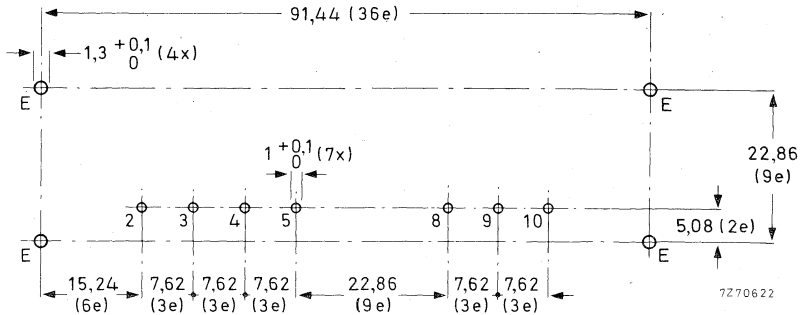

Fig. 3 Piercing diagram viewed from solder side of board; e = 2,54 mm (0,1 in)

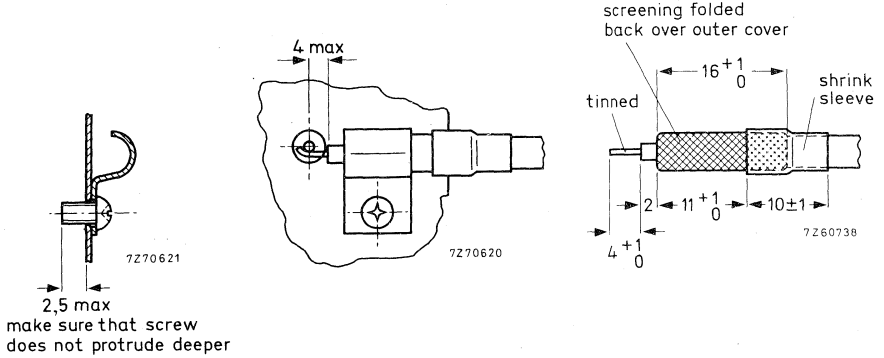

Fig. 4 Recommended fixing method of the aerial cable. Use a self-tapping screw.

ELECTRICAL DATA

Unless otherwise specified all electrical values apply at an ambient temperature of 25 ± 5 °C and a supply voltage of $12 \pm 0,3$ V.

Semiconductors, r. f. amplifier		BF264	
mixer		BF195	
oscillator		BF194	
tuning diodes		3 x BB105G	
switching diodes		5 x BA182	
Ambient temperature range			
operating		+5 to +55 °C	
storage		-25 to +85 °C	
Supply voltage		+12 V \pm 10%	
Current drawn from +12 V supply			
band I		10 to 16,5 mA	} depending on } a. g. c. voltage
band III		22,5 to 29 mA	
A. G. C. voltage (Figs. 5 and 6)			
band I, at nominal gain		+2,5 V	
at 40 dB gain reduction		+4,9 V (typical)	
band III, at nominal gain		+2,5 V	
at 40 dB gain reduction		+4,3 V (typical)	
A. G. C. current at 40 dB gain reduction			
band I		max. 0,8 mA	
band III		max. 0,6 mA	
Tuning voltage range (Figs. 7 and 8)		+0,3 to +25 V	
Current drawn from 25 V tuning voltage supply		max. 30 μ A	
Switching voltage			
band I		open circuit	
band III		+12 V, \pm 10%	
Frequency ranges	<u>system A</u>	<u>system B</u>	<u>system I</u>
band I	channel B1 (picture carrier 45 MHz) to channel B5 (picture carrier 66,75 MHz)	channel E2 (p. c. 48,25 MHz) to channel E4 (p. c. 62,25 MHz)	channel IA (p. c. 45,75 MHz) to channel IC (p. c. 61,75 MHz)
band III	channel B6 (picture carrier 179,75 MHz) to channel B14 (picture carrier 219,75 MHz)	channel E5 (p. c. 175,25 MHz) to channel E12 (p. c. 224,25 MHz)	channel ID (p. c. 175,25 MHz) to channel IJ (p. c. 215,25 MHz)
Intermediate frequencies			
picture	34,65 MHz	38,9 MHz	39,5 MHz
sound	38,15 MHz	33,4 MHz	33,5 MHz

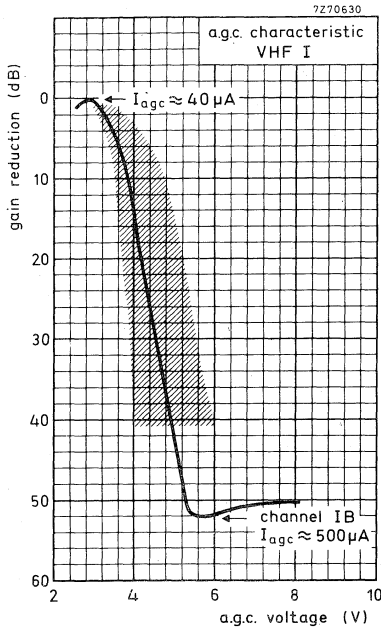

Fig. 5.

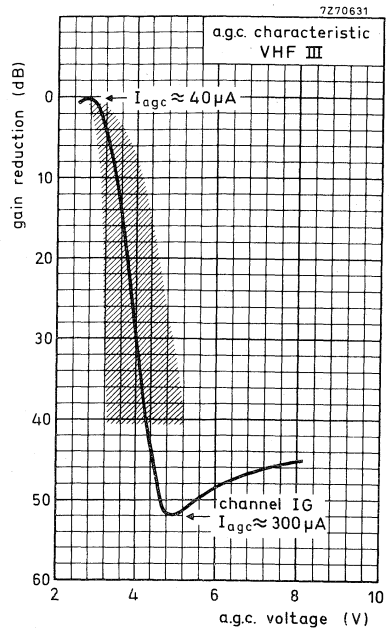

Fig. 6.

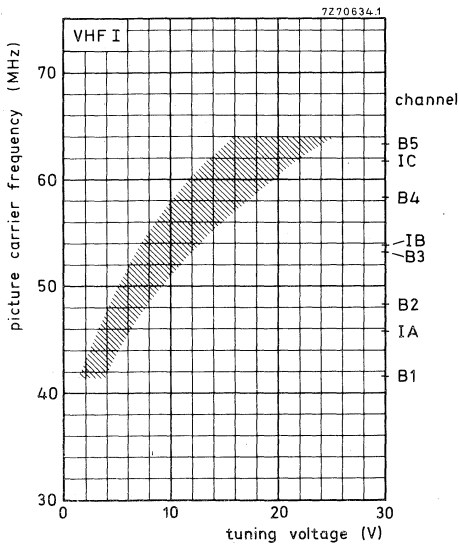

Fig. 7.

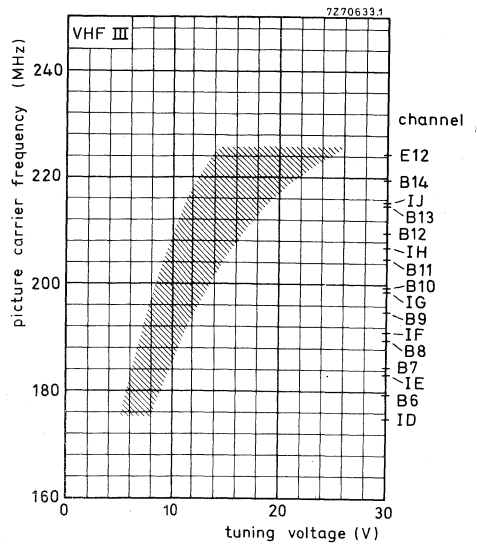

Fig. 8.

Input impedance	75 Ω	
asymmetrical	300 Ω (see ACCESSORIES)	
symmetrical		
V. S. W. R. (between picture carrier and sound carrier)	v. s. w. r. at nom. gain	max. v. s. w. r. during gain control
band I (except channel B1)	max. 3,5	max. 3,5
band III	max. 3,5	max. 3,5
A. G. C. range		
band I		min. 40 dB
band III		min. 40 dB
R. F. curves		
bandwidth, band I, except channel B1		typ. 10 to 12 MHz
band III		typ. 9 to 20 MHz
tilt, band I, except channel B1		max. 3 dB
band III, except channel E 12		max. 3 dB
Power gain (see also ADDITIONAL INFORMATION)		
band I, except channel B1		min. 18 dB
channel B1		min. 16 dB
channel IA		typ. 20 dB
channel IC		typ. 22 dB
band III		min. 18 dB
channel ID		typ. 25 dB
channel IJ		typ. 24 dB
Noise figure		
band I, except channel B1		max. 10 dB
channel IB		typ. 7,5 dB
band III		max. 10 dB
channel IG		typ. 7,0 dB
I. F. rejection		
band I, channel B2		min. 30 dB
channel B5		min. 40 dB
band III		min. 60 dB
Image rejection		
band I		min. 60 dB
band III		min. 40 dB

Signal handling (see also Figs. 9 and 10)

Minimum input signal (e. m. f.) producing
cross modulation (1%) at nominal gain,
in channel

(wanted signal: picture carrier frequency,
interfering signal: sound carrier
frequency), v. h. f. I
v. h. f. III

typ. 8 to 14 mV }
typ. 6 to 10 mV } Note 1

in band

(wanted signal: picture carrier frequency
of channel X,
interfering signal: picture carrier of
channel X-2

v. h. f. I
v. h. f. III

typ. 60 to 100 mV }
typ. 20 to 30 mV } Note 1

Minimum input signal (e. m. f.) producing
overloading, at nominal gain

v. h. f. I
v. h. f. III

typ. 20 mV }
typ. 13 mV } Note 2

at maximum a. g. c.

v. h. f. I
v. h. f. III

min. 200 mV }
min. 200 mV } Note 2

Minimum input signal (e. m. f.) at nominal
gain producing a shift of the oscillator
frequency of 20 kHz

typ. 20 to 50 mV (Note 3)

Detuning of the i. f. output circuit as a
result of bandswitching and tuning

max. 200 kHz

Shift of oscillator frequency

at a change of the supply voltage of 10%

band I
band III

max. 300 kHz
max. 300 kHz

during warm-up time (measured between 3 s
and 60 s after switching on)

band I
band III

max. 50 kHz
max. 50 kHz

Note 1 - This e. m. f. is referred to an impedance of 75 Ω .

1% cross modulation means that 1% of the modulation depth of the interfering
signal is transferred to the wanted signal.

Note 2 - This e. m. f. is referred to an impedance of 75 Ω .

Criterion of overloading: 30% compression of the synchronization pulses of a
standard television signal or a noticeable deterioration of the picture quality.

Note 3 - This e. m. f. is referred to an impedance of 75 Ω .

Drift of oscillator frequency
at a change of the ambient temperature
from 25 to 40 °C

band I

max. 400 kHz

band III

max. 400 kHz

Oscillator radiation (oscillator voltages at
the aerial terminal)

The oscillator radiation will be within the limits of BS905: 1969 provided no connection has been made to the test point and the circuit connected to the i. f. output is carefully shielded.

For the oscillator fundamentals use is made of the relaxed limits, assuming that the design of the i. f. amplifier of the receiver is such that a detuning of the oscillator of -2,0 MHz or +0,6 MHz from the nominal frequency will result in unacceptable picture and/or sound degradation.

Immunity from radiated interference

If the tuner, including the aerial connection (see Fig. 4) is installed in a professional manner, the immunity from radiated interference will be within the limits specified in BS905: 1969.

If a higher safety margin, or another cable connection is required, use can be made of an immunity shield (see ACCESSORIES).

Microphonics

If the tuner is installed in a professional manner, there will be no noticeable microphonics.

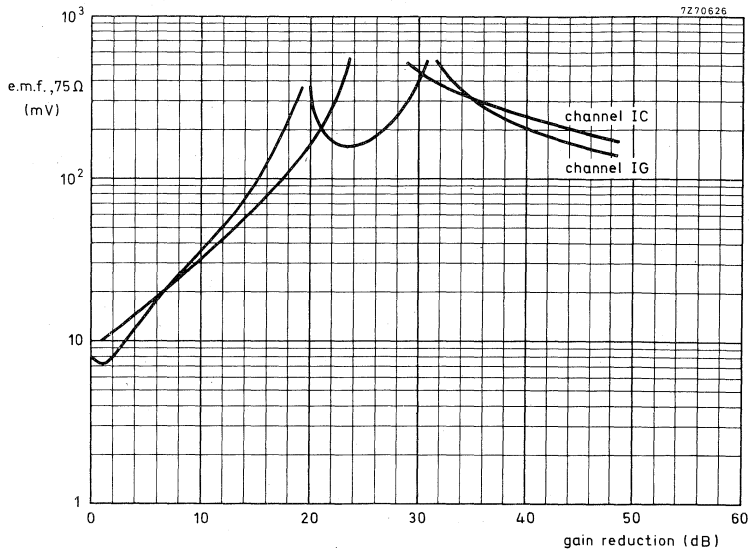

Fig. 9. Cross modulation, in channel.

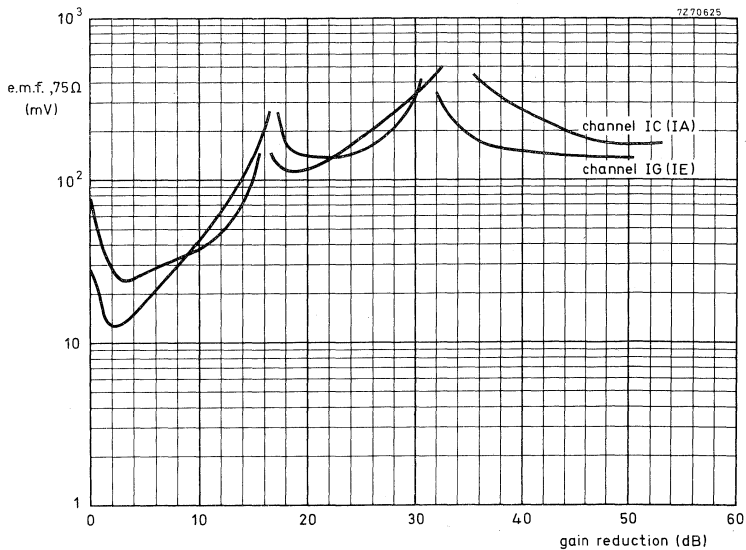

Fig. 10. Cross modulation, in band; the interfering channels are given between brackets.

ADDITIONAL INFORMATION

Measuring method of power gain

The i.f. output of the tuner should be terminated with the circuit given below, the test-point (terminal 9) not being connected.

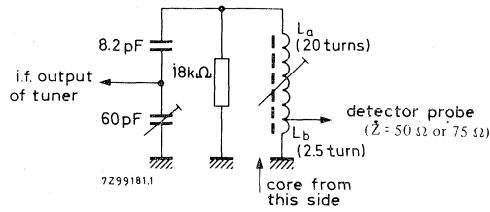

Fig. 11.

Feed an i.f. sweep signal to the v.h.f. i-mixer coupling coil.

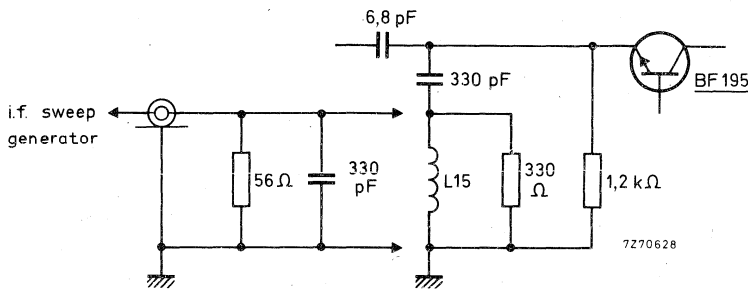

Fig. 12.

Adjust the trimmer (Fig. 11), tunable coil La/Lb, i.f. output coil of the tuner L18 (Fig. 1), and the coupling between La and Lb to get the resonant curve as given below.

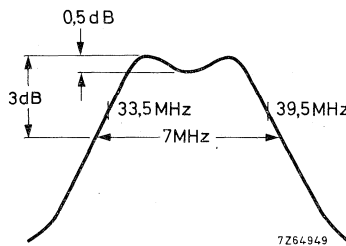

Fig. 13

Display the r. f. + i. f. curve of the tuner at 190 MHz (picture carrier frequency) and make, if necessary, small corrections in the alignment of the i. f. coils (L_a/L_b and L18) to get the markers 39,5 MHz and 33,5 MHz symmetrically on the slopes of the curve, and the peaks at equal amplitude.

Because the output impedance of the dummy circuit is 50 to 75 Ω , the power gain can be measured in the conventional manner by inserting tuner and dummy circuit between a 75 Ω source and a 75 Ω detector (or between a 50 Ω source and matching pad 50/75 Ω and a 50 Ω detector).

ACCESSORIES

Aerial input transformer ELC 1094, catalogue number 3122 107 10121, for converting the aerial input from 75 Ω asymmetric to 300 Ω symmetric.

Immunity shield for screening the aerial connection, consisting of:
shield, catalogue number 4313 132 01910
clamp, catalogue number 4313 132 01890

OTHER AVAILABLE VERSION

ELC1042 - catalogue number 2422 542 10421.

This tuner is identical with the ELC1042/05 except that the i. f. coil L18 of the ELC1042 has four additional turns.



U.H.F. TELEVISION TUNER

with diode tuning

QUICK REFERENCE DATA		
Systems	C.C.I.R systems G and I	
Channels	21 to 69	
Intermediate frequencies	<u>system G</u>	<u>system I</u>
picture	38,9 MHz	39,5 MHz
sound	33,4 MHz	33,5 MHz

APPLICATION

Designed to cover the u.h.f. channels 21 to 69 of C.C.I.R. systems G and I.



DESCRIPTION

The ELC1043/05 is an u. h. f. tuner with electronic tuning covering the u. h. f. bands IV and V (frequency range 470 to 860 MHz).

Mechanically the tuner is built on a low-loss printed-wiring board, carrying all components, in a metal housing made of a rectangular frame and front and rear cover (see Fig. 2). The aerial connection is on the frame side, all other connections (supply voltages, a. g. c. voltage and tuning voltage) are made via feedthrough capacitors in the under side. The mounting method is shown in Figs. 3 and 4.

The tuner is of the three transistor type, comprising two r. f. stages and an oscillator/mixer. The input circuit is untuned, so that optimum noise figures may be realised, whilst the additional r. f. stage compensates for the increased insertion loss associated with diode tuned circuits.

Coupling between the first and second r. f. stages is by a half-wave tuned line, between the second r. f. stage and the mixer is by bandpass half-wave tuned lines. The secondary of the bandpass is coupled to the emitter of the oscillator/mixer stage via a coupling loop, which also provides the inductive feedback of the oscillator.

Half-wave lines, terminated at one end by a fixed capacitor and tuned at the other end by a variable capacitance diode, are used throughout.

The tuner requires transistor supply voltages of +12 V, a. g. c. voltages, variable from +2,5 V (normal operating point) to about +7,5 V (maximum a. g. c.) and a tuning voltage, variable from +0,3 V to +25 V.

The aerial input of the tuner is asymmetrical. For use in symmetrical aerial systems, aerial transformers (baluns) are available (see ACCESSORIES).

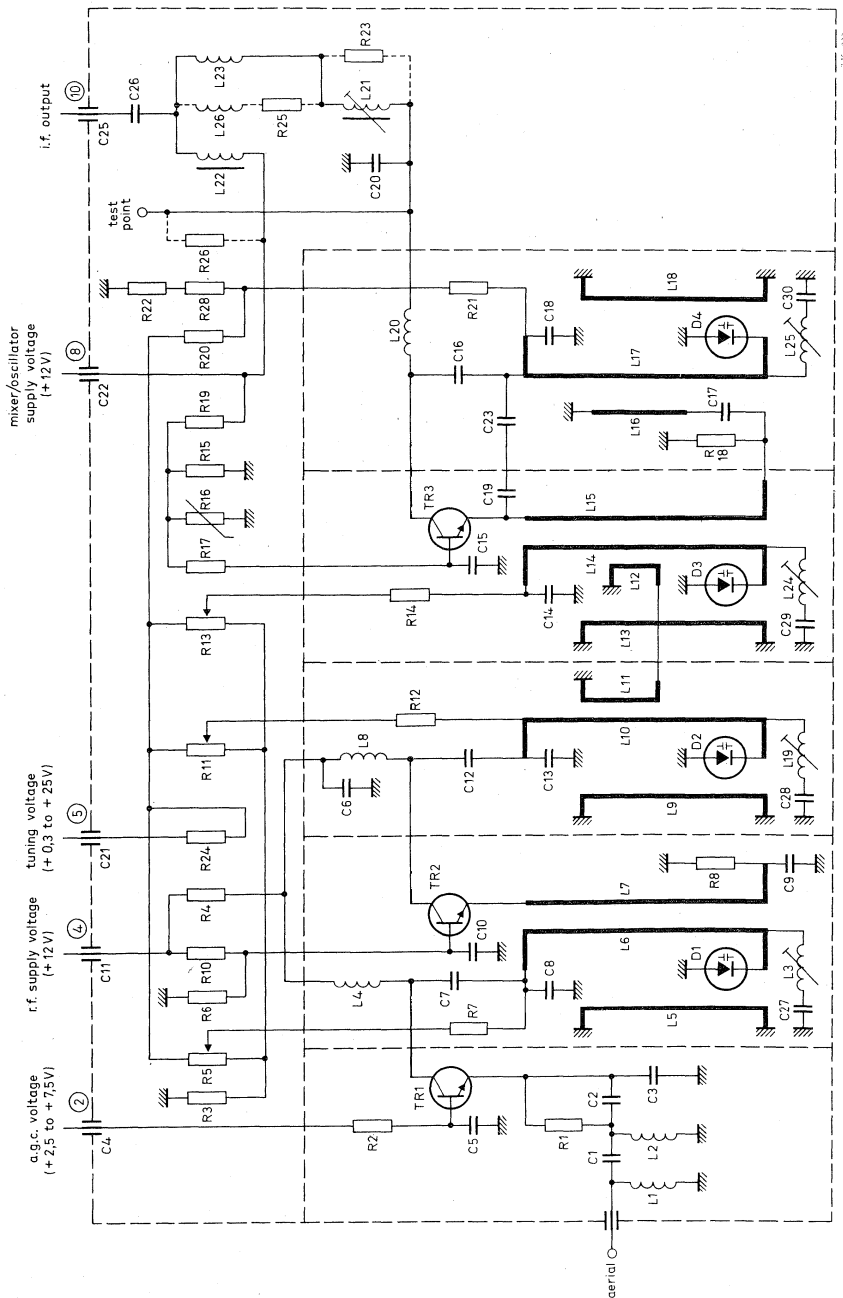
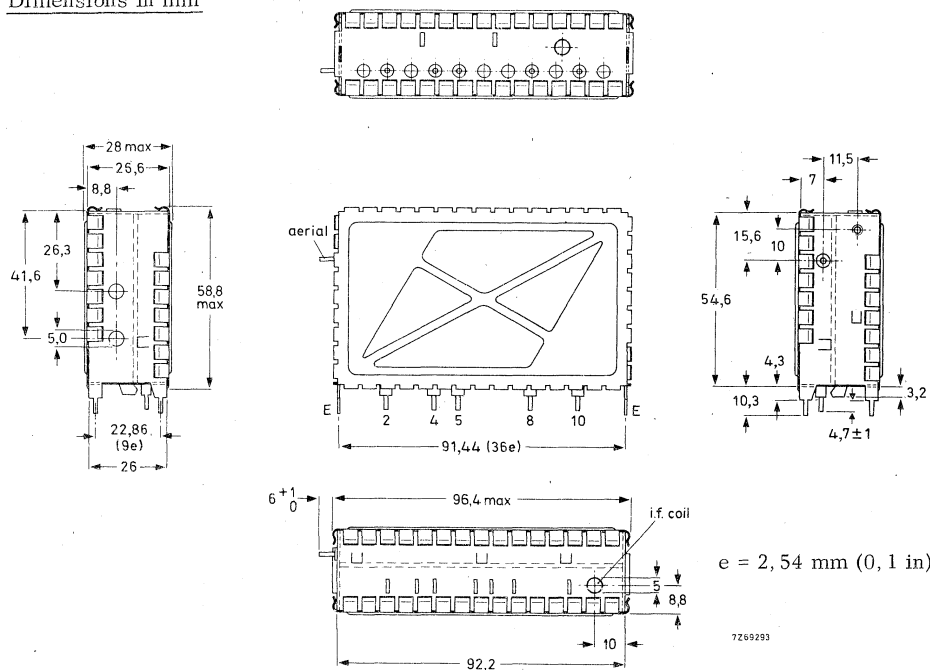

Fig. 1.

MECHANICAL DATA

Dimensions in mm



e = 2,54 mm (0,1 in)

7269293

Fig.2

- Terminal 2 = a.g.c. voltage, +2,5 to +7,5 V
- 4 = r.f. supply voltage, +12 V (approx. 8,8 to 13 mA)
- 5 = tuning voltage, +0,3 to +25 V
- 8 = mixer/oscillator supply voltage, +12 V (approx. 3,6 mA)
- 10 = i.f. output
- E = earth

Mounting

The tuner may be mounted by soldering it on to a printed-wiring board, using the piercing diagram shown in Fig. 3. (The tuner may also be mounted by means of a snap-in mount or a bracket. Information will be supplied upon request).

The tuner may be mounted anywhere in the receiver and there are no restrictions on orientation.

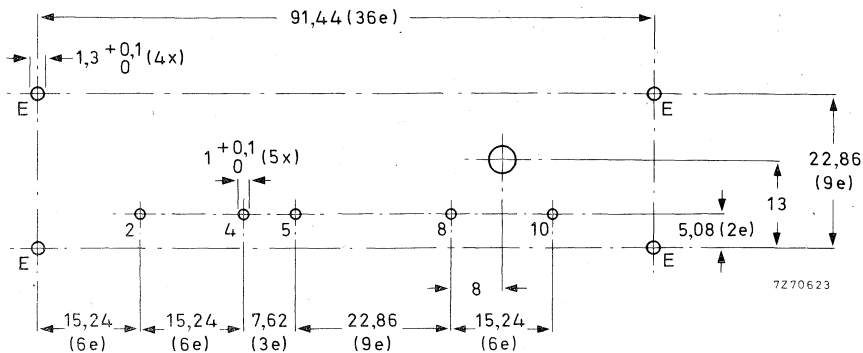

Fig. 3. Piercing diagram viewed from solder side of board; e = 2,54 mm (0,1 in)

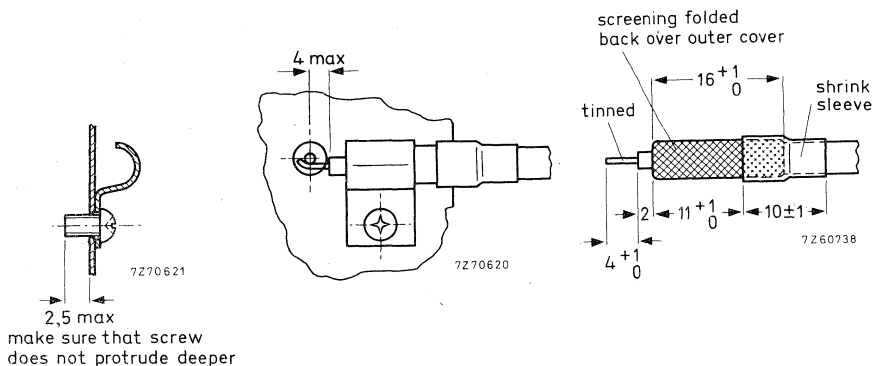

Fig. 4 Recommended fixing method of the aerial cable. Use a self-tapping screw.

ELECTRICAL DATA

Unless otherwise specified all electrical values apply at an ambient temperature of 25 ± 5 °C and a supply voltage of $12 \pm 0,3$ V

Semiconductors, r. f. amplifiers	2 x BF362				
mixer/oscillator	BF363				
tuning diodes	4 x BB205B				
Ambient temperature range					
operating	+5 to +55 °C				
storage	-25 to +85 °C				
Supply voltage	+12 V \pm 10%				
Current drawn from +12 V supply					
r. f. amplifiers	8,8 mA (at nominal gain) to 12 - 17 mA (at 30 dB gain reduction)				
mixer/oscillator	3,6 mA				
A.G.C. voltage (Fig. 5, typical curves)					
at nominal gain	+2,5 V				
at 30 dB gain reduction	approx. 6,0 V (max. 7,5 V)				
A.G.C. current at 30 dB gain reduction	max. 1,2 mA				
Tuning voltage range	+0,3 to +25 V				
Slope of tuning characteristic	min. 5 MHz/V				
Current drawn from 25 V tuning voltage supply	max. 20 μ A				
Frequency range	channel 21 (picture carrier 471,25 MHz) to channel 69 (picture carrier 855,25 MHz). Margin at the extreme channels min. 3 MHz				
Intermediate frequencies	<u>system G</u> <u>system I</u>				
picture	38,9 MHz 39,5 MHz				
sound	33,4 MHz 33,5 MHz				
Input impedance					
asymmetrical	75 Ω				
symmetrical	300 Ω (see ACCESSORIES)				
V.S.W.R. (between picture carrier and sound carrier)	<table border="1" style="display: inline-table; border-collapse: collapse;"> <tbody> <tr> <td style="padding: 2px;">v. s. w. r. at nom. gain, without a. g. c.</td> <td style="padding: 2px;">max. v. s. w. r. during gain con- trol up to 30 dB</td> </tr> <tr> <td style="text-align: center; padding: 2px;">max. 4,0</td> <td style="text-align: center; padding: 2px;">max. 6,0</td> </tr> </tbody> </table>	v. s. w. r. at nom. gain, without a. g. c.	max. v. s. w. r. during gain con- trol up to 30 dB	max. 4,0	max. 6,0
v. s. w. r. at nom. gain, without a. g. c.	max. v. s. w. r. during gain con- trol up to 30 dB				
max. 4,0	max. 6,0				

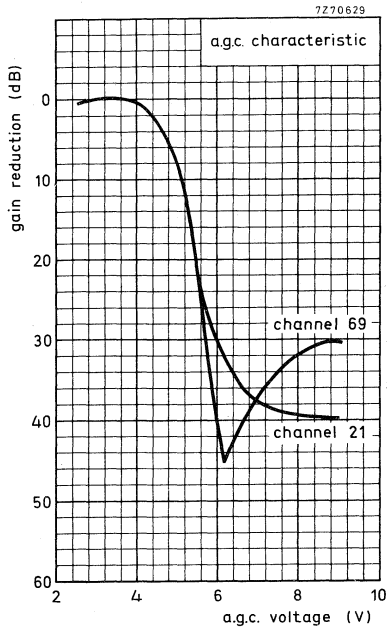

Fig. 5

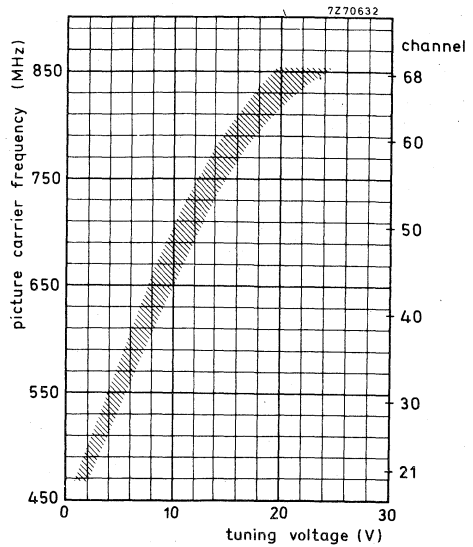

Fig. 6

A.G.C. range

min. 30 dB

R.F. curves

bandwidth
tilt

typ. 10 to 20 MHz

max. 4,0 dB (0 to 2 dB typical)

Power gain (see also ADDITIONAL INFORMATION)

channel 21
channel 50
channel 68

min. 17 dB

typ. 22 dB

typ. 22 dB

typ. 22 dB

Noise figure

channel 21
channel 50
channel 68

max. 10 dB

typ. 6,0 dB

typ. 6,5 dB

typ. 7,0 dB

I.F. rejection

min. 60 dB

Image rejection, channels 21 to 61

min. 53 dB

n + 4 rejection

min. 53 dB

(Obtained between the picture carrier of the wanted channel n and the sound carrier of an unwanted signal spaced 4 channels above the wanted channel.)

Signal handling

Minimum input signal (e. m. f.) producing cross modulation (1%) at nominal gain, in channel
(wanted signal: picture carrier frequency, interfering signal: sound carrier frequency).

typ. 8 mV (Note 1)

in band
(wanted signal: picture carrier frequency of channel X, interfering signal: picture carrier of channel X-5)

typ. 25 mV (Note 1)

Minimum input signal (e. m. f.) producing overloading, at nominal gain
at maximum a. g. c.

typ. 15 to 20 mV (Note 2)
min. 250 mV (Note 2)

Minimum input signal (e. m. f.) at nominal gain producing a shift of the oscillator frequency of 20 kHz

typ. 5 to 15 mV (Note 3)

Detuning of the i. f. output circuit as a result of tuning

max. 150 kHz

Shift of oscillator frequency at a change of the supply voltage of 10%

max. 500 kHz

during warm-up time (measured between 3 s and 60 s after switching on)

max. 200 kHz

at a gain reduction of 30 dB

max. 100 kHz

Drift of oscillator frequency
at a change of the ambient temperature from 25 to 50 °C

max. 1000 kHz

Note 1- This e. m. f. is referred to an impedance of 75 Ω.

1% cross modulation means that 1% of the modulation depth of the interfering signal is transferred to the wanted signal.

Note 2- This e. m. f. is referred to an impedance of 75 Ω.

Criterion of overloading: 30% compression of the synchronization pulses of a standard television signal or a noticeable deterioration of the picture quality.

Note 3- This e. m. f. is referred to an impedance of 75 Ω.

Oscillator radiation (oscillator voltages at the aerial terminal)

The oscillator radiation will be within the limits of BS905:1969 provided the circuit connected to the i. f. output is carefully shielded.

For the oscillator fundamentals use is made of the relaxed limits, assuming that the design of the i. f. amplifier of the receiver is such that a detuning of the oscillator of $-2,0$ MHz or $+0,6$ MHz from the nominal frequency will result in unacceptable picture and/or sound degradation.

Immunity from radiated interference

If the tuner, including the aerial connection (see Fig. 4) is installed in a professional manner, the immunity from radiated interference will be within the limits specified in BS905:1969.

If a higher safety margin, or another cable connection is required, use can be made of an immunity shield (see ACCESSORIES).

Microphonics

If the tuner is installed in a professional manner, there will be no noticeable microphonics.



ADDITIONAL INFORMATION

Measuring method of power gain

The i. f. output of the tuner should be terminated with the circuit given below.

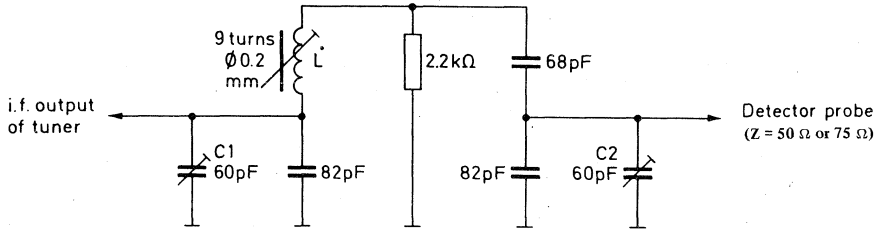

Fig. 7.

Feed an i. f. sweep signal to the emitter of the BF363 (mixer/oscillator) and make the oscillator inoperative (e.g. ferrite core in resonant chamber).

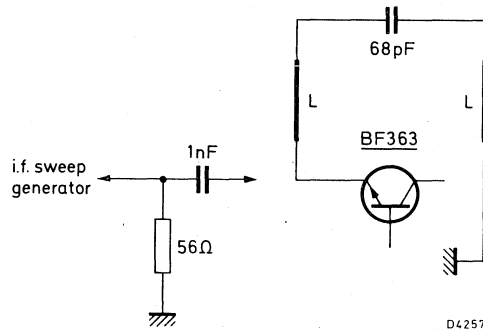

Fig. 8.

Adjust the trimmers C1 and C2, coil L (Fig. 7) and the i. f. output coil of the tuner (L21) to get the resonant curve with maximum gain as shown below.

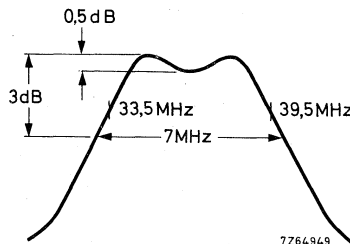

Fig. 9

Display the r.f. + i.f. curve of the tuner at 470 MHz and make, if necessary, small corrections in the alignment of C1, C2, L and L21 to get the markers 33,5 MHz and 39,5 MHz symmetrically on the slopes of the curve, and the peaks at equal amplitude.

Because the output impedance of the dummy circuit is 50 to 75 Ω , the power gain can be measured in the conventional manner by inserting tuner and dummy circuit between a 75 Ω source and a 75 Ω detector (or between a 50 Ω source and matching pad 50/75 Ω and a 50 Ω detector).

ACCESSORIES

Aerial input transformer ELC 1095, catalogue number 2422 542 10951, for converting the aerial input from 75 Ω asymmetric to 300 Ω symmetric.

Immunity shield for screening the aerial connection, consisting of:
shield, catalogue number 4313 132 01910
clamp, catalogue number 4313 132 01890

OTHER AVAILABLE VERSION

ELC1043/06 - See the relevant data sheet.



U.H.F. TELEVISION TUNER with diode tuning

These data should be read in conjunction with data on ELC1043/05.

This type is identical to ELC1043/05 except for the following:

- The i.f. output circuit consists of an i.f. coil with increased turns damped by a $680\ \Omega$ resistor. This changes the tuning range and Q of the i.f. output coil, making it suitable for coupling to a block filter input i.f. amplifier.
- The power gain is reduced to a nominal of 12 dB and a minimum of 9 dB by the damping resistor mentioned above.
- The same dummy circuit is used for measuring power gain but, as a result of damping the i.f. coil, a single tuned response will appear at the output, instead of the double tuned response, as in the case of ELC1043/05 (see below).

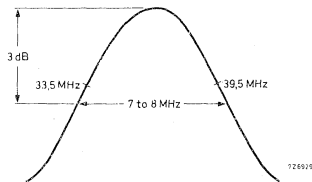

Fig. 1

V.H.F./U.H.F. TELEVISION TUNER with diode tuning

QUICK REFERENCE DATA

Systems	C. C. I. R. systems B and G
Channels	E2 to C (band I) E5 to E12 (band III) E21 to E69 (bands IV and V)
Intermediate frequencies	
picture	38,9 MHz
sound	33,4 MHz

APPLICATION

Designed to cover the v. h. f. and u. h. f. channels of C. C. I. R. systems B and G, including the italian channels.



DESCRIPTION

The ELC 2000 is a combined v. h. f. /u. h. f. tuner with electronic tuning and band switching, covering the v. h. f. band I including the Italian channel C (frequency range 47 to 88 MHz), the v. h. f. band III (frequency range 174 to 230 MHz), and the u. h. f. band (frequency range 470 to 860 MHz).

Mechanically, the tuner is built on a low-loss printed-wiring board, carrying all components, in a metal housing made of a rectangular frame and front and rear cover (see Fig. 2). The two aerial connections (v. h. f. and u. h. f.) are on the two frame sides, all other connections (supply voltages, a. g. c. voltage, tuning and switching voltages) are made via feedthrough capacitors in the under side. The mounting method is shown in Figs. 3 and 4.

Electrically, the tuner consists of a v. h. f. and u. h. f. part. The v. h. f. aerial signal is fed via an i. f. trap, combined with a high pass filter, to a tuned input circuit, which is connected to the emitter of the input transistor BF 200. The collector load of this transistor is formed by a double tuned circuit, transferring the signal to the base of the mixer transistor BF 182. The oscillator is equipped with a transistor BF 194. The four r. f. circuits are tuned by four capacitance diodes BB 106. Switching between v. h. f. I and III is achieved by four switching diodes BA 243/244.

The collector circuit of the mixer transistor is a single tuned i. f. resonant circuit, at the low end of which the i. f. signal is capacitively coupled out of the tuner.

An i. f. injection point is provided at the collector of the mixer, for aligning this circuit together with the i. f. amplifier of the television receiver.

The u. h. f. part of the tuner consists of a tuned input circuit, connected to the emitter of the amplifier transistor BF 180. The interstage network between this transistor and the self-oscillating mixer stage is formed by a double tuned circuit. A transistor BF 181 acts as a self-oscillating mixer. The four tuned u. h. f. circuits are tuned by four capacitance diodes BB 105 B.

The output of the self-oscillating mixer is fed to a double tuned i. f. circuit which is connected to the emitter of the v. h. f. mixer transistor BF 182, now operating as an i. f. amplifier in grounded base configuration. Band switching between v. h. f. and u. h. f. is achieved by another diode BA 243.

The tuner requires transistor supply voltages of +12 V, a switching voltage of +12 V, a. g. c. voltages, variable from +2,4 V (normal operating point) to about +7,5 V (maximum a. g. c.) and a tuning voltage, variable from +0,5 V to +28 V.

The aerial inputs of the tuner are asymmetrical. For use in symmetrical aerial systems, aerial transformers (baluns) are available (see ACCESSORIES).

ELC2000

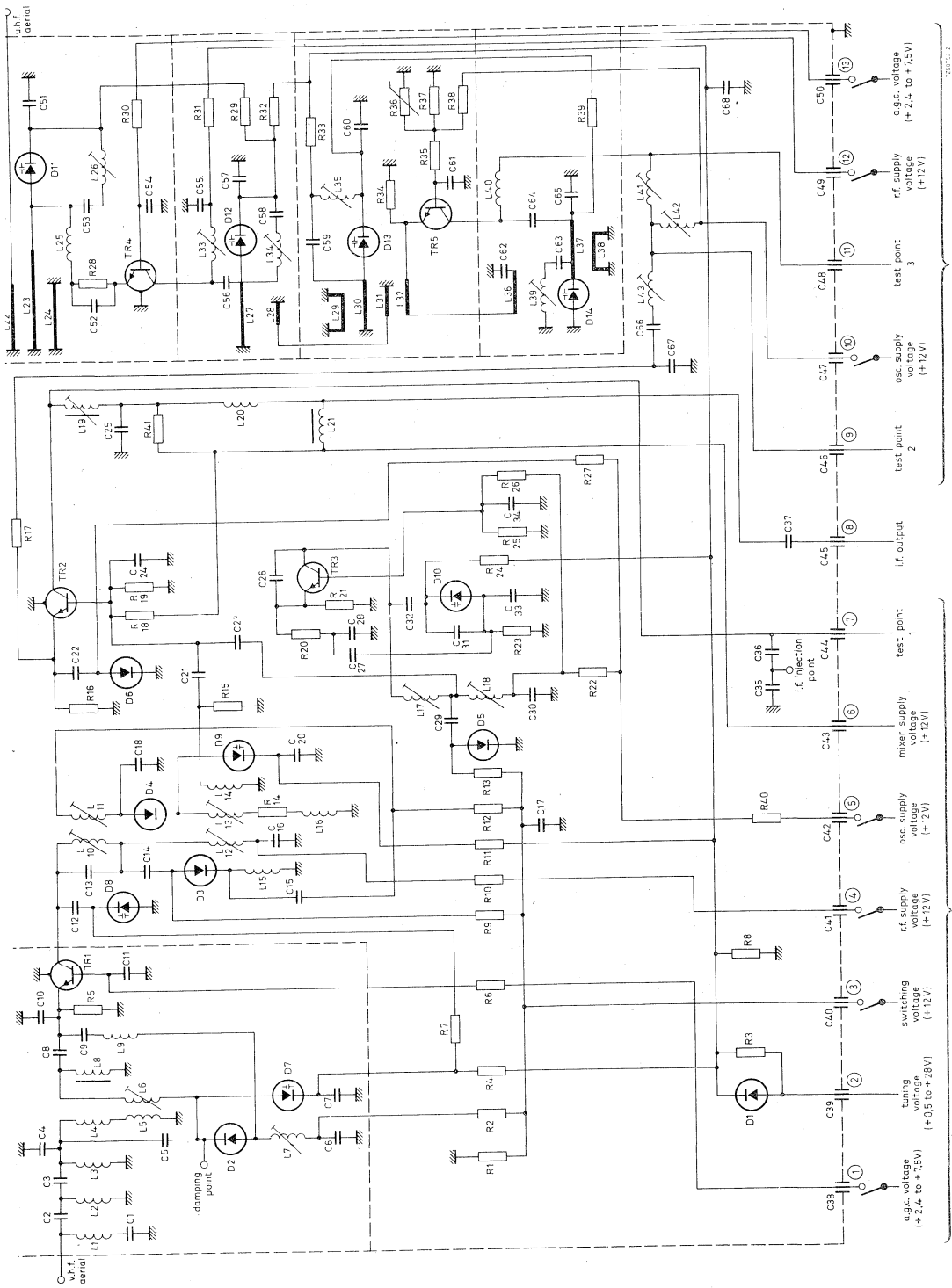

MECHANICAL DATA

Dimensions in mm

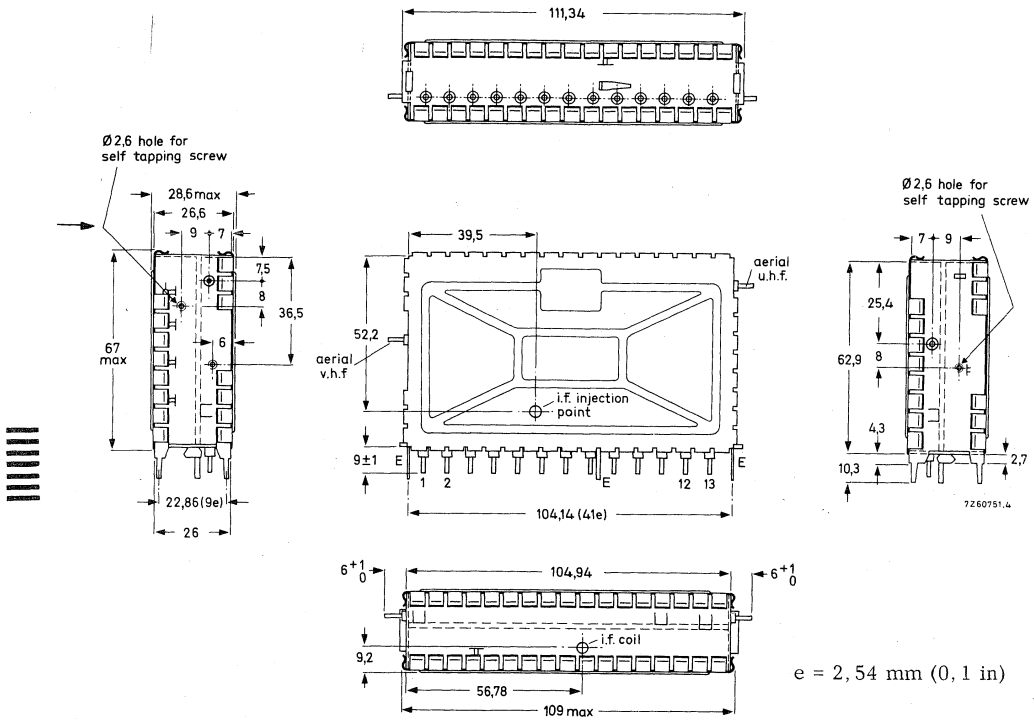

e = 2,54 mm (0,1 in)

Fig. 2

- Terminal 1 = a. g. c. voltage, v. h. f. , + 2,4 to + 7,5 V
- 2 = tuning voltage, + 0,5 to + 28 V
- 3 = switching voltage, + 12 V (approx. 20 mA)
- 4 = r. f. supply voltage, v. h. f. . + 12 V (approx. 3 to 10 mA)
- 5 = oscillator supply voltage, v. h. f. , + 12 V (approx. 6 mA)
- 6 = mixer supply voltage, v. h. f. . + 12 V (approx. 5 mA)
- 7 = test point 1, v. h. f.
- 8 = i. f. output
- 9 = test point 2 (alignment short)
- 10 = oscillator supply voltage, u. h. f. , + 12 V (approx. 4 mA)
- 11 = test point 3, u. h. f.
- 12 = r. f. supply voltage, u. h. f. , + 12 V (approx. 2,5 to 9,5 mA)
- 13 = a. g. c. voltage, u. h. f. , + 2,4 to + 7,5 V
- E = earth

Mounting

The tuner may be mounted by soldering it on to a printed-wiring board, using the piercing diagram shown in Fig. 3. (The tuner may also be mounted by means of a snap-in mount or a bracket. Information will be supplied upon request).
The tuner may be mounted anywhere in the receiver and there are no restrictions on orientation.

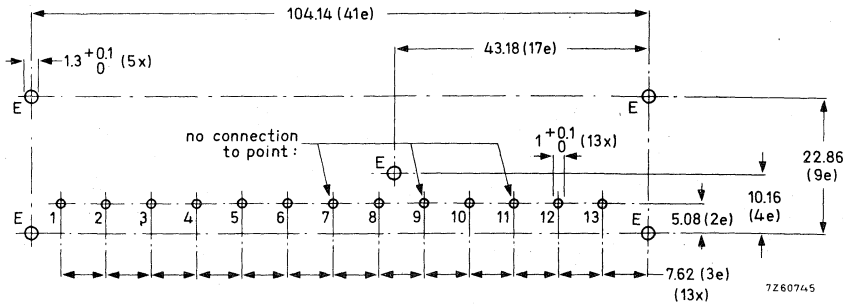

Fig. 3. Piercing diagram viewed from solder side of board; e = 2,54 mm (0, 1 in).
No connection must be made to the points 7, 9 and 11, as otherwise the oscillator radiation would increase.

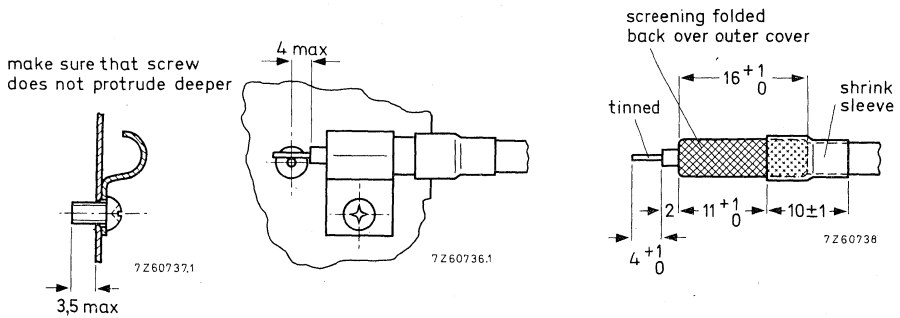

Fig. 4 Recommended fixing method of the aerial cables. Use a self-tapping screw.

ELECTRICAL DATA

Unless otherwise specified all electrical values apply at an ambient temperature of 25 ± 5 °C and a supply voltage of $12 \pm 0,3$ V.

Semiconductors

bands I and III, r. f. amplifier	BF200
mixer	BF182
oscillator	BF194
tuning diodes	4 x BB106
switching diodes	5 x BA243/244
bands IV and V, r. f. amplifier	BF180
mixer/oscillator	BF181
tuning diodes	4 x BB105B
drift compensating diode	BAW62

Ambient temperature range

operating	+5 to +55 °C
storage	-25 to +85 °C

Supply voltage

+12 V \pm 10%

Current drawn from +12 V supply

band I	14 to 21 mA	} depending on a. g. c. voltage
band III	34 to 41 mA	
bands IV and V	31,5 to 38 mA	

A. G. C. voltage (Figs 5, 6 and 7)

band I, at nominal gain	2,4 V
at 40 dB gain reduction	5,5 V (typical)
band III, at nominal gain	2,4 V
at 40 dB gain reduction	4,5 V (typical)
bands IV and V, at nominal gain	2,4 V
at 30 dB gain reduction	5,0 V (typical)

A. G. C. current

band I	} at 40 dB gain reduction	max. 0,8 mA
band III		max. 0,6 mA
bands IV and V, at 30 dB gain reduction		max. 0,7 mA

Tuning voltage range (Figs. 8, 9 and 10)

+0,5 to +28 V

Current drawn from 28 V tuning voltage supply

max. 36 μ A

Switching voltage

band I	open circuit
band III	+12 V
bands IV and V	+12 V

Note: In the band I position, the tuner produces a negative voltage (1 to 5 V) at terminal 3; this terminal must not be loaded with an external resistance below 10 M Ω .

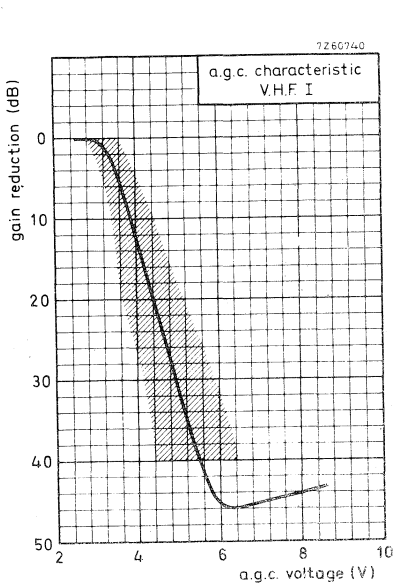

Fig. 5.

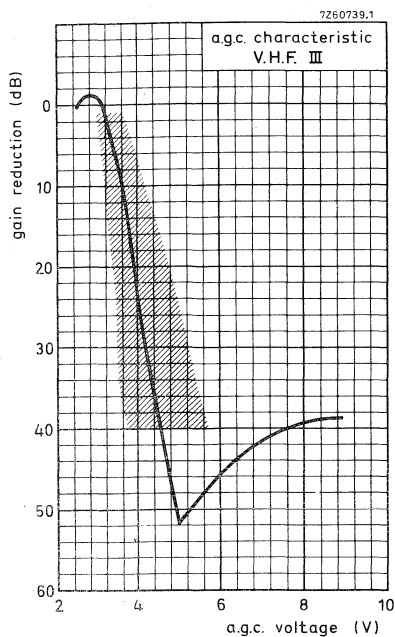

Fig. 6.

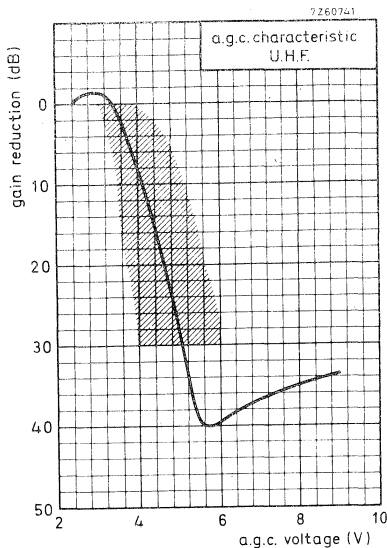

Fig. 7.

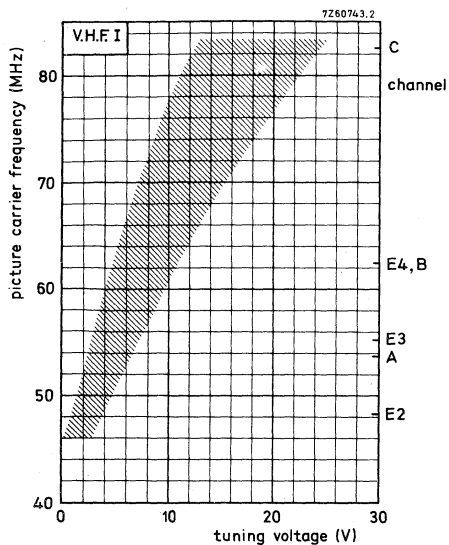

Fig. 8.

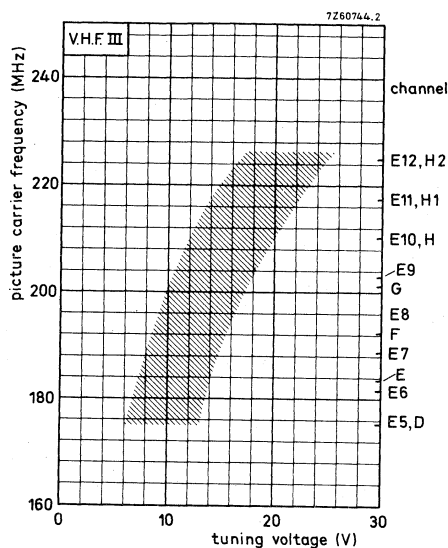

Fig. 9.

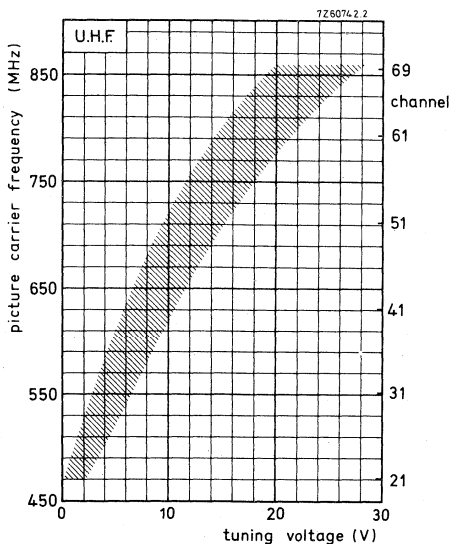

Fig. 10.

Frequency ranges				
band I		channel E2 (picture carrier 48,25 MHz)		
		to channel C (picture carrier 82,25 MHz).		
		Margin at the extreme channels: min.		
		1.2 MHz.		
band III		channel E5 (picture carrier 175,25 MHz)		
		to channel E12 (picture carrier 224,25 MHz).		
		Margin at the extreme channels: min.		
		2 MHz.		
bands IV and V		channel E21 (picture carrier 471,25 MHz)		
		to channel E69 (picture carrier 855,25 MHz).		
		Margin at the extreme channels: min.		
		3 MHz.		
Intermediate frequencies				
picture		38,9 MHz		
sound		33,4 MHz		
Input impedance				
asymmetrical		75 Ω		
symmetrical		300 Ω (see ACCESSORIES)		
V. S. W. R. (between picture carrier and sound carrier)		v. s. w. r. at nom. gain	max. v. s. w. r. during gain control	
		min. 1) max. 2)	min. 1) max. 2)	
band I (except channel C)		max. 3 max. 4	max. 4 max. 5	
band III (except channel E12)		max. 3 max. 4	max. 4 max. 5	
bands IV and V		max. 4	max. 5	
A. G. C. range				
band I		min. 40 dB		
band III		min. 40 dB		
bands IV and V		min. 30 dB		

1) Best value of V. S. W. R. between picture carrier and sound carrier.

2) Worst value of V. S. W. R. between picture carrier and sound carrier.

R.F. curves	
bandwidth, band I	typ. 10 to 15 MHz
band III	typ. 10 to 15 MHz
bands IV and V	typ. 15 to 25 MHz
tilt, band I	max. 3 dB
band III	max. 3 dB
bands IV and V, channels E21 to E60	max. 3 dB
channels E61 to E69	max. 4 dB
Power gain (see also MEASURING METHOD OF POWER GAIN)	
band I	min. 26 dB
channel E2	typ. 29 dB
channel C	typ. 32 dB
band III	min. 25 dB
channel E5	typ. 28 dB
channel E11	typ. 28 dB
bands IV and V	min. 25 dB
channel E21	typ. 32 dB
channel E31	typ. 29 dB
channel E69	typ. 33 dB
Noise figure	
band I	max. 8,5 dB
channel E4	typ. 6,5 dB
band III	max. 8 dB
channel E9	typ. 6,5 dB
bands IV and V	max. 12 dB
channel E21	typ. 8,0 dB
channel E51	typ. 9,5 dB
channel E69	typ. 10,5 dB
I.F. rejection	
band I, channel E2	min. 40 dB
channel C	min. 60 dB
band III	min. 60 dB
bands IV and V	min. 60 dB
Image rejection	
band I	min. 40 dB
band III	min. 60 dB
bands IV and V	min. 40 dB

Signal handling (see also Figs. 12 and 13)

Minimum input signal (e. m. f.) producing
cross modulation (1%) at nominal
gain, in channel

(wanted signal: picture carrier frequency,
interfering channel: sound carrier
frequency), v. h. f. I
v. h. f. III
u. h. f.

typ. 4 mV
typ. 4 mV
typ. 5 to 10 mV

} Note 1

in band

(wanted signal: picture carrier frequency
of channel X,

interfering signal: picture carrier of
channel X-2 (v. h. f.), X-5 (u. h. f.)

v. h. f. I
v. h. f. III
u. h. f.

typ. 15 to 60 mV
typ. 10 to 50 mV
typ. 15 to 50 mV

} Note 1

Minimum input signal (e. m. f.) producing
overloading, at nominal gain
at maximum a. g. c.

typ. 10 mV
typ. >200 mV

} Note 2

Minimum input signal (e. m. f.) at nominal
gain producing a shift of the oscillator
frequency of 10 kHz, band I

band III
bands IV and V

typ. >25 mV
typ. >25 mV
typ. 10 to 20 mV

} Note 3

Detuning of the i. f. output circuit as a result of
bandswitching and tuning with respect of channel E8

max. 400 kHz

Shift of oscillator frequency

at a change of the supply voltage of 10%

band I
band III
bands IV and V

max. 300 kHz
max. 300 kHz
max. 600 kHz

Note 1 - This e. m. f. is referred to an impedance of 75 Ω .

1% cross modulation means that 1% of the modulation depth of the interfering
signal is transferred to the wanted signal.

Note 2 - This e. m. f. is referred to an impedance of 75 Ω .

Criterion of overloading: 30% compression of the synchronization pulses of a
standard television signal or a noticeable deterioration of the picture quality.

Note 3 - This e. m. f. is referred to an impedance of 75 Ω .

during warm-up time (measured between 5 s and 15 min after switching on)

band I	max. 100 kHz
band III	max. 100 kHz
bands IV and V	max. 250 kHz
at a gain reduction of 30 dB	max. 100 kHz

Drift of oscillator frequency

at a change of the ambient temperature from 25 to 40 °C

band I	max. 300 kHz
band III	max. 300 kHz
bands IV and V	max. 500 kHz

Oscillator radiation

The tuner is in conformity with the radiation requirements of C. I. S. P. R. Recommendation No. 24/3, provided the following conditions are fulfilled:

- A low-pass filter (Fig. 11) with a cut-off frequency of about 300 MHz has to be inserted between the v. h. f. aerial terminal of the tuner and the aerial terminal of the receiver. Television receivers with a common v. h. f. /u. h. f. connector in combination with a low-pass/high-pass splitter do not need this additional filter.

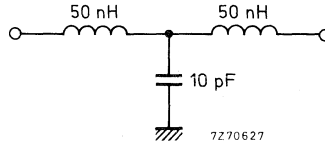

Fig. 11.

- No connections must be made to the terminals 7, 9, and 11.
- Earthing of the tuner and connections to the i. f. amplifier have to be made in such a way, that additional radiation is prevented.

Microphonics

If the tuner is installed in a professional manner, there will be no microphonics.

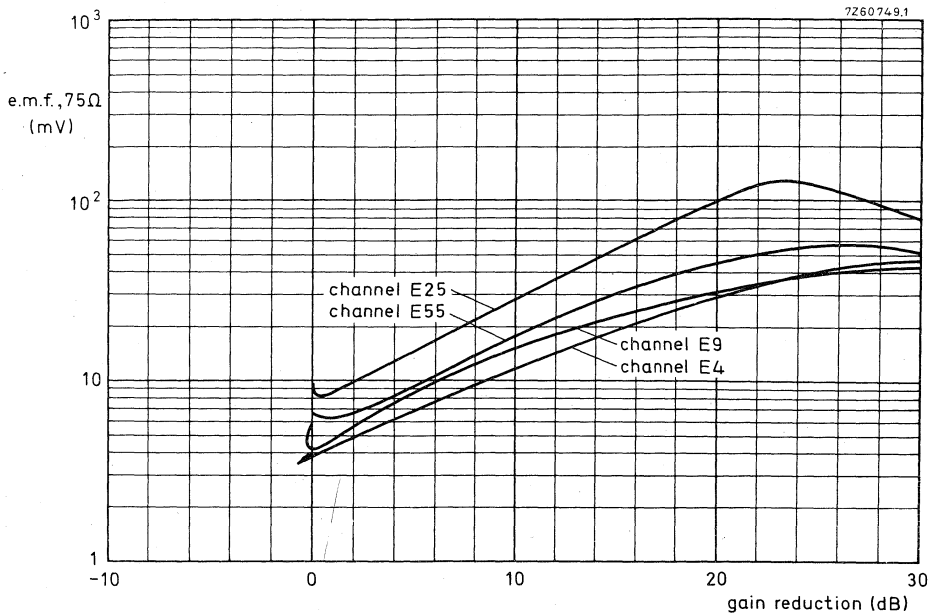

Fig. 12. Cross modulation, in channel.

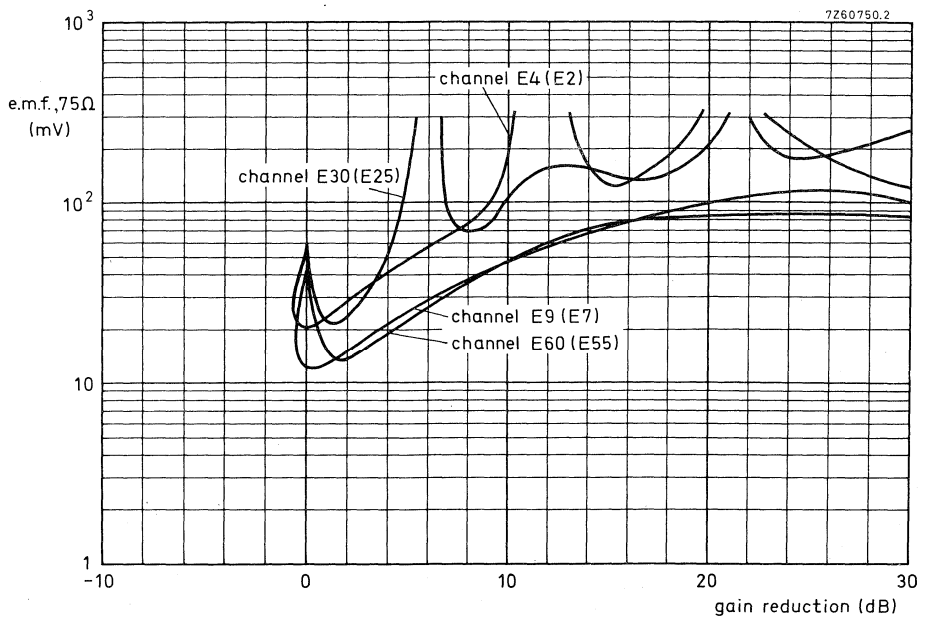

Fig. 13. Cross modulation, in band; the interfering channels are given between brackets.

APPLICATION INFORMATION

Connection of the tuner

For connection of the tuner the terminal location, Fig.2, should be consulted. If the tuner is used in receivers the chassis of which is connected to the mains, isolating capacitors according to the safety rules have to be inserted in the aerial leads. Five ways of connecting, depending on the number of switches available, are given below.

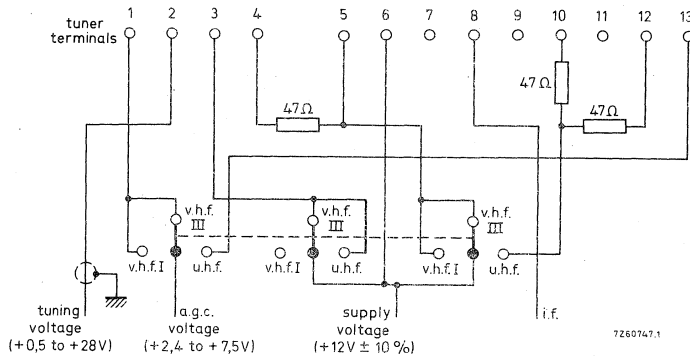

Fig. 14. Connection diagram with three switches.

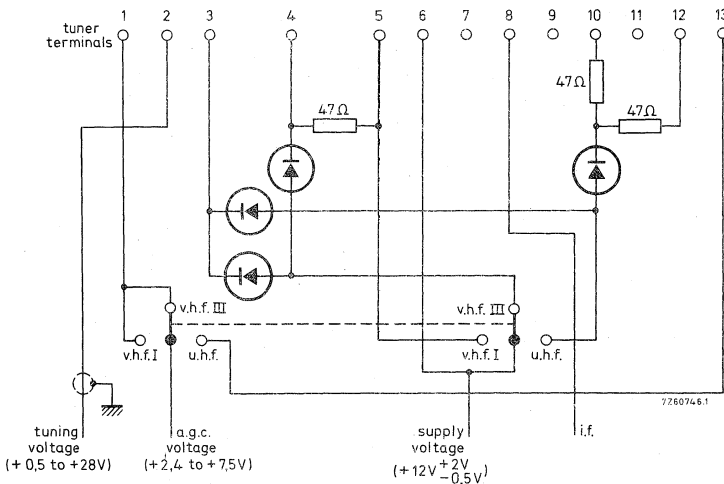

Fig. 15. Connection diagram with two switches.
All diodes: BAX13, BA217 or comparable silicon diodes.

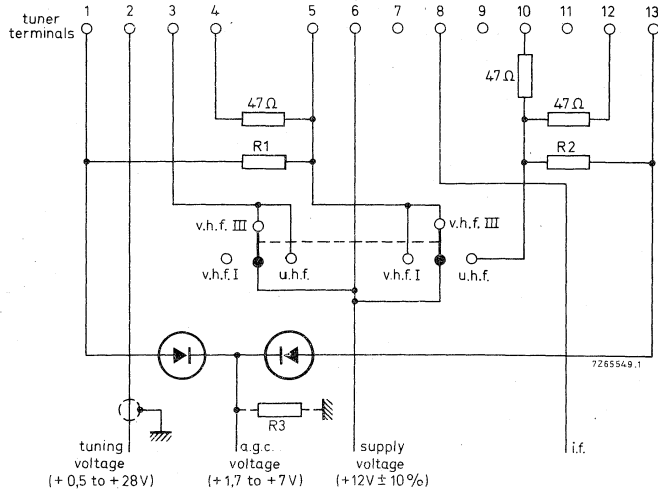

Fig. 16. Connection diagram with two switches.
All diodes: BAX 13, BA217 or comparable silicon diodes.
The values of R_1 , R_2 and R_3 are depending on a.g.c. circuit.

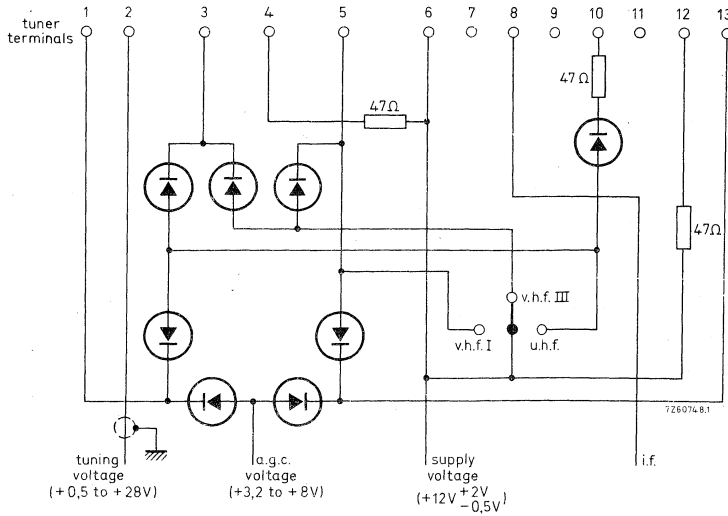

Fig. 17. Connection diagram with one switch.
All diodes: BAX 13, BA217 or comparable silicon diodes.

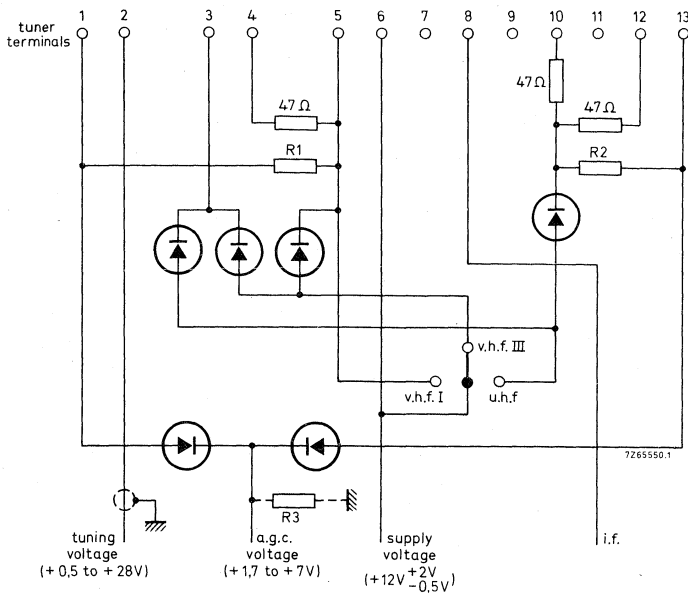

Fig. 18. Connection diagram with one switch.
All diodes: BAX13, BA217 or comparable
silicon diodes. The values of R_1 , R_2 and
 R_3 are depending on a.g.c. circuit.

Alignment of the i. f. circuit

The tuner is provided with an i. f. injection point at the collector of the mixer for aligning the i. f. circuit together with the i. f. amplifier of the television receiver (for the position of the i. f. injection point see Fig. 2).

The aligning should be done with the v. h. f. III band tuned. The tuning voltage should be 15 to 20 V.

If this injection method cannot be employed in the television receiver (e. g. because the injection point is not accessible or there is not enough i. f. signal available) use can be made of feeding the i. f. signal to test point 3 (terminal 11) via a capacitor of 0, 82 to 1 pF. The tuner must be switched to the u. h. f. position; the tuning voltage should be approx. 10 V. This injection method requires approx. 14 dB less signal than the first method. No permanent connection must be made to test point 3, otherwise the tuner may exceed the oscillator radiation limits.

MEASURING METHOD OF POWER GAIN

The i. f. output of the tuner should be terminated with the circuit given below.
The terminals 7, 9 and 11 should be not connected.

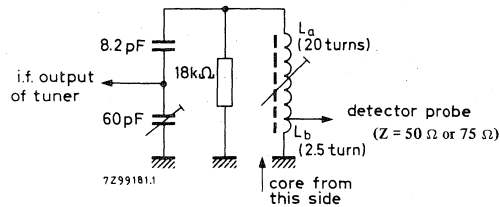

Fig. 19

Switch the tuner to the v. h. f. III band; the tuning voltage should be 15 to 20 V.
Feed an i. f. sweep signal (e. m. f. 500 to 1000 mV) to the i. f. injection point.
Adjust the trimmer (Fig. 19), tunable coil (L_a/L_b), i. f. output coil of the tuner L19 (Fig. 1) and the coupling between L_a and L_b to get the resonant curve as given below.

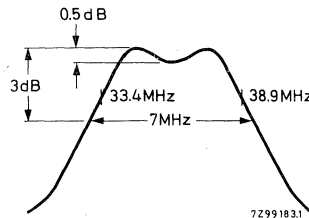

Fig. 20

Then display the r. f. + i. f. curve of the tuner at 190 MHz (picture carrier frequency) and make small corrections in the alignment of the i. f. coils (L_a/L_b and L19, if necessary, to get the markers 38,9 MHz and 33,4 MHz symmetrically on the slopes of the curve, and the peaks at equal amplitude.

Because the output impedance of the dummy circuit is 50 to 75 Ω , the power gain can be measured in the conventional manner by inserting tuner and dummy circuit between a 75 Ω source and a 75 Ω detector (or between a 50 Ω source and matching pad 50/75 Ω and a 50 Ω detector).

ACCESSORIES

Aerial input transformer ELC1094, v. h. f., catalogue number: 2422 542 10941

Aerial input transformer ELC2092, u. h. f., catalogue number: 2422 542 12921

V.H.F./U.H.F. TELEVISION TUNER

with diode tuning

QUICK REFERENCE DATA	
Systems	C. C. I. R. systems B and G
Channels ¹⁾	0 to 4 (low v. h. f. band) 5 to 11 (high v. h. f. band) 28 to 63 (u. h. f. band)
Intermediate frequencies	
picture	36,875 MHz
sound	31,375 MHz

APPLICATION

Designed to cover the Australian v. h. f. and u. h. f. channels of C. C. I. R. systems B and G.



¹⁾ In accordance with the publications of the Australian Broadcasting Control Board (ABCB).

DESCRIPTION

The ELC2060 is a combined v.h.f./u.h.f. tuner with electronic tuning and band switching, covering the low v.h.f. band with the channels 0 to 4 (frequency range 45 to 101 MHz), the high v.h.f. band with the channels 5 to 11 (frequency range 101 to 222 MHz), and the u.h.f. band with the channels 28 to 63 (frequency range 526 to 814 MHz).

Mechanically, the tuner is built on a low-loss printed-wiring board, carrying all components, in a metal housing made of a rectangular frame and front and rear cover (see Fig. 2). The two aerial connections (v.h.f. and u.h.f.) are on the two frame sides, all other connections (supply voltages, a.g.c. voltage, tuning and switching voltages) are made via feed-through capacitors in the under side. The mounting method is shown in Figs. 3 and 4.

Electrically, the tuner consists of v.h.f. and u.h.f. parts. The v.h.f. aerial signal is fed via an i.f. trap, combined with a high-pass filter, to a tuned input circuit, which is connected to the emitter of the input transistor BF200. The collector load of this transistor is formed by a double tuned circuit, transferring the signal to the base of the mixer transistor BF183. The oscillator is equipped with a transistor BF494. The four r.f. circuits are tuned by four capacitance diodes BB109G. A capacitance diode BB106 provides a frequency-dependent coupling of the r.f. input signal to the tuned input circuit. Switching between the low and high v.h.f. bands is done by four switching diodes (BA182, BA243, and BA244).

The collector circuit of the mixer transistor is a single tuned i.f. resonant circuit, at the low end of which the i.f. signal is capacitively coupled out of the tuner (low capacitance coupling). An i.f. injection point is provided at the collector of the mixer, for aligning this circuit together with the i.f. amplifier of the television receiver.

The u.h.f. part of the tuner consists of a tuned input circuit, connected to the emitter of the amplifier transistor BF183. The inter-stage network between this transistor and the self-oscillating mixer stage is formed by a double tuned circuit. A transistor BF181 acts as a self-oscillating mixer. The four tuned u.h.f. circuits are tuned by four capacitance diodes BB105B.

The output of the self-oscillating mixer is fed to a double tuned i.f. circuit which is connected to the emitter of the v.h.f. mixer transistor BF183, now operating as an i.f. amplifier in grounded-base configuration. Band switching between v.h.f. and u.h.f. is achieved by a diode BA243.

The tuner requires transistor supply voltages of +12 V, a switching voltage of +12 V, a.g.c. voltages, variable from +2,4 V (normal operating point) to about +7,5 V (maximum a.g.c.) and a tuning voltage, variable from +0,5 V to +28 V.

The aerial inputs of the tuner are asymmetrical. For use in symmetrical aerial systems, aerial transformers (baluns) are available (see ACCESSORIES).

MECHANICAL DATA

Dimensions in mm

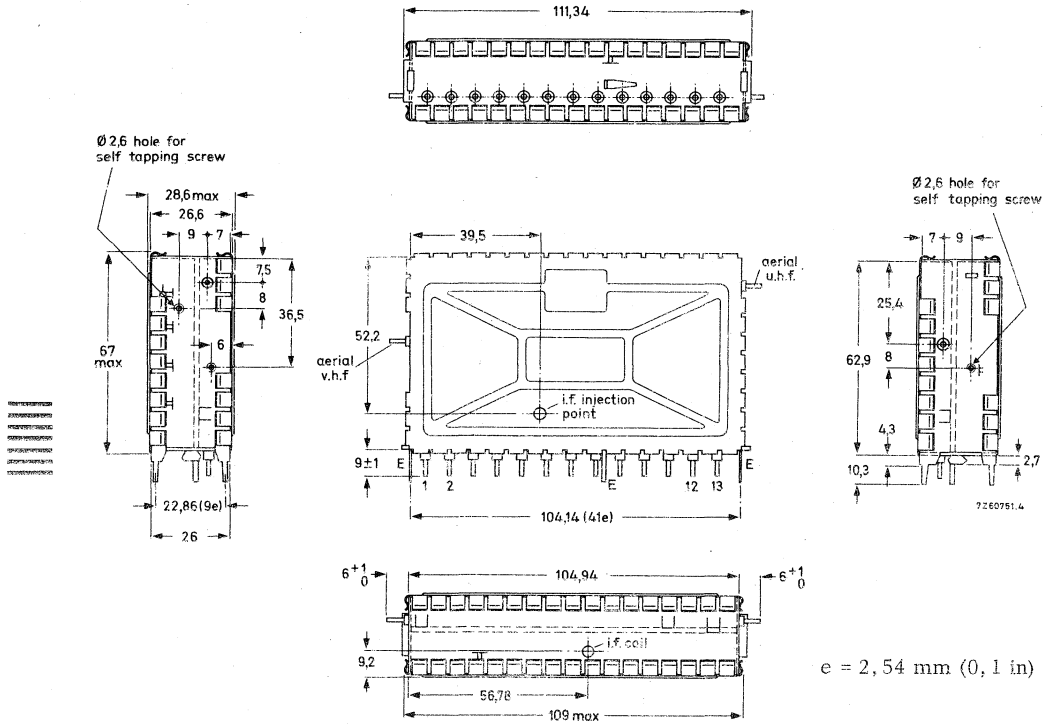

e = 2,54 mm (0,1 in)

Fig. 2.

- Terminal 1 = a.g.c. voltage, v.h.f., +2,4 to +7,5 V
- 2 = tuning voltage, +0,5 to +28 V
- 3 = switching voltage, +12 V (approx. 22 mA)
- 4 = r.f. supply voltage, v.h.f., +12 V (approx. 3 to 10 mA)
- 5 = oscillator supply voltage, v.h.f., +12 V (approx. 6 mA)
- 6 = mixer supply voltage, v.h.f., +12 V (approx. 5 mA)
- 7 = test point 1, v.h.f.
- 8 = i. f. output
- 9 = test point 2 (alignment short)
- 10 = oscillator supply voltage, u.h.f., +12 V (approx. 4,8 mA)
- 11 = test point 3; u.h.f.
- 12 = r.f. supply voltage, u.h.f., +12 V (approx. 2,5 to 9,5 mA)
- 13 = a.g.c. voltage, u.h.f., +2,4 to +7,5 V
- E = earth

Mounting

The tuner may be mounted by soldering it on to a printed-wiring board, using the piercing diagram shown in Fig. 3. (The tuner may also be mounted by means of a snap-in mount or a bracket. Information will be supplied upon request.)

The tuner may be mounted anywhere in the receiver and there are no restrictions on orientation.

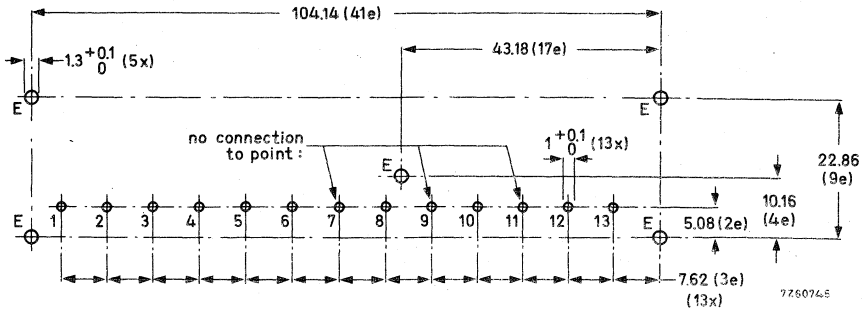

Fig. 3. Piercing diagram viewed from solder side of board; $e = 2,54 \text{ mm} (0,1 \text{ in})$.

No connection must be made to the points 7, 9 and 11, otherwise the oscillator radiation may increase.

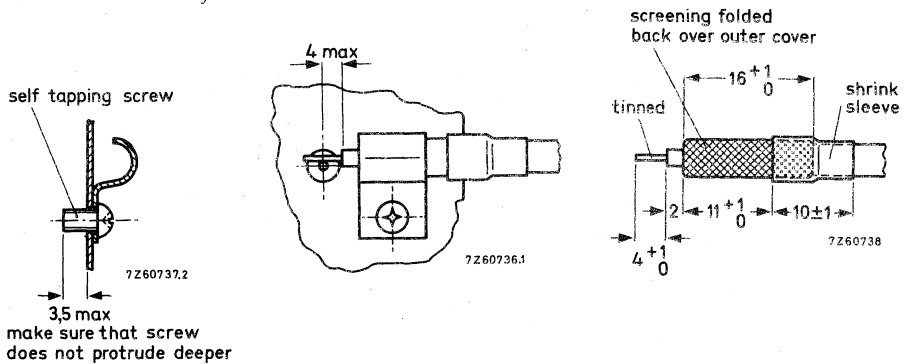

Fig. 4. Recommended fixing method of the aerial cables. Use a self-tapping screw.

ELECTRICAL DATA

Unless otherwise specified all electrical values apply at an ambient temperature of 25 ± 5 °C and a supply voltage of $12 \pm 0,3$ V.

Semiconductors

v.h.f. bands, r.f. amplifier	BF200
mixer	BF183
oscillator	BF494
tuning diodes	4 x BB109G
coupling diode	BB106
switching diodes	2 x BA182; 1 x BA243; 2 x BA244
u.h.f. band, r.f. amplifier	BF180
mixer/oscillator	BF181
tuning diodes	4 x BB105B
drift compensating diode	BAW62

Ambient temperature range

operating	+5 to +55 °C
storage	-25 to +85 °C

Relative humidity

max. 90%

Supply voltage

+12 V +10%, -15%

Current drawn from +12 V supply

low v.h.f. band	14 to 21 mA	} depending on a.g.c. voltage
high v.h.f. band	36 to 43 mA	
u.h.f. band	33,5 to 40 mA	

A.G.C. voltage (Figs. 5, 6 and 7)

low v.h.f. band, at nominal gain	2,4 V
at 40 dB gain reduction	typ. 5,5 V
high v.h.f. band, at nominal gain	2,4 V
at 40 dB gain reduction	typ. 4,5 V
u.h.f. band, at nominal gain	2,4 V
at 30 dB gain reduction	typ. 5,0 V

A.G.C. current

low v.h.f. band	} at 40 dB gain reduction	max. 0,8 mA
high v.h.f. band		max. 0,6 mA
u.h.f. band, at 30 dB gain reduction		max. 0,7 mA

Tuning voltage range (Figs. 8, 9 and 10)

+0,5 to +28 V

Current drawn from 28 V tuning voltage supply

max. 36 µA

Note: The source impedance of the tuning voltage offered to terminal 2, must be max. 30 kΩ at tuning voltages below 2 V.

Switching voltage

low v.h.f. band	open circuit
high v.h.f. band	+12 V
u.h.f. band	+12 V

Note: In the low v.h.f. band position, the tuner produces a negative voltage (1 to 5 V) at terminal 3; this terminal must not be loaded with an external resistance below 20 MΩ.

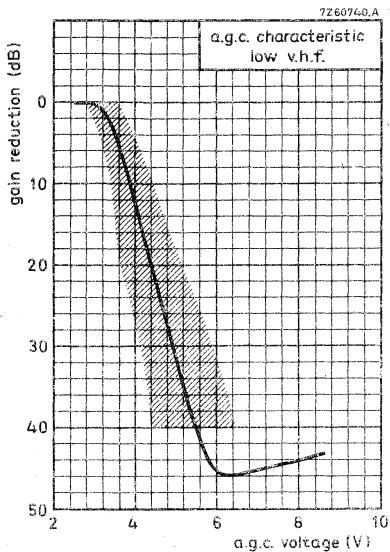

Fig. 5

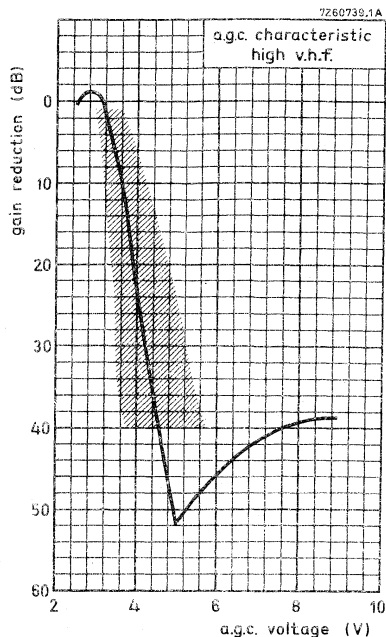

Fig. 6.

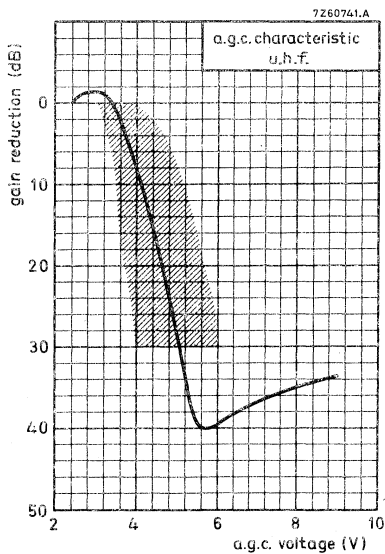

Fig. 7.



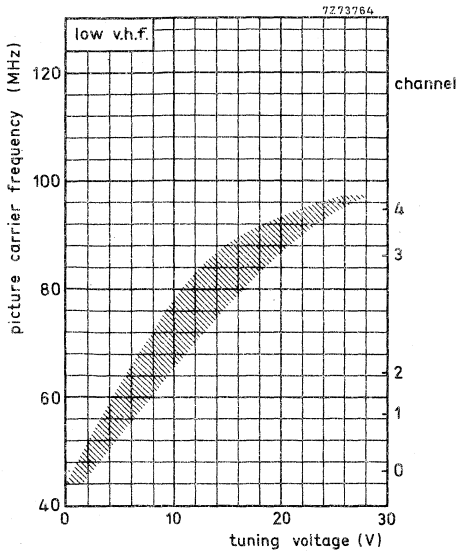

Fig. 8.

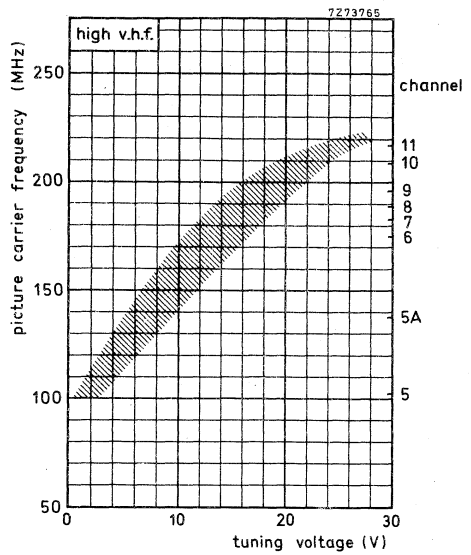

Fig. 9.

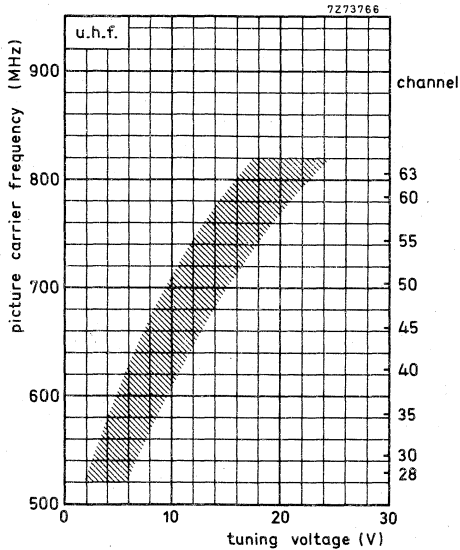

Fig. 10.

Frequency ranges					
low v. h. f. band				channel 0 (picture carrier 46,25 MHz)	to channel 4 (picture carrier 95,25 MHz).
				Margin at the extreme channels: min.	1,5 MHz.
high v. h. f. band				channel 5 (picture carrier 102,25 MHz)	to channel 11 (picture carrier 216,25 MHz).
				Margin at the extreme channels: min.	2 MHz.
u. h. f. band				channel 28 (picture carrier 527,25 MHz)	to channel 63 (picture carrier 807,25 MHz).
				Margin at the extreme channels: min.	3 MHz.
Intermediate frequencies					
picture				36,875 MHz	
sound				31,375 MHz	
				The oscillator frequency is higher than the input-signal frequency.	
Input impedance					
asymmetrical				75 Ω	
symmetrical				300 Ω (see ACCESSORIES)	
V.S.W.R. (between picture carrier and sound carrier)				v. s. w. r. at nom. gain	max. v. s. w. r. during gain control
				min. 1) max. 2)	min. 1 max. 2)
low v. h. f. band				max. 3 max. 5	max. 4 max. 5,5
high v. h. f. band, channels 5A to 11				max. 4 max. 5	max. 4,5 max. 5,5
channel 5				max. 4 max. 6	max. 4,5 max. 6
u. h. f. band				max. 4	max. 5
A.G.C. range					
low v. h. f. band				min. 40 dB	
high v. h. f. band				min. 40 dB	
u. h. f. band				min. 30 dB	

¹⁾ Best value of V.S.W.R. between picture carrier and sound carrier.

²⁾ Worst value of V.S.W.R., between picture carrier and sound carrier.

R. F. curves at nominal gain		
bandwidth, low v. h. f. band		typ. 9 to 13 MHz
high v. h. f. band		typ. 9 to 14 MHz
u. h. f. band		typ. 13 to 18 MHz
tilt, low v. h. f. band		max. 3 dB
high v. h. f. band, channels 5 and 5A		max. 3,5 dB
channels 6 to 11		max. 3 dB
u. h. f. band		max. 3 dB
Power gain (see also MEASURING METHODS)		
v. h. f. bands, except channel 5		min. 25 dB
channel 5		min. 21 dB
channel 0		typ. 31 dB
channel 4		typ. 29 dB
channel 5		typ. 24 dB
channel 8		typ. 29 dB
u. h. f. band		min. 25 dB
channel 28		typ. 30 dB
channel 63		typ. 32 dB
Noise figure		
low v. h. f. band		max. 9 dB
channel 0		typ. 7 dB
channel 4		typ. 7 dB
high v. h. f. band		
channel 5		max. 11 dB
		typ. 9 dB
channel 5A		max. 8,5 dB
		typ. 6,5 dB
channels 6 to 11		max. 8 dB
		typ. 5 dB
u. h. f. band		max. 12 dB
channel 28		typ. 8,5 dB
channel 63		typ. 9,5 dB
I. F. rejection		
v. h. f. bands, channel 0		min. 40 dB
channels 1 and 2		min. 50 dB
channels 3 to 11		min. 60 dB
u. h. f. band		min. 60 dB
Image rejection		
low v. h. f. band		min. 50 dB
high v. h. f. band		min. 60 dB
u. h. f. band		min. 40 dB

Signal handling (see also Figs. 12 and 13)

Minimum input signal (e. m. f.) producing cross-modulation (1%) at nominal gain, in channel			
(wanted signal: picture carrier frequency, interfering channel: sound carrier frequency), low v. h. f. band	typ.	4 mV	1)
high v. h. f. band	typ.	4 mV	
u. h. f. band	typ.	5 to 10 mV	
in band			
(wanted signal: picture carrier frequency of channel N, interfering signal: picture carrier of channel N-2 (v. h. f.), N-5 (u. h. f.))			
low v. h. f. band	typ.	15 to 60 mV	1)
high v. h. f. band	typ.	10 to 50 mV	
u. h. f. band	typ.	15 to 50 mV	
Minimum input signal (e. m. f.) producing overloading, at nominal gain at maximum a. g. c.	typ.	10 mV	2)
	typ.	>200 mV	
Minimum input signal (e. m. f.) at nominal gain producing a shift of the oscillator frequency of 10 kHz, low v. h. f. band	typ.	25 mV	3)
high v. h. f. band	typ.	25 mV	
u. h. f. band	typ.	10 to 20 mV	
Tuning range of the i. f. output circuit (see also MEASURING METHODS)			max. 31,5 to min. 37,5 MHz
Detuning of the i. f. output circuit as a result of band switching and tuning with respect of channel 8			max. 400 kHz
Shift of oscillator frequency at a change of the supply voltage of 10%			
v. h. f. bands, channels 0 to 4			max. 500 kHz
channels 5 to 11			max. 300 kHz
u. h. f. band			max. 600 kHz
at a gain reduction of 30 dB			max. 100 kHz

1) This e. m. f. (open voltage) is referred to an impedance of 75 Ω .

1% cross-modulation means that 1% of the modulation depth of the interfering signal is transferred to the wanted signal.

2) This e. m. f. (open voltage) is referred to an impedance of 75 Ω .

Criterion of overloading: 30% compression of the synchronization pulses of a standard television signal or a noticeable deterioration of the picture quality.

3) This e. m. f. (open voltage) is referred to an impedance of 75 Ω .

Drift of oscillator frequency

during warm-up time (measured between 5 s
and 15 min after switching on)

v. h. f. bands	max. 200 kHz
u. h. f. band	max. 250 kHz

at a change of the ambient temperature
from 25 to 50 °C

v. h. f. bands	max. 500 kHz
u. h. f. band	max. 1000 kHz

Oscillator radiation

The tuner is in conformity with the radiation requirements of the Australian Standard AS 1053-1973 and of C. I. S. P. R. Recommendation No. 24/3, provided the following conditions are fulfilled:

- A low-pass filter (Fig. 11) with a cut-off frequency of about 300 MHz has to be inserted between the v. h. f. aerial terminal of the tuner and the aerial terminal of the receiver. Television receivers with a common v. h. f. /u. h. f. connector in combination with a low-pass/high-pass splitter ¹⁾ may not need this additional filter.

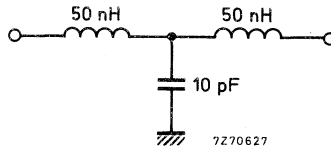

Fig. 11.

- No connections must be made to the terminals 7, 9 and 11.
- Earthing of the tuner and connections to the i. f. amplifier have to be made in such a way, that additional radiation is prevented.

Microphonics

If the tuner is installed in a professional manner, there will be no microphonics.

¹⁾ E. g. coaxial aerial input assembly 3122 127 10450.

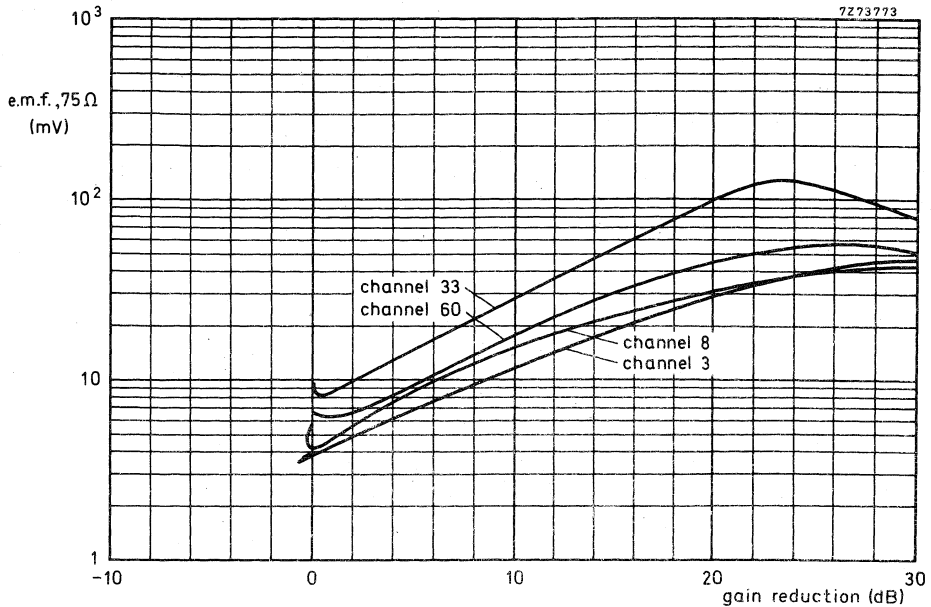

Fig. 12. Cross-modulation, in channel.

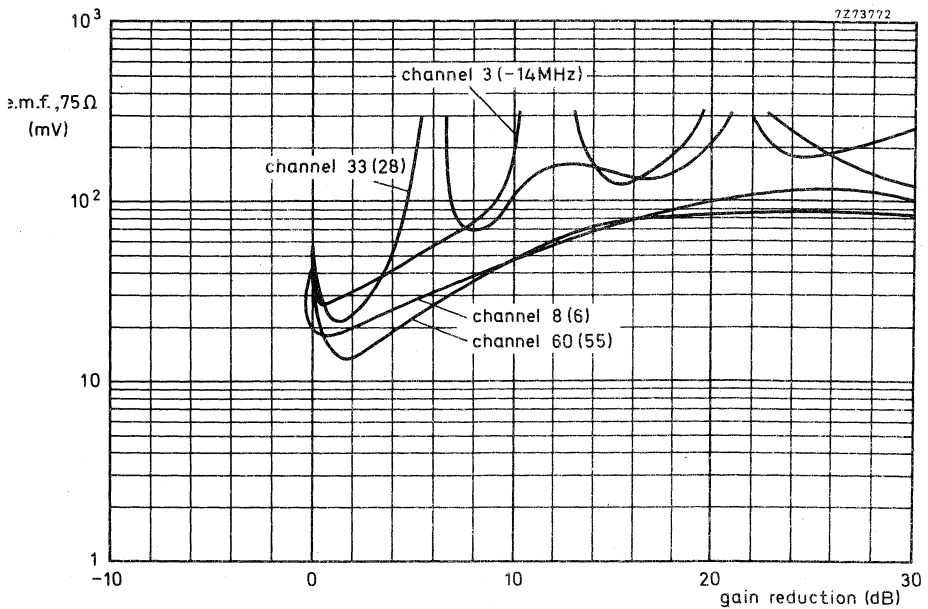

Fig. 13. Cross-modulation, in band; the interfering channels are given between brackets.

APPLICATION INFORMATION

Connection of the tuner

For connection of the tuner the terminal location, Fig.2, should be consulted. If the tuner is used in receivers the chassis of which is connected to the mains, isolating capacitors according to the safety rules have to be inserted in the aerial leads. Five ways of connecting, depending on the number of switches available, are given below.

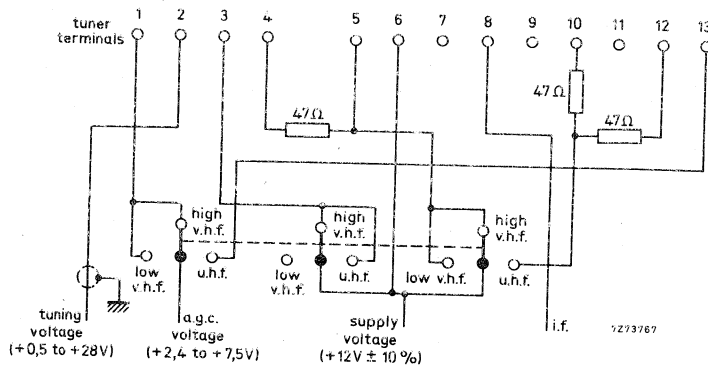

Fig. 14. Connection diagram with three switches.

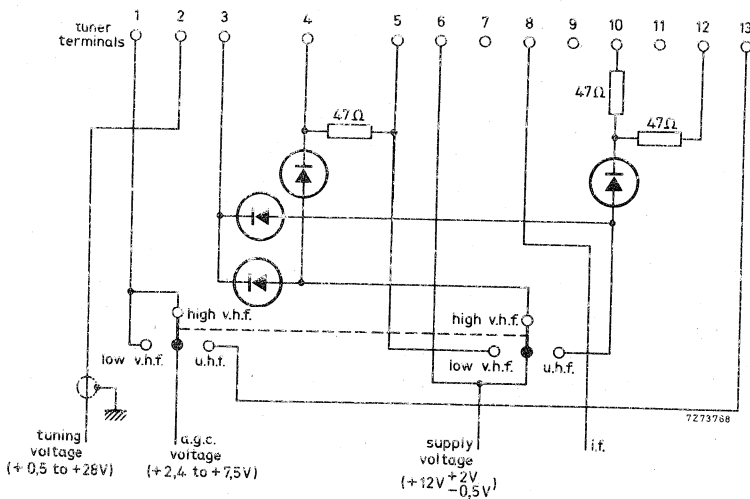

Fig. 15. Connection diagram with two switches.

All diodes: BAX13, BA217 or comparable silicon diodes.

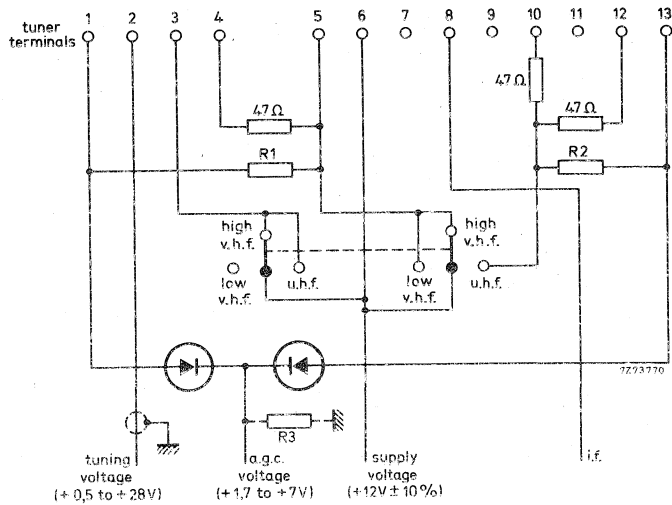

Fig. 16. Connection diagram with two switches.
All diodes: BAX13, BA217 or comparable silicon diodes.
The values of R₁, R₂ and R₃ depend on a.g.c. circuit.

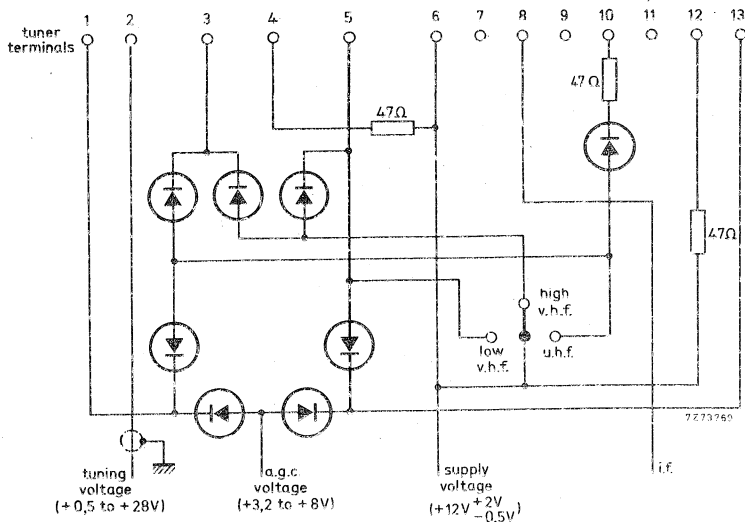

Fig. 17. Connection diagram with one switch.
All diodes: BAX13, BA217 or comparable silicon diodes.

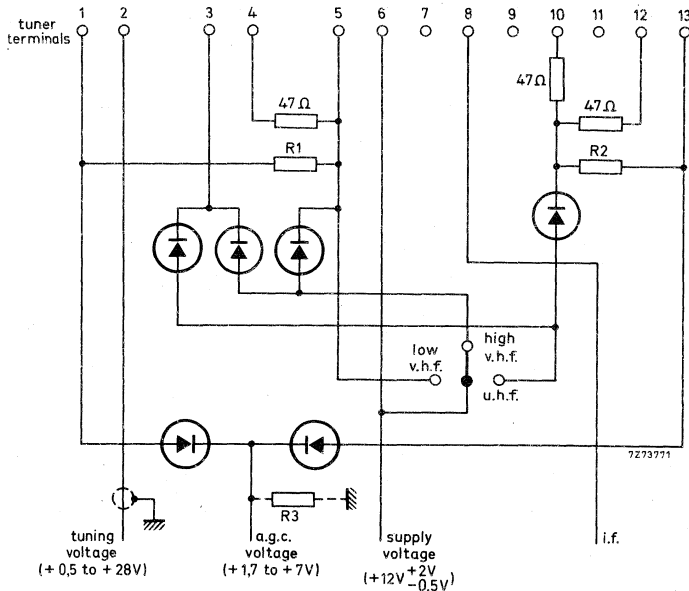

Fig. 18. Connection diagram with one switch.

All diodes: BAX13, BA217 or comparable silicon diodes.

The values of R_1 , R_2 and R_3 depend on a.g.c. circuit.

Alignment of the i. f. circuit

The tuner is provided with an i. f. injection point at the collector of the mixer for aligning the i. f. circuit together with the i. f. amplifier of the television receiver (for the position of the i. f. injection point see Fig. 2).

The alignment should be done with the high v. h. f. band tuned. The tuning voltage should be 15 to 20 V.

If this injection method cannot be employed in the television receiver (e.g. because the injection point is not accessible or there is not enough i. f. signal available), the i. f. signal can be fed to test point 3 (terminal 11) via a capacitor of 0,82 to 1 pF. The tuner must be switched to the u. h. f. position; the tuning voltage should be approx. 10 V. This injection method requires approx. 14 dB less signal than the first method. No permanent connection must be made to test point 3, otherwise the tuner may exceed the oscillator radiation limits.

MEASURING METHODSPower gain

The i. f. output of the tuner should be terminated with the dummy circuit given below. The terminals 7, 9 and 11 should be not connected.

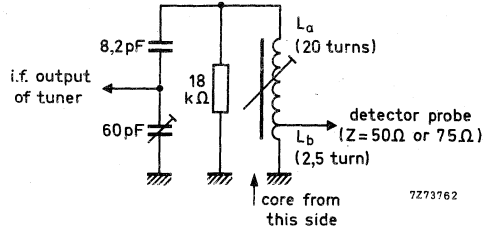

Fig. 19.

The dummy circuit should be aligned as follows.

Switch the tuner to the high v. h. f. band; the tuning voltage should be 15 to 20 V.

Feed an i. f. sweep signal (500 to 1000 mV) to the i. f. injection point.

Adjust the trimmer (Fig. 19), tunable coil (L_a/L_b), i. f. output coil of the tuner L519 (Fig. 1) and the coupling between L_a and L_b to get the resonant curve as given below.

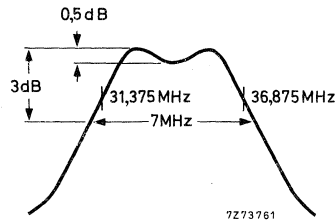

Fig. 20.

Then display the r. f. + i. f. curve of the tuner at 190 MHz (picture carrier frequency) and make small corrections in the alignment of the i. f. coils (L_a/L_b and L519), if necessary, to get the markers 36, 875 MHz and 31, 375 MHz symmetrically on the slopes of the curve, and the peaks at equal amplitude.

Because the output impedance of the dummy circuit is 50 to 75 Ω , the power gain can be measured in the conventional manner by inserting tuner and dummy circuit between a 75 Ω source and a 75 Ω detector (or between a 50 Ω source and matching pad 50/75 Ω and a 50 Ω detector).

Tuning range of i. f. output circuit

The i. f. output of the tuner should be terminated with the circuit given in Fig. 21. The terminals 7, 9 and 11 should not be connected.

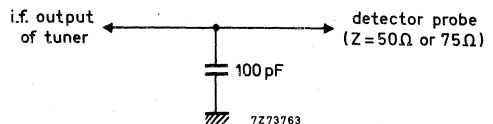

Fig. 21.

ELC2060

V.H.F./U.H.F. TELEVISION TUNER
with diode tuning

3122 128 56991

ACCESSORIES

Aerial input transformer ELC1094, v. h. f. , catalogue number : 2422 542 10941;
aerial input transformer ELC2092, u. h. f. , catalogue number : 2422 542 12921;
coaxial aerial input assembly, catalogue number : 3122 127 10450.

V.H.F./U.H.F. TELEVISION TUNER

with diode tuning

QUICK REFERENCE DATA	
System	C.C.I.R. system I
Channels (South African channel distribution)	4 to 13 (v.h.f. band) 21 to 69 (u.h.f. band)
Intermediate frequencies	
picture	38,9 MHz
sound	32,9 MHz

APPLICATION

Designed to cover the South African v.h.f. and u.h.f. channels of C.C.I.R. system I.

DESCRIPTION

The ELC2070 is a combined v.h.f. /u.h.f. tuner with electronic tuning and band switching, covering the South African v.h.f. band (frequency range 174 to 254 MHz) and the u.h.f. band (frequency range 470 to 860 MHz).

Mechanically, the tuner is built on a low-loss printed-wiring board, carrying all components, in a metal housing made of a rectangular frame and front and rear cover (see Fig.2). The two aerial connections (v.h.f. and u.h.f.) are on the two frame sides, all other connections (supply voltages, a.g.c. voltage and tuning voltage) are made via feed-through capacitors in the under side. The mounting method is shown in Figs. 3 and 4.

Electrically, the tuner consists of v.h.f. and u.h.f. parts. The v.h.f. aerial signal is fed via an i.f. trap, combined with a high-pass filter, to a tuned input circuit, which is connected to the emitter of the input transistor BF200. The collector load of this transistor is formed by a double tuned circuit, transferring the signal to the base of the mixer transistor BF182. The oscillator is equipped with a transistor BF494. The four r.f. circuits are tuned by four capacitance diodes BB106.

The collector circuit of the mixer transistor is a single tuned i.f. resonant circuit, at the low end of which the i.f. signal is capacitively coupled out of the tuner.

An i.f. injection point is provided at the collector of the mixer, for aligning this circuit together with the i.f. amplifier of the television receiver.

The u.h.f. part of the tuner consists of a tuned input circuit, connected to the emitter of the amplifier transistor BF180. The inter-stage network between this transistor and the self-oscillating mixer stage is formed by a double tuned circuit. A transistor BF181 acts as a self-oscillating mixer. The four tuned u.h.f. circuits are tuned by four capacitance diodes BB105B.

The output of the self-oscillating mixer is fed to a double tuned i.f. circuit which is connected to the emitter of the v.h.f. mixer transistor BF182, now operating as an i.f. amplifier in grounded-base configuration. Band switching between v.h.f. and u.h.f. is achieved by a diode BA243.

The tuner requires transistor supply voltages of +12 V, a.g.c. voltages, variable from +2,4 V (normal operating point) to about +7,5 V (maximum a.g.c.), and a tuning voltage, variable from +0,5 V to +28 V.

The aerial inputs of the tuner are asymmetrical. For use in symmetrical aerial systems, aerial transformers (baluns) are available (see ACCESSORIES).

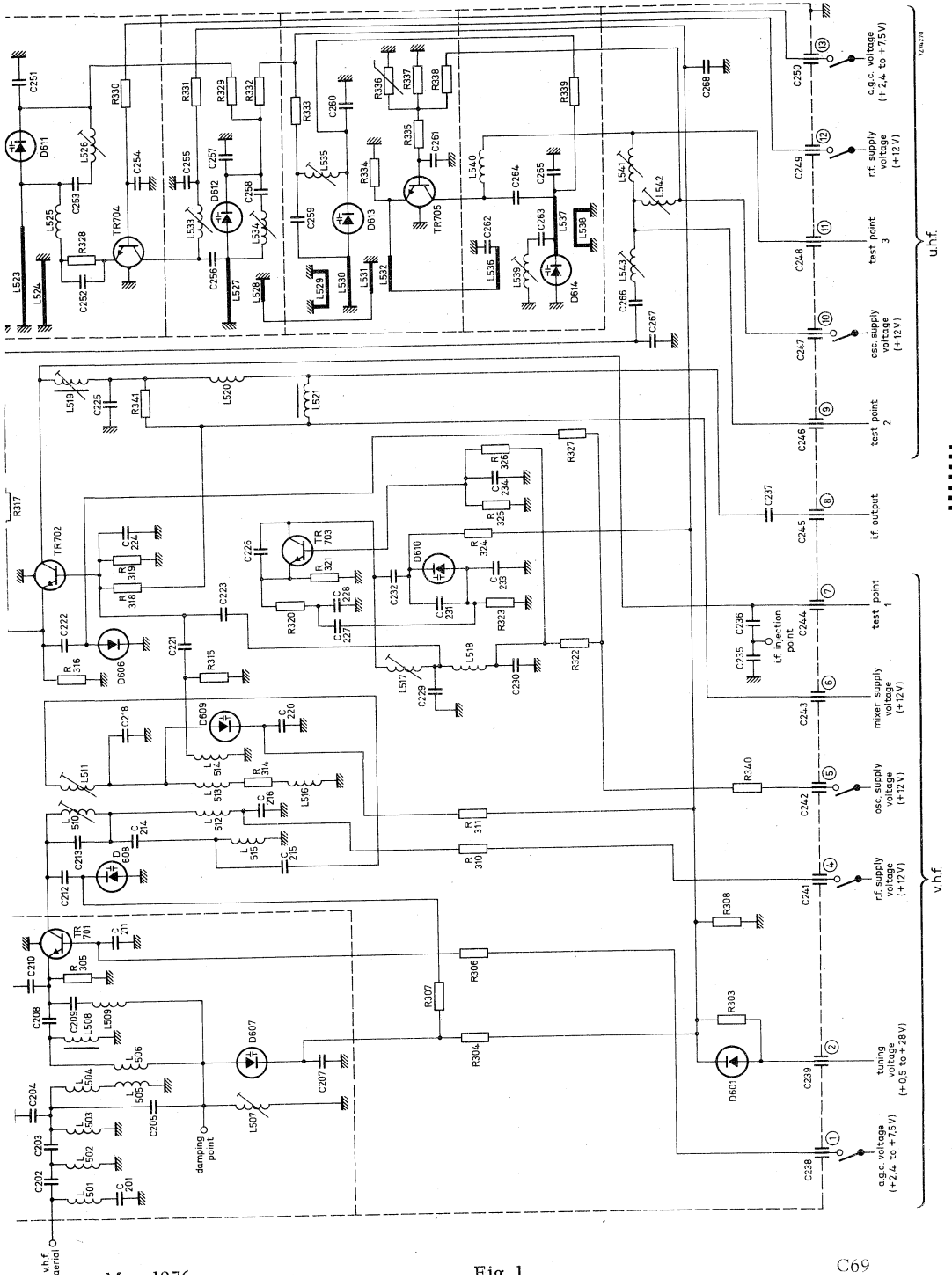
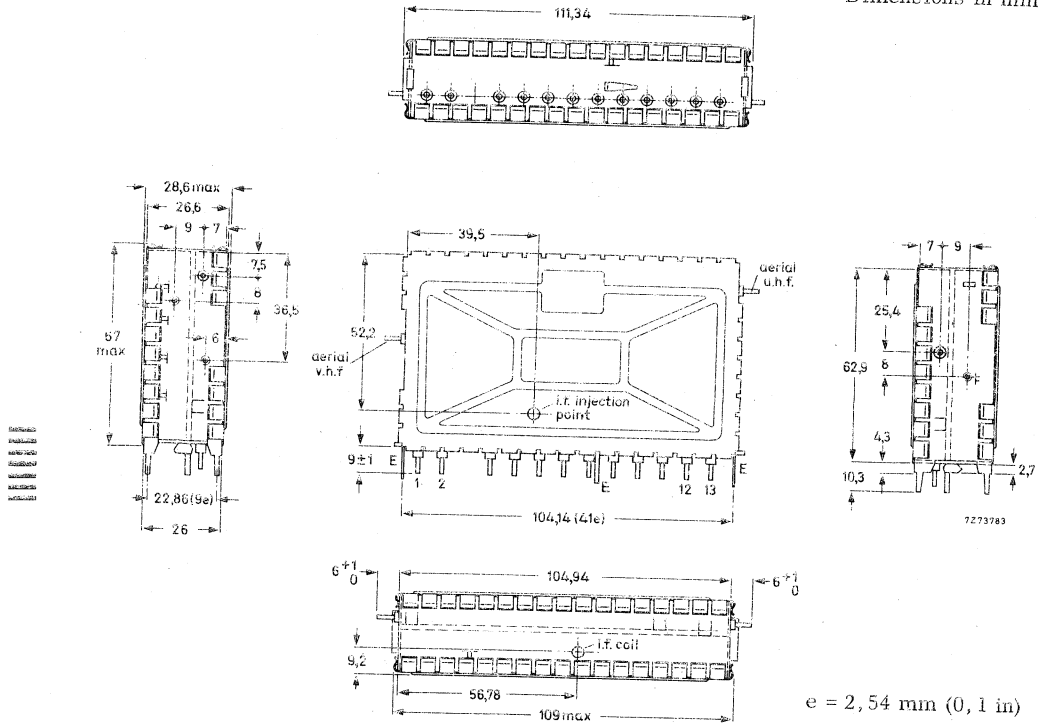

Fig 1

MECHANICAL DATA

Dimensions in mm



e = 2,54 mm (0,1 in)

Fig. 2

- Terminal 1 = a. g. c. voltage, v. h. f. , +2,4 to +7,5 V
- 2 = tuning voltage, +0,5 to +28 V
- 4 = r. f. supply voltage, v. h. f. , +12 V (approx. 3 to 10 mA)
- 5 = oscillator supply voltage, v. h. f. , +12 V (approx. 6 mA)
- 6 = mixer supply voltage, v. h. f. , +12 V (approx. 5 mA)
- 7 = test point 1, v. h. f.
- 8 = i. f. output
- 9 = test point 2 (alignment short)
- 10 = oscillator supply voltage, u. h. f. , +12 V (approx. 4,1 mA)
- 11 = test point 3, u. h. f.
- 12 = r. f. supply voltage, u. h. f. , +12 V (approx. 2,5 to 9,5 mA)
- 13 = a. g. c. voltage, u. h. f. , +2,4 to +7,5 V
- E = earth

Mounting

The tuner may be mounted by soldering it on to a printed-wiring board, using the piercing diagram shown in Fig. 3. (The tuner may also be mounted by means of a snap-in mount or a bracket. Information will be supplied upon request.)

The tuner may be mounted anywhere in the receiver and there are no restrictions on orientation.

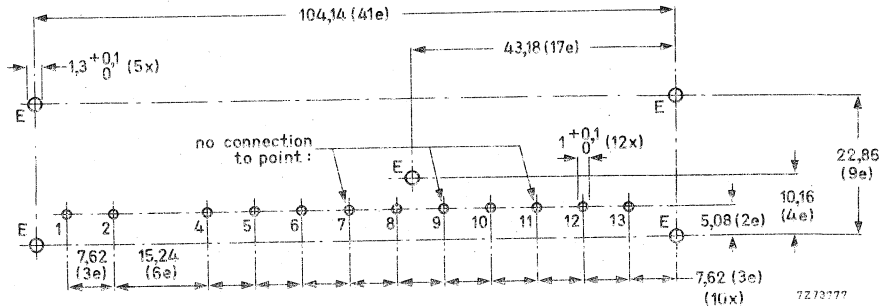

Fig. 3. Piercing diagram viewed from solder side of board; $e = 2.54$ mm (0,1 in).
No connection must be made to the points 7, 9 and 11, otherwise the oscillator radiation may increase.

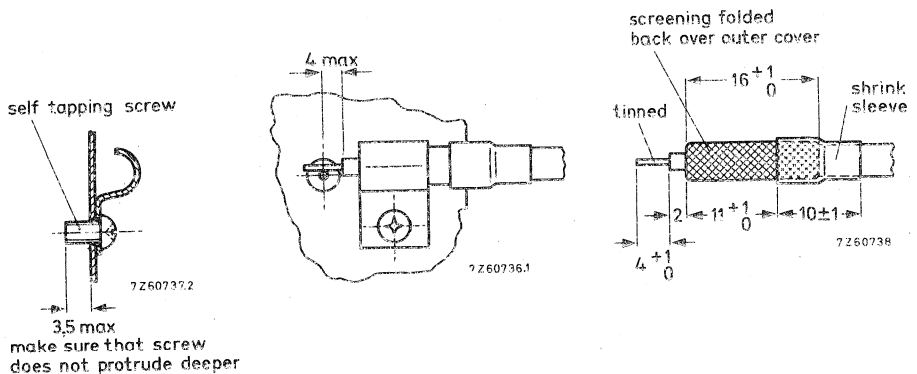

Fig. 4. Recommended fixing method of the aerial cables. Use a self-tapping screw.

ELECTRICAL DATA

Unless otherwise specified all electrical values apply at an ambient temperature of 25 ± 5 °C and a supply voltage of $12 \pm 0,3$ V.

Semiconductors

v. h. f. band, r. f. amplifier	BF200
mixer	BF182
oscillator	BF494
tuning diodes	4 x BB106
switching diode	BA243
u. h. f. band, r. f. amplifier	BF180
mixer/oscillator	BF181
tuning diodes	4 x BB105B
drift compensating diode	BAW62

Ambient temperature range

operating	+5 to +55 °C
storage	-25 to +85 °C

Supply voltage

Current drawn from +12 V supply

v. h. f. band	14 to 21 mA	} depending on a. g. c. voltage
u. h. f. band	11,5 to 18 mA	

A.G.C. voltage (Figs. 5 and 6)

v. h. f. band, at nominal gain	2,4 V
at 40 dB gain reduction	typ. 4,5 V
u. h. f. band, at nominal gain	2,4 V
at 30 dB gain reduction	typ. 5,0 V

A.G.C. current

v. h. f. band, at 40 dB gain reduction	max. 0,6 mA
u. h. f. band, at 30 dB gain reduction	max. 0,7 mA

Tuning voltage range (Fig. 7 and 8)

Current drawn from 28 V tuning voltage supply	+0,5 to +28 V max. 36 µA
--	-----------------------------

Frequency ranges

v. h. f. band	South African channel 4 (picture carrier 175,25 MHz) to channel 13 (picture carrier 247,43 MHz). Margin at the extreme channels: min. 2 MHz.
u. h. f. band	channel 21 (picture carrier 471,25 MHz) to channel 69 (picture carrier 855,25 MHz). Margin at the extreme channels: min. 3 MHz.

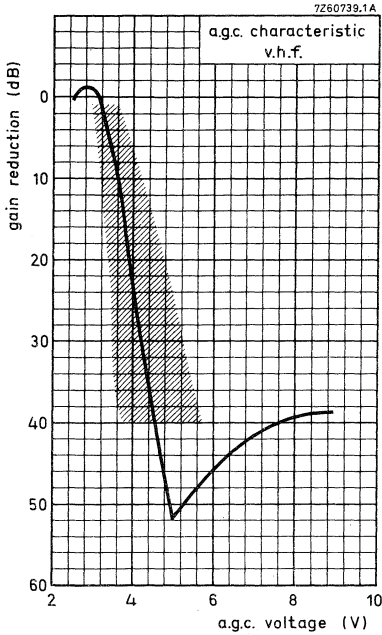

Fig. 5

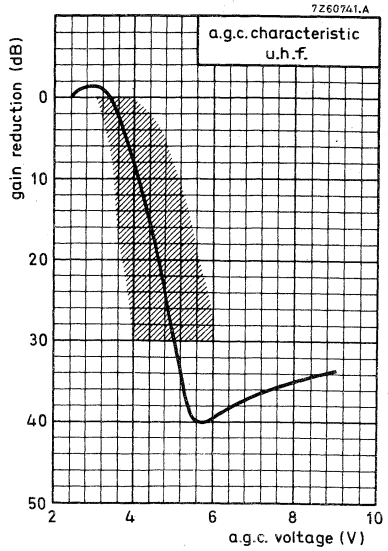

Fig. 6

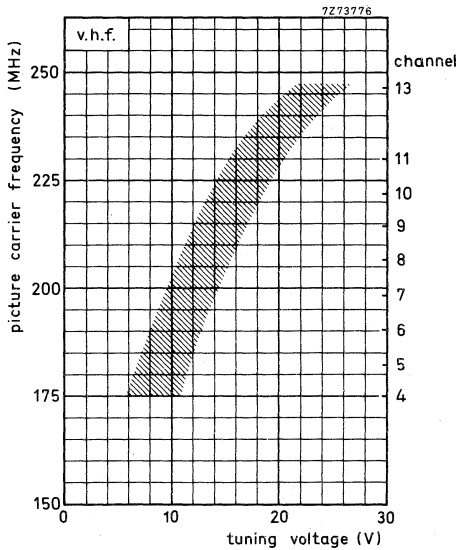

Fig. 7

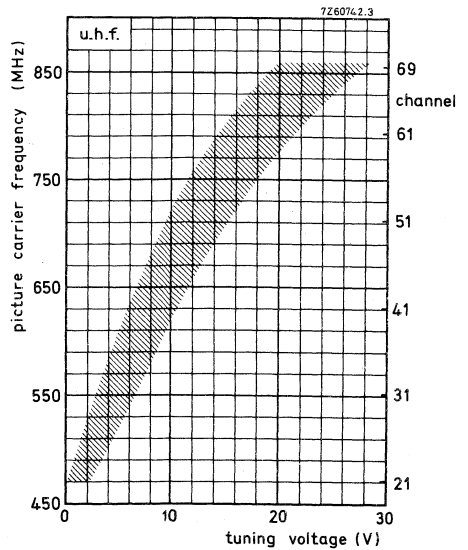

Fig. 8

Intermediate frequencies			
picture	38,9 MHz		
sound	32,9 MHz		
Input impedance			
asymmetrical	75 Ω		
symmetrical	300 Ω (see ACCESSORIES)		
V.S.W.R. (between picture carrier and sound carrier)			
	v. s. w. r. at nom. gain	max. v. s. w. r. during gain control	
	min. 1)	max. 2)	min. 1) max. 2)
v. h. f. band, channels 4 to 9	max. 3,5	max. 5	max. 4 max. 5
channels 10 to 13	max. 3,5	max. 6	max. 4 max. 6
u. h. f. band		max. 4	max. 5
A.G.C. range			
v. h. f. band	min. 40 dB		
u. h. f. band	min. 30 dB		
R. F. curves			
bandwidth, v. h. f. band	typ. 8 to 15 MHz		
u. h. f. band	typ. 15 to 25 MHz		
tilt, v. h. f. band	max. 3 dB		
u. h. f. band, channels 21 to 60	max. 3 dB		
channels 61 to 69	max. 4 dB		
Power gain (see also MEASURING METHOD OF POWER GAIN)			
v. h. f. band	min. 24 dB		
channel 4	typ. 28 dB		
channel 13	typ. 27 dB		
u. h. f. band	min. 25 dB		
channel 21	typ. 32 dB		
channel 31	typ. 29 dB		
channel 69	typ. 33 dB		
Noise figure			
v. h. f. band	max. 9 dB		
channel 9	typ. 6,5 dB		
u. h. f. band	max. 12 dB		
channel 21	typ. 8,0 dB		
channel 51	typ. 9,5 dB		
channel 69	typ. 10,5 dB		

1) Best value of V.S.W.R. between picture carrier and sound carrier.
2) Worst value of V.S.W.R. between picture carrier and sound carrier.

I. F. rejection			
v. h. f. band		min. 60 dB	
u. h. f. band		min. 60 dB	
Image rejection			
v. h. f. band		min. 60 dB	
u. h. f. band		min. 40 dB	
Signal handling (see also Figs. 10 and 11)			
Minimum input signal (e. m. f.) producing cross-modulation (1%) at nominal gain, in channel			
(wanted signal: picture carrier frequency, interfering channel: sound carrier frequency), v. h. f. band	typ.	4 mV	1)
u. h. f. band	typ.	5 to 10 mV	
in band			
(wanted signal: signal carrier frequency of channel N, interfering signal: picture carrier of channel N-2 (v. h. f.), N-5 (u. h. f.))			
v. h. f. band	typ.	10 to 50 mV	1)
u. h. f. band	typ.	15 to 50 mV	
Minimum input signal (e. m. f.) producing overloading, at nominal gain at maximum a. g. c.			
	typ.	10 mV	2)
	typ.	>200 mV	
Minimum input signal (e. m. f.) at nominal gain producing a shift of the oscillator frequency of 10 kHz, v. h. f. band	typ.	>25 mV	3)
u. h. f. band	typ.	10 to 20 mV	
Detuning of the i. f. output circuit as a result of band switching and tuning with respect of channel 7		max. 400 kHz	

¹⁾ This e. m. f. (open voltage) is referred to an impedance of 75 Ω .

1% cross-modulation means that 1% of the modulation depth of the interfering signal is transferred to the wanted signal.

²⁾ This e. m. f. (open voltage) is referred to an impedance of 75 Ω .

Criterion of overloading: 30% compression of the synchronization pulses of a standard television signal or a noticeable deterioration of the picture quality.

³⁾ This e. m. f. (open voltage) is referred to an impedance of 75 Ω .

Shift of oscillator frequency

at a change of the supply voltage of 10%

v. h. f. band

max. 300 kHz

u. h. f. band

max. 600 kHz

during warm-up time (measured between 5 s
and 15 min after switching on)

v. h. f. band

max. 100 kHz

u. h. f. band

max. 250 kHz

at a gain reduction of 30 dB

max. 100 kHz

Drift of oscillator frequency

at a change of the ambient temperature
from 25 to 40 °C

v. h. f. band

max. 400 kHz

u. h. f. band

max. 500 kHz

Oscillator radiation

The tuner is in conformity with the radiation requirements of C.I.S.P.R. Recommendation No. 24/3, provided the following conditions are fulfilled:

- A low-pass filter (Fig. 9) with a cut-off frequency of about 300 MHz has to be inserted between the v. h. f. aerial terminal of the tuner and the aerial terminal of the receiver. Television receivers with a common v. h. f. /u. h. f. connector in combination with a low-pass/high-pass splitter ¹⁾ may not need this additional filter.

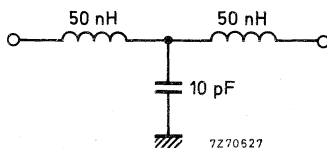

Fig. 9

- No connections must be made to the terminals 7, 9 and 11.
- Earthing of the tuner and connections to the i. f. amplifier have to be made in such a way, that additional radiation is prevented.

Microphonics

If the tuner is installed in a professional manner, there will be no microphonics.

¹⁾ E. g. coaxial aerial input assembly 3122 127 10450.

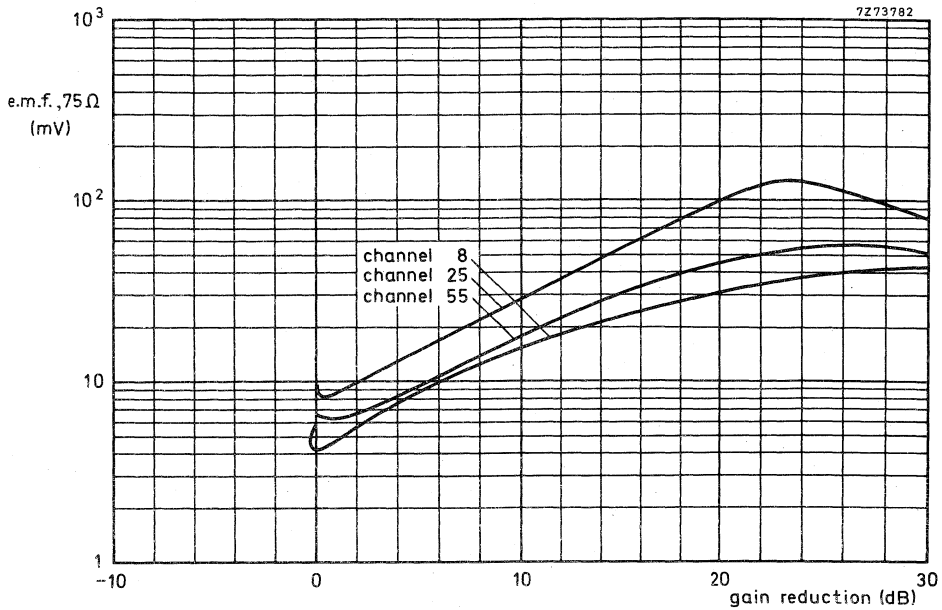

Fig. 10. Cross-modulation, in channel.

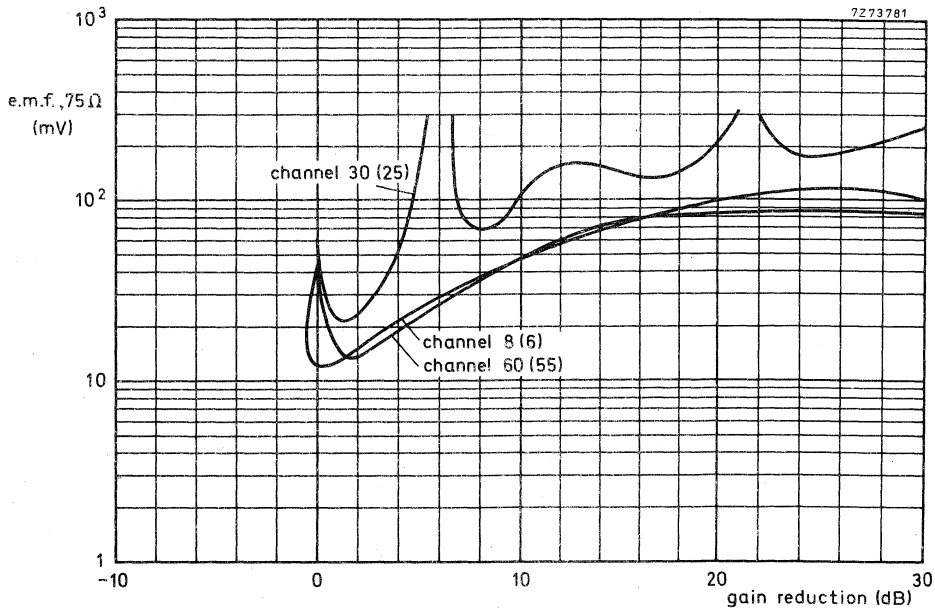

Fig. 11. Cross-modulation, in band; the interfering channels are given between brackets.

APPLICATION INFORMATION

Connection of the tuner

For connection of the tuner the terminal location, Fig. 2, should be consulted. If the tuner is used in receivers the chassis of which is connected to the mains, isolating capacitors according to the safety rules have to be inserted in the aerial leads. Three ways of connecting, depending on the number of switches available, are given below.

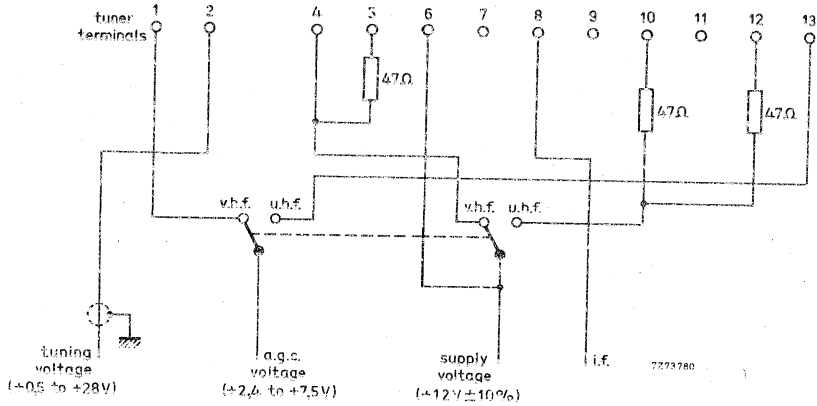

Fig. 12. Connection diagram with two switches.

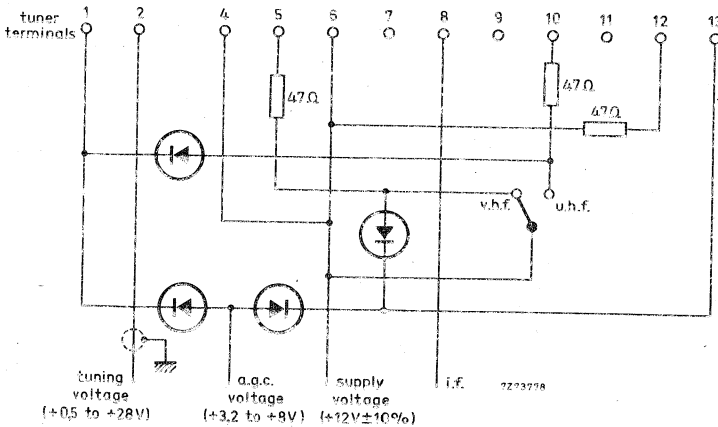

Fig. 13. Connection diagram with one switch.

All diodes: BAX13, BA217 or comparable silicon diodes.

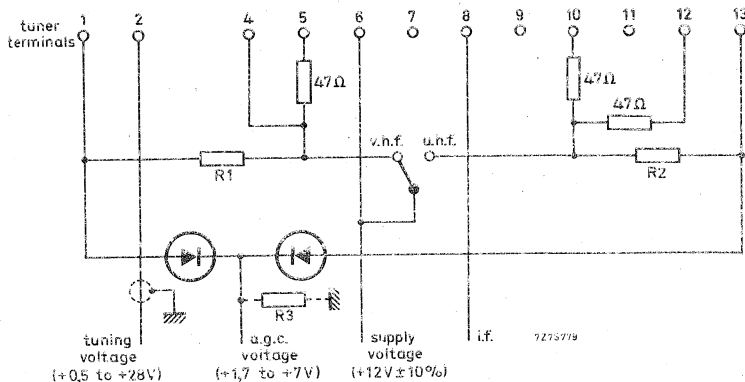

Fig. 14. Connection diagram with one switch.

All diodes : BAX13, BA217 or comparable silicon diodes.
The values of R_1 , R_2 and R_3 depend on a.g.c. circuit.

Alignment of the i.f. circuit

The tuner is provided with an i.f. injection point at the collector of the mixer for aligning the i.f. circuit together with the i.f. amplifier of the television receiver (for the position of the i.f. injection point see Fig. 2).

The aligning should be done with the v.h.f. band tuned. The tuning voltage should be 15 to 20 V.

If this injection method cannot be employed in the television receiver (e.g. because the injection point is not accessible or there is not enough i.f. signal available), the i.f. signal can be fed to test point 3 (terminal 11) via a capacitor of 0,82 to 1 pF. The tuner must be switched to the u.h.f. position; the tuning voltage should be approx. 10 V. This injection method requires approx. 14 dB less signal than the first method.

No permanent connection must be made to test point 3, otherwise the tuner may exceed the oscillator radiation limits.

MEASURING METHOD OF POWER GAIN

The i. f. output of the tuner should be terminated with the circuit given below.
The terminals 7, 9 and 11 should be not connected.

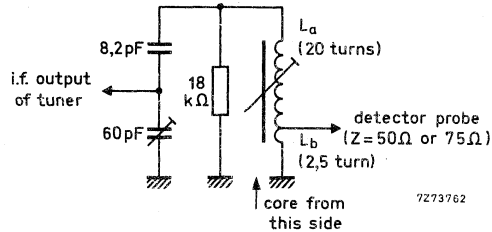

Fig. 15

Switch the tuner to the v. h. f. band; the tuning voltage should be 15 to 20 V.
Feed an i. f. sweep signal (500 to 1000 mV) to the i. f. injection point.
Adjust the trimmer (Fig. 15), tunable coil (L_a/L_b), i. f. output coil of the tuner L519 (Fig. 1) and the coupling between L_a and L_b to get the resonant curve as given below.

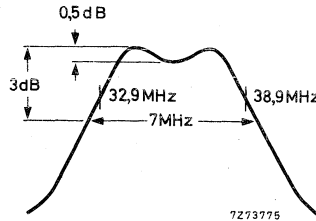

Fig. 16

Then display the r. f. + i. f. curve of the tuner at 190 MHz (picture carrier frequency) and make small corrections in the alignment of the i. f. coils (L_a/L_b and L519), if necessary, to get the markers 38,9 MHz and 32,9 MHz symmetrically on the slopes of the curve, and the peaks at equal amplitude.

Because the output impedance of the dummy circuit is 50 to 75 Ω , the power gain can be measured in the conventional manner by inserting tuner and dummy circuit between a 75 Ω source and a 75 Ω detector (or between a 50 Ω source and matching pad 50/75 Ω and a 50 Ω detector).

ACCESSORIES

aerial input transformer ELC1094, v. h. f., catalogue number : 2422 542 10941;
aerial input transformer ELC2092, u. h. f., catalogue number : 2422 542 12921;
coaxial aerial input assembly, catalogue number 3122 127 10450.

V.H.F. TELEVISION TUNER

with diode tuning

QUICK REFERENCE DATA	
Systems	C.C.I.R. systems M and N (R.T.M.A.)
Channels	A2 to A6 (low v.h.f. band) A7 to A13 (high v.h.f. band)
Intermediate frequencies	
picture	45,75 MHz
sound	41,25 MHz

APPLICATION

Designed to cover the v.h.f. channels of C.C.I.R. systems M and N (R.T.M.A.). Thanks to its good signal-handling properties, the tuner is especially suited for strong signal areas.

DESCRIPTION

The ELC3082 is a v.h.f. tuner with electronic tuning and band switching, covering the low v.h.f. band (frequency range 54 to 88 MHz) and the high v.h.f. band (frequency range 174 to 216 MHz).

Mechanically, the tuner is built on a low-loss printed-wiring board, carrying all components, in a metal housing made of a rectangular frame and front and rear cover (see Fig. 2). The aerial connection is on one of the frame sides, all other connections (supply voltages, a.g.c. voltage, tuning and switching voltages) are made via feed-through capacitors in the under side. The mounting method is shown in Figs. 3 and 4.

Electrically, the tuner consists of v.h.f. and i.f. parts. The aerial signal is fed to the input filters, providing i.f. rejection and band selection. The filters are followed by a P-I-N diode attenuator, equipped with two diodes BA379. The output of the attenuator is connected to the emitter of the input transistor BF480, operating as r.f. amplifier in grounded base configuration. The same transistor also delivers the current drive for the P-I-N diode attenuator, controlled by an a.g.c. voltage fed to the transistor base. The combination of the diode attenuator with this high current transistor (I_E at normal gain about 10 mA) has excellent signal-handling properties within the whole a.g.c. range.

The collector load of the input transistor is formed by a double tuned circuit, transferring the signal to the emitter of the mixer transistor BF324.

Good signal-handling properties of this stage are achieved by high oscillator injection. The oscillator is equipped with a transistor BF324. In the low v.h.f. position, self-detection of the oscillator signal is used to back-bias the five switching diodes BA243/244 (or BA182), required for band switching between low and high v.h.f. channels.

Three capacitance diodes BB106 provide tuning of the r.f. circuits.

The collector of the mixer transistor is connected to a single tuned i.f. resonant circuit (about 20 MHz bandwidth), the output of which is fed to the i.f. output stage, equipped with another transistor BF324 in grounded base configuration.

This stage has also been designed especially for good signal-handling properties. The collector load of the i.f. output transistor is formed by a single tuned i.f. circuit, at the low end of which the i.f. signal is capacitively coupled out of the tuner.

The tuner can be used in combination with a u.h.f. tuner. In this case the u.h.f. i.f. signal is fed to the emitter of the i.f. output transistor, which acts as i.f. amplifier for u.h.f. as well as for v.h.f.

The u.h.f. i.f. input terminal can be used as an i.f. injection point for aligning the i.f. output circuit together with the i.f. amplifier of the television receiver. For the same purpose a separate i.f. injection point has been provided at the collector of the mixer.

The tuner requires transistor supply voltages of +12 V, a switching voltage of +12 V, a.g.c. voltages, variable from +5 V (normal operating point) to about +2,5 V (maximum a.g.c.) and a tuning voltage, variable from +0,5 V to +28 V.

The aerial input of the tuner is asymmetrical. For use in symmetrical aerial systems, aerial transformers (baluns) are available (see ACCESSORY).

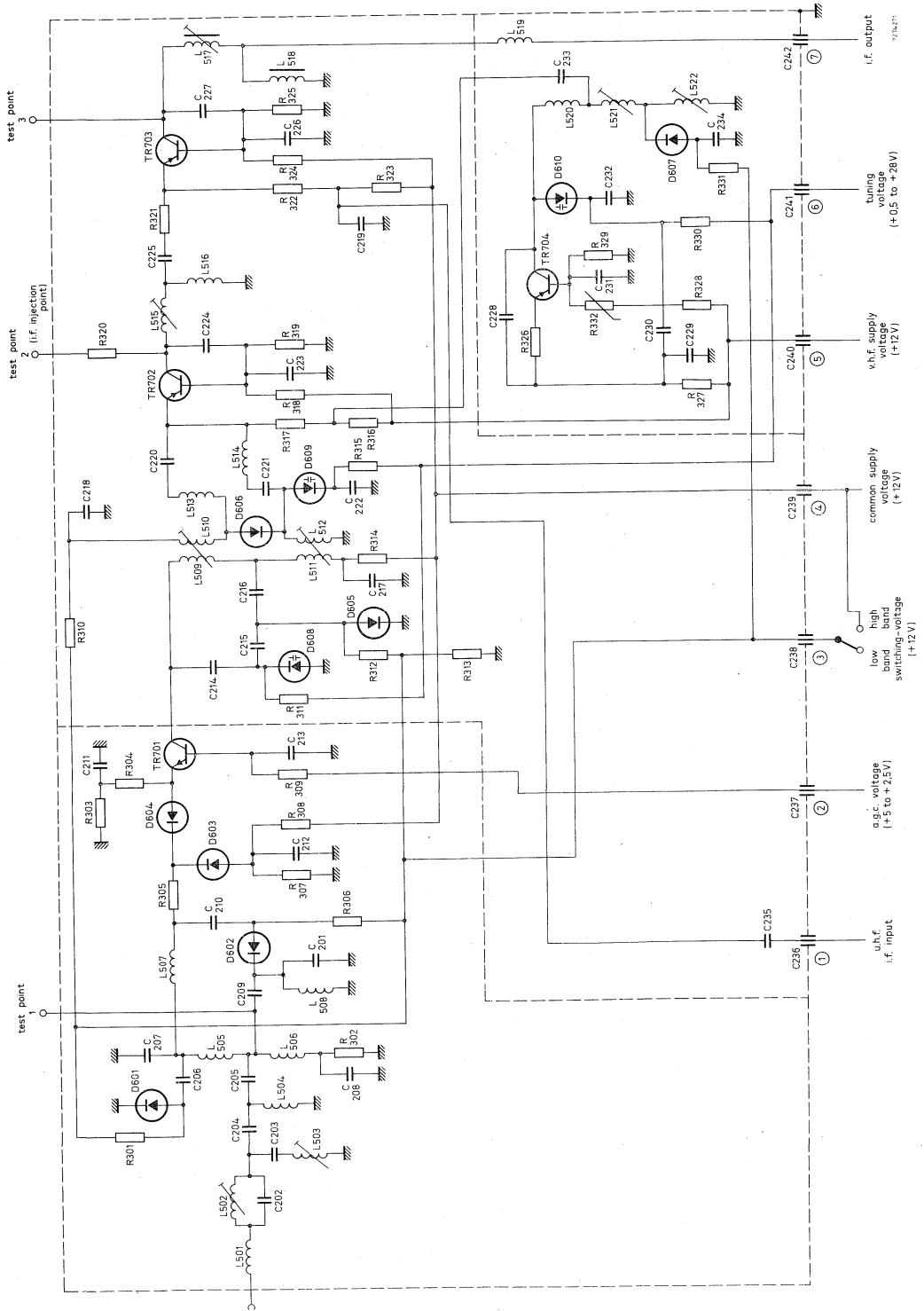

ELECTRICAL DATA

Unless otherwise specified all electrical values apply at an ambient temperature of 25 ± 5 °C and a supply voltage of $12 \pm 0,3$ V.

Semiconductors

P-I-N attenuator	2 x BA379
r. f. amplifier	BF480
mixer	BF324
oscillator	BF324
tuning diodes	3 x BB106
switching diodes	5 x BA243/244 (or BA182)
i. f. amplifier	BF324

Ambient temperature range

operating	+5 to +55 °C
storage	-25 to +85 °C

Supply voltage+12 V \pm 10%

Current drawn from +12 V supply at nominal gain

low band	46,5 mA \pm 10%
high band	63,5 mA \pm 10%

Notes - At 40 dB gain reduction the currents decrease about 5 mA.

- The supply voltage at terminal 4 should be carefully filtered to avoid hum modulation in one of the P-I-N diodes when the attenuator is biased to higher attenuation ratios. Under most unfavourable conditions a ripple voltage of 3 mV (p-p) may produce a disturbance which is just visible.

A. G. C. voltage (Figs. 5 and 6)

low band, at nominal gain	+5 \pm 0,2 V ¹⁾
at 40 dB gain reduction	+3,3 V (typical)
high band, at nominal gain	+5 \pm 0,2 V ¹⁾
at 40 dB gain reduction	+3,3 V (typical)

A. G. C. current

at nominal gain	max. 1 mA
with a. g. c.	max. 1 mA

Tuning voltage range (Figs. 7 and 8)

+0,5 to +28 V

Current drawn from 28 V tuning voltage supply

max. 0,5 μ A

Note - The source impedance of the tuning voltage, offered to terminal 6, must be max. 100 k Ω at tuning voltages below 5 V.

Switching voltage

low band	open circuit
high band	+12 V \pm 10%

Note - In the low band position the tuner produces a negative voltage (3 to 8 V) at terminal 3; this terminal must not be loaded with an external resistance below 50 M Ω .

¹⁾ This value may be increased to 5,5 V if a certain deterioration of signal handling is accepted. At voltages above 5,5 V the cross-modulation in band may deteriorate rapidly.

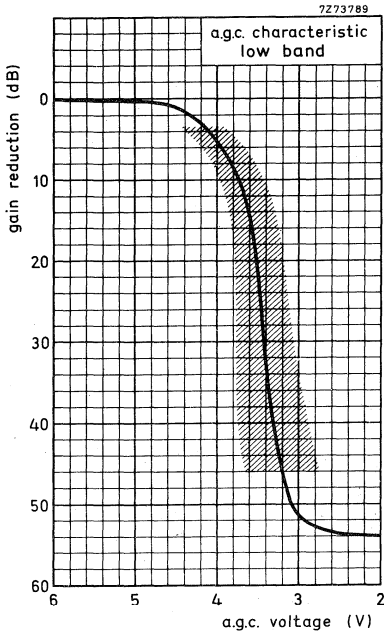

Fig. 5

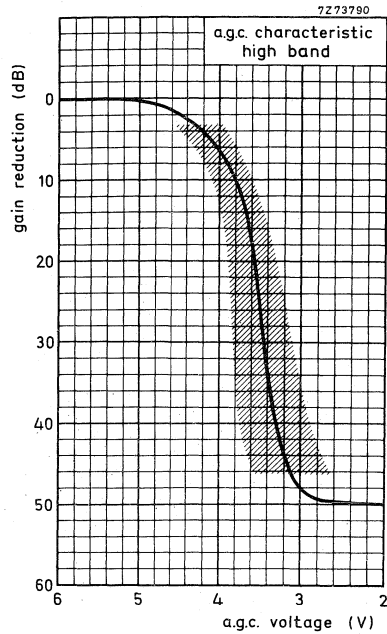

Fig. 6

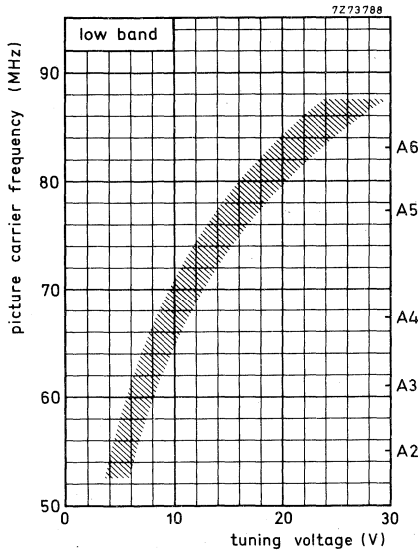

Fig. 7

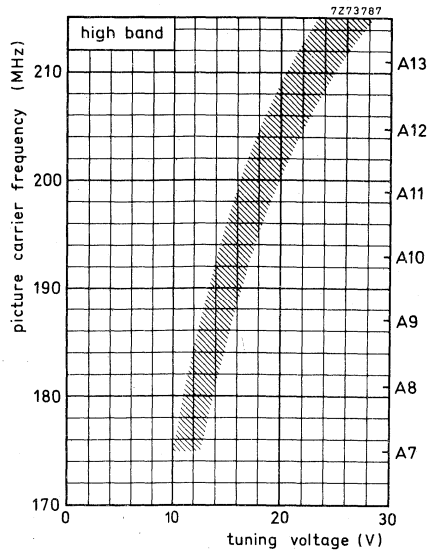

Fig. 8

Frequency ranges			
low band	channel A2 (picture carrier 55, 25 MHz) to channel A6 (picture carrier 83, 25 MHz). Margin at the extreme channels : min. 2 MHz.		
high band	channel A7 (picture carrier 175, 25 MHz) to channel A13 (picture carrier 211, 25 MHz). Margin at the extreme channels : min. 3 MHz.		
Intermediate frequencies			
picture	45, 75 MHz		
sound	41, 25 MHz		
Input impedance			
asymmetrical	75 Ω		
symmetrical	300 Ω (see ACCESSORY).		
V. S. W. R. (between picture carrier and sound carrier)	v. s. w. r. at nom. gain	max. v. s. w. r. during gain control	
low band	max. 3, 5	max. 3, 5	
high band	max. 4	max. 4	
A. G. C. range			
low band	min. 40 dB (typ. 54 dB)		
high band	min. 40 dB (typ. 50 dB)		
R. F. curves			
bandwidth, low band	typ. 7 to 10 MHz		
high band	typ. 8 to 10 MHz		
tilt, low band	max. 3 dB		
high band	max. 3 dB		
Power gain (see also MEASURING METHOD OF POWER GAIN)			
low band	min. 24 dB		
channel A2	typ. 27 dB		
channel A6	typ. 29 dB		
high band	min. 25 dB		
channel A7	typ. 28 dB		
channel A13	typ. 31 dB		
Noise figure			
low band	max. 9, 5 dB (typ. 7 dB)		
high band	max. 9, 5 dB (typ. 7, 5 dB)		
I. F. rejection			
low band, channel A2	min. 54 dB		
channel A3	min. 57 dB		
channels A4 to A6	min. 60 dB		
high band	min. 60 dB		

Image rejection		
low band	min. 56 dB	
high band	min. 50 dB	
Signal handling		
Minimum input signal (e. m. f.) producing cross-modulation (1%) in channel	max. gain	with a. g. c.
wanted signal: picture carrier frequency, interfering channel: sound carrier frequency in band	typ. 20 mV	typ. > 500 mV
wanted signal: picture carrier frequency of channel N, interfering signal: picture carrier of channel $N \pm 2$	typ. 100 mV	typ. > 500 mV
interfering signal: picture carrier of channel $\geq N \pm 3$	typ. 250 mV	typ. > 500 mV
Minimum input signal (e. m. f.) producing overloading, at nominal gain at maximum a. g. c.	typ. 50 mV typ. > 500 mV	} 2)
Minimum input signal (e. m. f.) at nominal gain producing a shift of the oscillator frequency of 10 kHz. low band	typ. 50 mV	} 3)
high band	typ. 30 mV	
Detuning of the i. f. output circuit as a result of band switching and tuning	max. 150 kHz	
Shift of oscillator frequency at a change of the supply voltage of 5%		
low band	max. 300 kHz	
high band	max. 300 kHz	
during warm-up time (measured between 5 s and 15 min after switching on)		
low band	max. 150 kHz	
high band	max. 150 kHz	

¹⁾ This e. m. f. (open voltage) is referred to an impedance of 75Ω .
1% cross-modulation means that 1% of the modulation depth of the interfering signal is transferred to the wanted signal.

²⁾ This e. m. f. (open voltage) is referred to an impedance of 75Ω .
Criterion of overloading: 30% compression of the synchronization pulses of a standard television signal or a noticeable deterioration of the picture quality.

³⁾ This e. m. f. (open voltage) is referred to an impedance of 75Ω .

Drift of oscillator frequency
at a change of the ambient temperature
from 25 to 50 °C

low band

max. 500 kHz

high band

max. 500 kHz

Oscillator radiation

The tuner is in conformity with the radiation requirements of C. I. S. P. R. Recommendation No. 24/2 and the corresponding F. C. C. rules, provided the tuner is installed in a professional manner.

Microphonics

If the tuner is installed in a professional manner, there will be no microphonics.



ALIGNMENT OF THE I.F. CIRCUIT

For i.f. injection the u.h.f. i.f. input (terminal 1) or the i.f. injection point at the collector of the mixer transistor (at the top of the tuner, Fig. 2) can be used. The aligning can be done with any channel tuned. A probe as shown in Fig. 9 should be used.

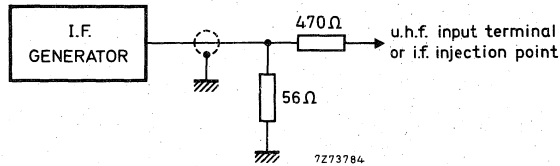

Fig. 9

The signal attenuation between the i.f. generator and the i.f. output of the tuner is about 4 dB when injection is done via the injection point, and about 8,5 dB in the case of injection via the u.h.f. i.f. input.

The i.f. output circuit is detuned about +300 kHz¹⁾ or -150 kHz¹⁾ when injection is done via the injection point or via the u.h.f. i.f. input respectively.

MEASURING METHOD OF POWER GAIN

The i.f. output of the tuner should be terminated with the RC-circuit given in Fig. 10.

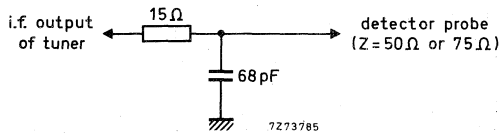

Fig. 10

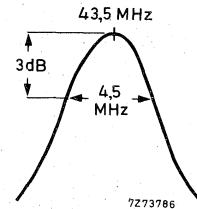

Fig. 11

The RC-circuit roughly matches the i.f. output impedance to 75Ω at the resonant frequency of the i.f. output circuit, which should be tuned to 43,5 MHz. The bandwidth should be approx. 4,5 MHz.

Because the input and output impedances of the tuner are now 75Ω, the power gain can be measured in the conventional manner by inserting tuner and RC-circuit between a 75Ω source and a 75Ω detector (or between a 50Ω source and matching pad 50/75Ω and a 50Ω detector).

ACCESSORY

Aerial input transformer ELC1094, v. h. f. , catalogue number : 2422 542 10941.

¹⁾ Reference: normal operation with r.f. signal via aerial input.

V.H.F. AND U.H.F. TELEVISION TUNERS with diode tuning

INTRODUCTION

Television tuners 12ET5732 and 12ET5632 have been developed for the reception of television signals in v.h.f. bands I and III and u.h.f. bands IV and V respectively (C.C.I.R. system). The tuners may be used together or separately. Tuning is achieved by variable capacitance diodes.

The input circuits of the tuners can be connected in parallel to the aerial via 75 Ω coaxial cable. The i.f. outputs may also be connected in parallel. Selection of v.h.f. or u.h.f. reception is effected by switching the operating voltage.

Tuning of channels 2 to 12 is done by altering the tuning voltage and automatically omitting the range between channels 4 and 5 (band II).

The tuners may be mounted directly on to a printed-wiring board (see paragraph "Mounting" of the relevant tuner) but it is advisable to use the mounting socket shown in Fig. 2 to facilitate repair.

Fig. 1 Example of connecting a potentiometer unit with a push-button unit.

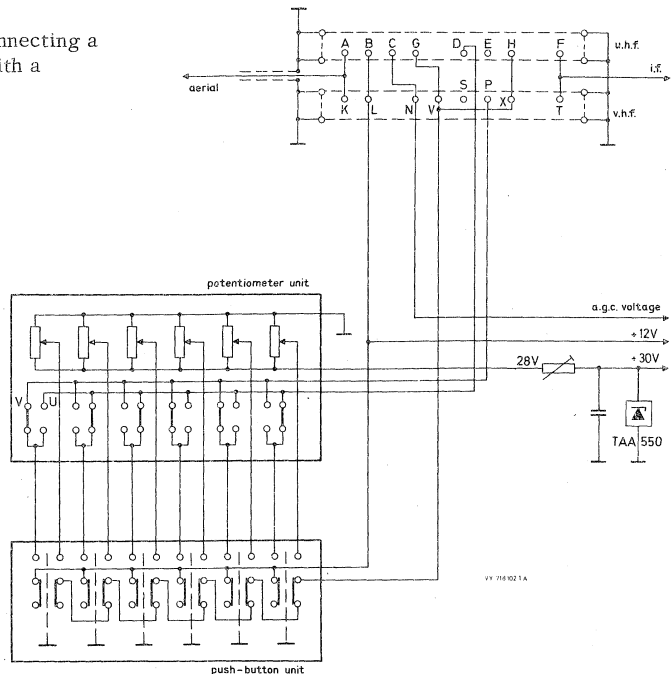

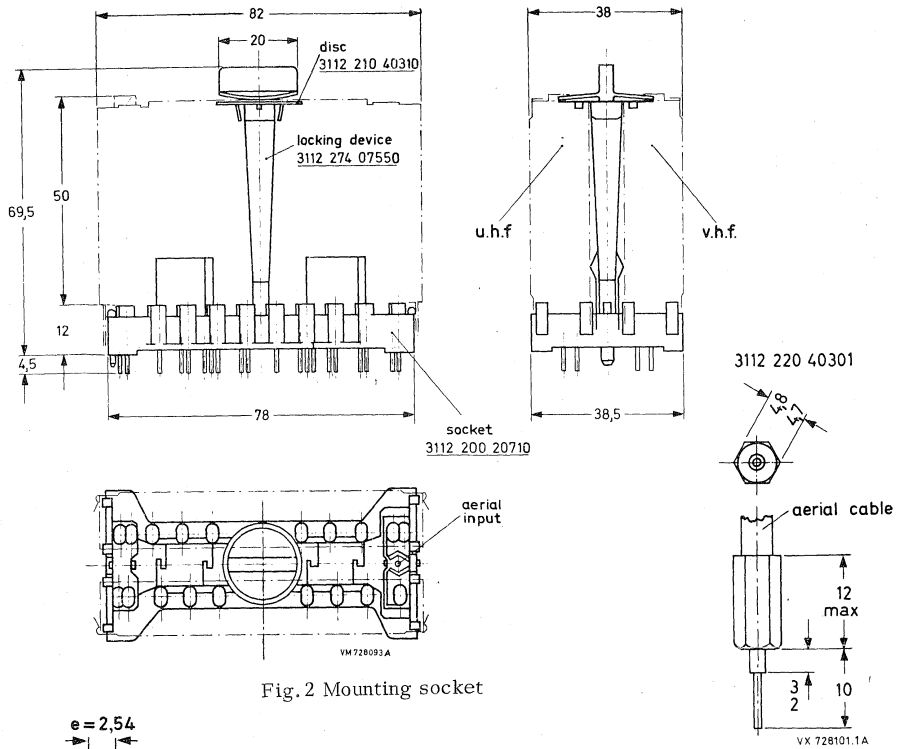

Fig. 2 Mounting socket

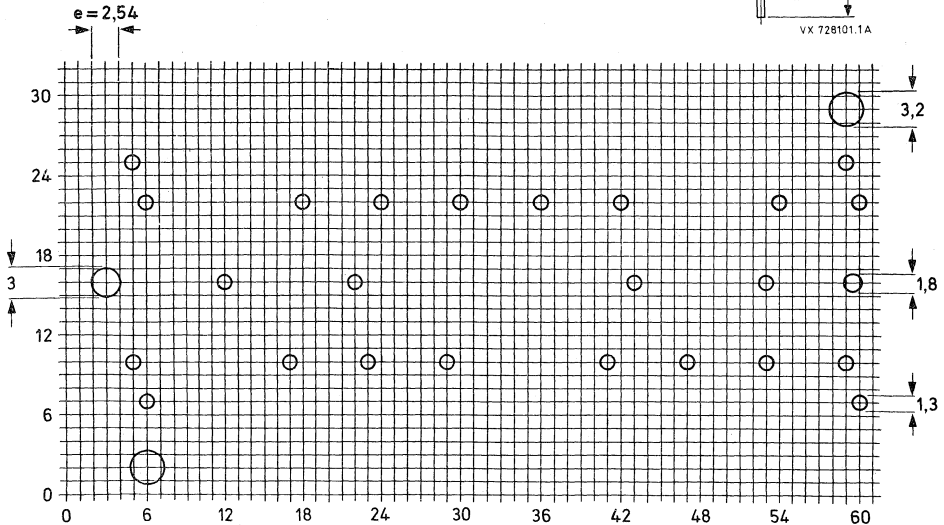

Fig. 3 Hole pattern of the printed-wiring board for the mounting socket (viewed on solder side).

CONNECTING THE I. F. OUTPUTS

As it is possible to connect the i. f. outputs of the tuners in parallel, the following must be noted.

The i. f. outputs should be connected to the i. f. amplifier via the network shown in Fig. 4. The quality of each i. f. circuit is adjusted to the same (highest possible) value to ensure that the network has the same effect on both circuits. If this were not done, switching from v. h. f. to u. h. f. might not cause the correct change in i. f. and bandwidth of the adjusted bandpass curve. Damping resistor R_B (0 to 56 Ω), connected between the tuners and the network, makes it possible to adjust the bandwidth of the i. f. tuner circuits between (approx.) 2, 2 MHz and 3, 8 MHz.

Mixer transistors T_2 (u. h. f.) and T_{43} (v. h. f.) have a common collector resistor of 470 Ω (R_C). The mixer transistor in use causes a potential difference of between 0, 8 V and 1 V across R_C and, as a result, the collector/base diode of the non-operating mixer transistor is influenced. In this way the base capacitor will be connected in parallel with the i. f. circuit. The circuit is thus detuned in such a way that it does not affect the bandpass curve of the i. f. filter in use.

Collector resistor R_C is decoupled by coil L_E which means that capacitor C_K is not damped and the bandpass curve shows no deterioration.

Capacitor C_T prevents d. c. potentials from being applied to the i. f. amplifier should an electrical connection exist to earth or to the transistor.

The component values of the network between the tuners and the i. f. amplifier are not critical, some of the components may even be omitted provided that their influence is taken into account when calculating the i. f. amplifier input.

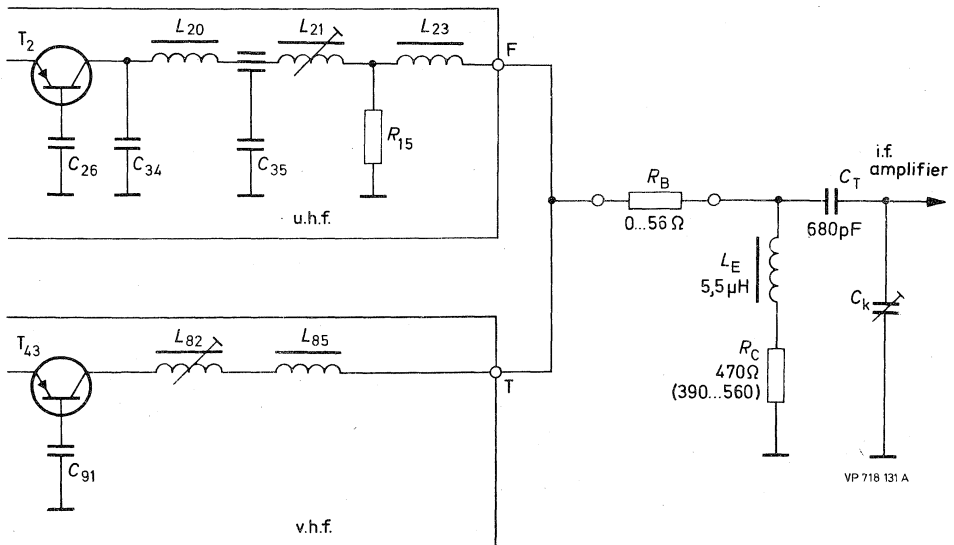

Fig. 4

ALIGNMENT OF THE I. F. CIRCUIT

To adjust the i. f. bandpass curves, the tuners should be inserted into the mounting socket and their i. f. outputs connected to the i. f. amplifier as shown in Fig. 4.

Adjustment is done at supply voltage = 12 V,
a. g. c. voltage = 6 V,
tuning voltage = 10 V.

The wobble generator signal (connected via 75 Ω) is connected to the i. f. injection points S and E.

Switch to u. h. f. reception and adjust i. f. coil L_{21} to obtain the desired bandpass curve; switch to v. h. f. and similarly adjust i. f. coil L_{82} . It is advisable to repeat these adjustments as a check.

The following dummy circuit (Fig. 4) can be used to check the tuner without an i. f. amplifier, and to pre-adjust the i. f. circuit.

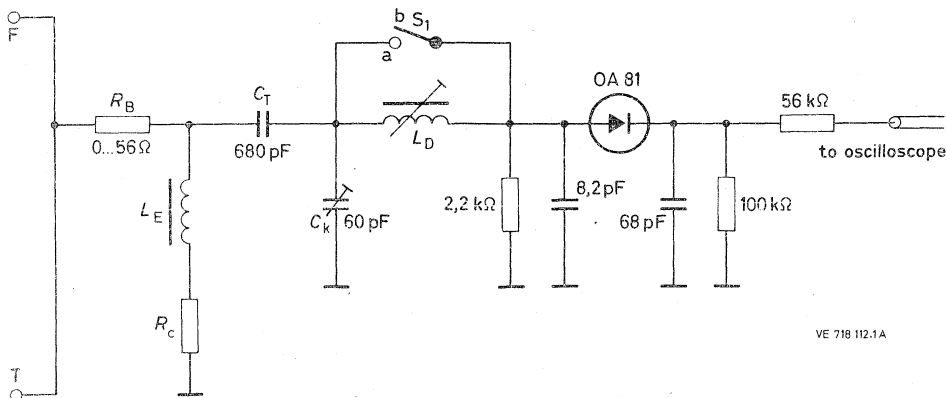

Fig. 5

With S_1 open and $R_B = 0 \Omega$, the i. f. circuit of the tuner, and the dummy circuit L_D , can be adjusted to a bandpass filter having the curve shown in Fig. 6. Switch S_1 has to be closed to display the bandpass curve of the tuner i. f. circuit (without dummy circuit L_D).

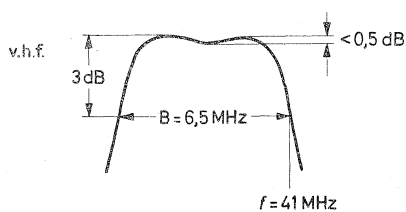

Fig. 6a

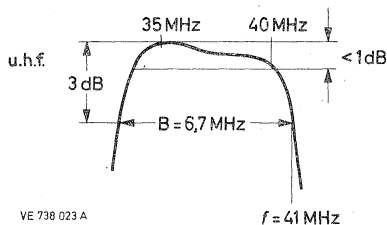

Fig. 6b

U.H.F. TELEVISION TUNER with diode tuning

QUICK REFERENCE DATA	
System	C. C. I. R. , system G
Channels	E21 to E68 (bands IV and V)
Intermediate frequencies	
picture	38,9 MHz
sound	33,4 MHz

APPLICATION

This all-electronic television tuner has been developed for reception of television signals in the bands IV and V (C. C. I. R. system G).

MECHANICAL DATA

Dimensions in mm

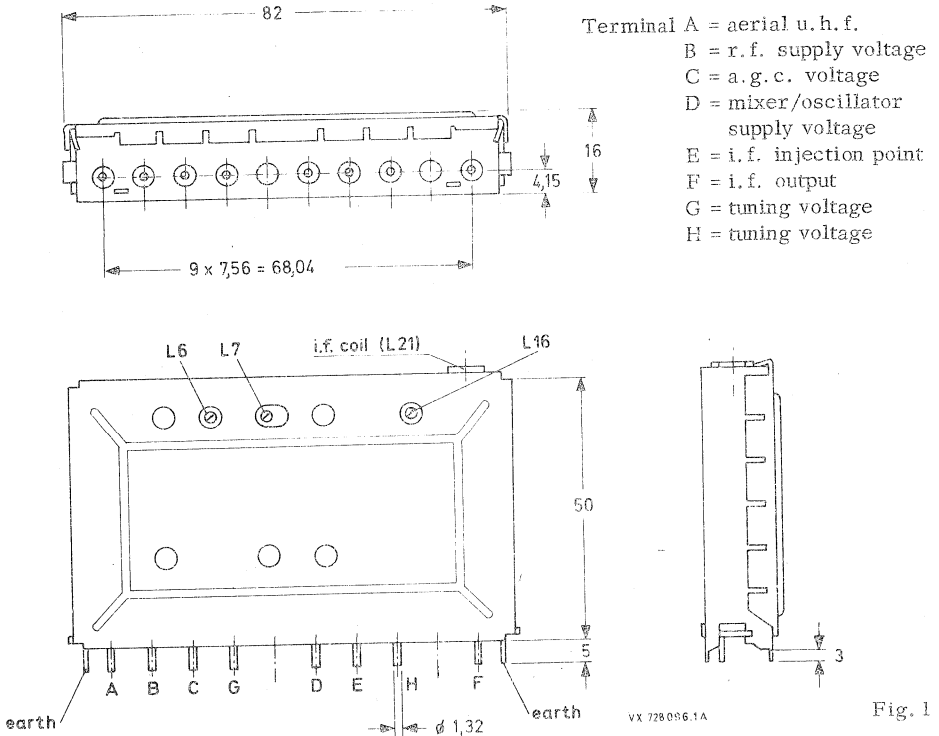

Fig. 1

Mounting

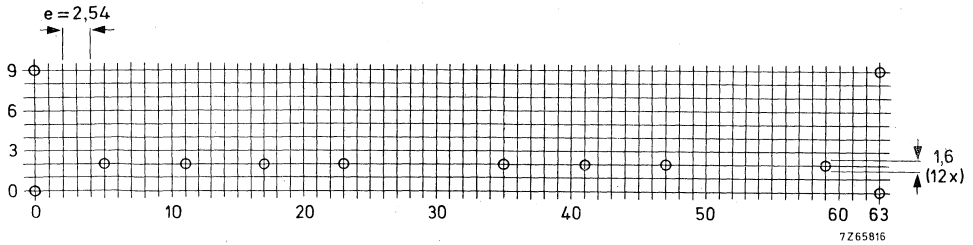

Fig. 2 Hole pattern of the printed-wiring board (viewed on solder side).



ELECTRICAL DATA

Semiconductors,	
r.f. amplifier	AF367
mixer/oscillator	AF367
tuning diodes	3 x BB105B
Ambient temperature range	
operating	+10 to +50 °C
storage	-25 to +60 °C
Supply voltage	+12 V, ± 10%
Current drawn from +12 V supply	6,5 to 12 mA (depending on a.g.c. voltage)

A.G.C. voltage range (Figs. 5, 6, 7 and 8)

9, 8 to 2 V

For the adjustment of the a.g.c. voltage, the circuit shown below can be used

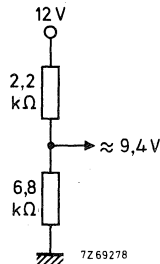

Fig. 3

Tuning voltage range (Fig. 4)

0,5 to 28 V

Frequency range, channel E21 to E68

471,25 to 847,25

Margin at the extreme channels
≥ 1 MHz (typical value: 2 MHz)

Intermediate frequencies

picture
sound

38,9 MHz

33,4 MHz

The oscillator frequency is higher than the signal frequency

Input impedance

75 Ω

Power gain

≥ 20 dB (typical value: 23 dB)

Noise figure

≤ 10 dB (typical value: 7,5 dB)

Gain reduction

≥ 30 dB (typical value: 40 dB)

Reflections

≤ 50%

I.F. rejection

≥ 60 dB (typical value: 65 dB)

Image frequency rejection

≥ 36 dB (typical value: 45 dB)

Cross modulation

an interfering signal of 15 mV (channel $X \pm 2$) at the 75Ω aerial input produces no visible cross modulation on the wanted signal (channel X), independent of the adjustment of the r. f. transistor

Shift of oscillator frequency at a change of the supply voltage of $\pm 10\%$

≤ 500 kHz

during warm-up time (30 s after switching on)

≤ 50 kHz

Drift of oscillator frequency at a change of the ambient temperature from 25 to 40 °C, channels 21 to 60
channels 61 to 68

≤ 400 kHz

≤ 600 kHz

Tuning range of i. f. coil

32 to 40 MHz

Oscillator radiation

the tuner is in conformity with the radiation requirements of IEC 106 and of CISPR24/3.

Lightning protection

the tuner is insensitive to lightning discharges of 30 kV, 400 mWs applied to the aerial input for up to 30 s at a repetition frequency of 1 to 20 Hz.

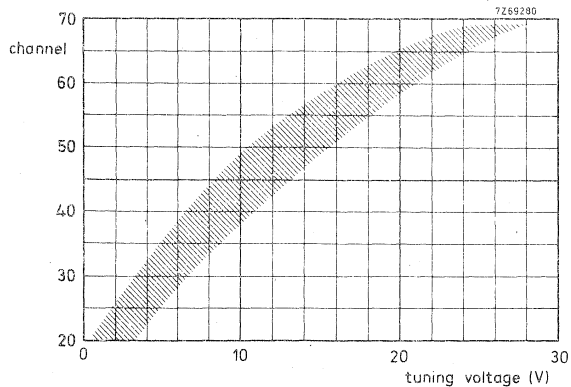

Fig. 4.

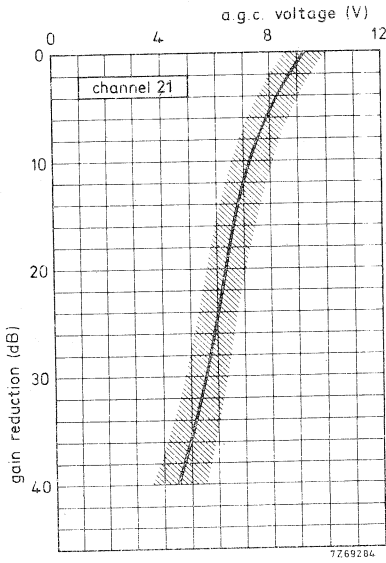

Fig. 5.

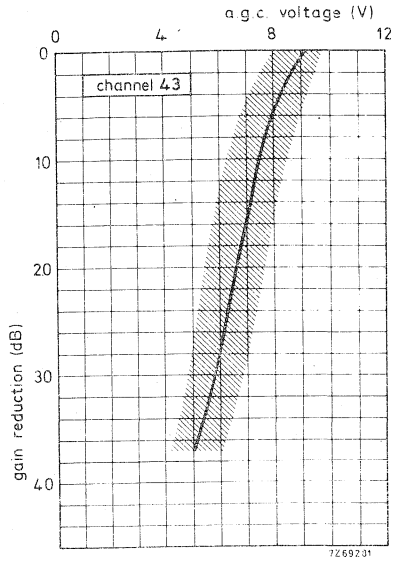

Fig. 6.

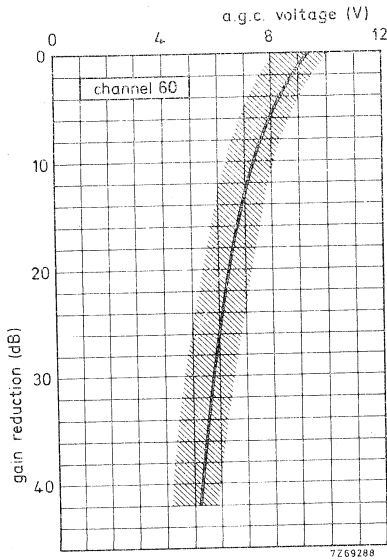

Fig. 7.

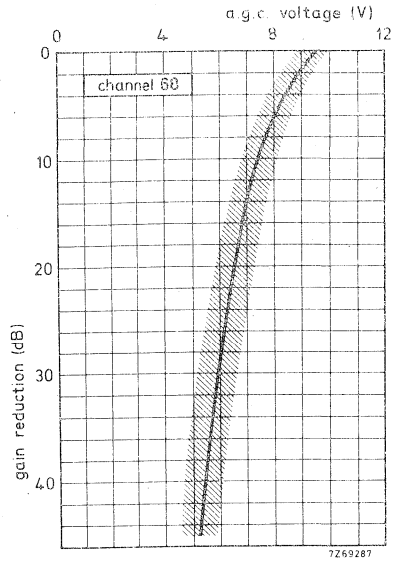

Fig. 8.

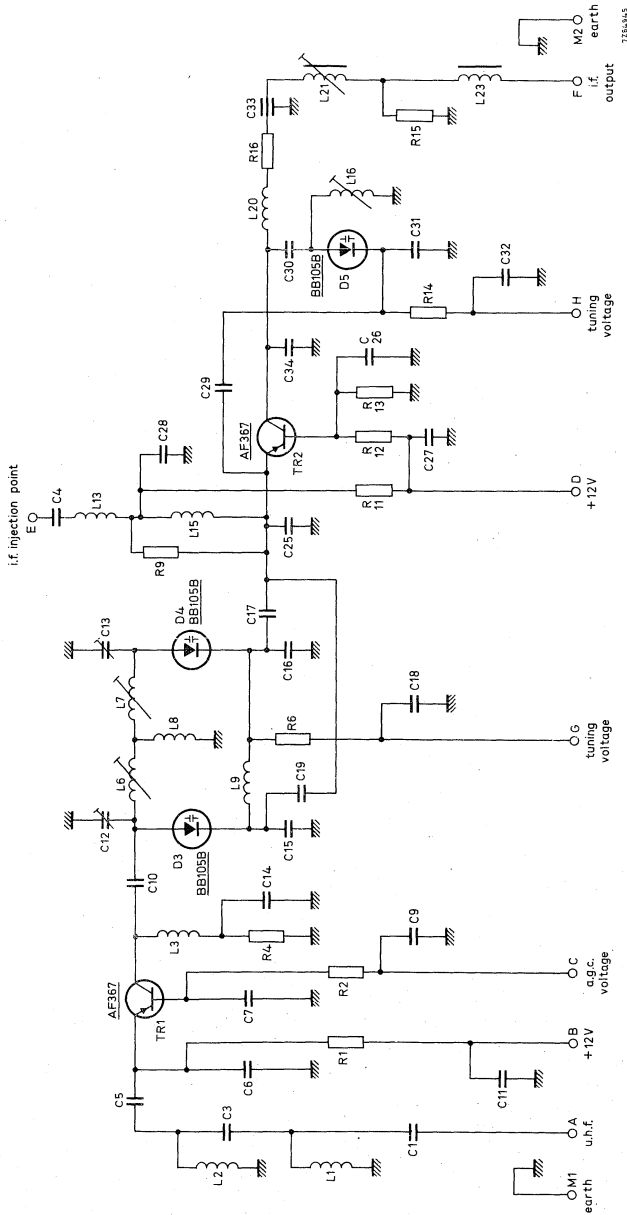

Fig. 9.

V.H.F. TELEVISION TUNER

with diode tuning

QUICK REFERENCE DATA	
System	C. C. I. R. , system B
Channels	E2 to E4 (band I) E5 to E12 (band III)
Intermediate frequencies	
picture	38,9 MHz
sound	33,4 MHz

APPLICATION

This all-electronic television tuner has been developed for reception of television signals in the bands I and III (C. C. I. R. system B).

MECHANICAL DATA

Dimensions in mm

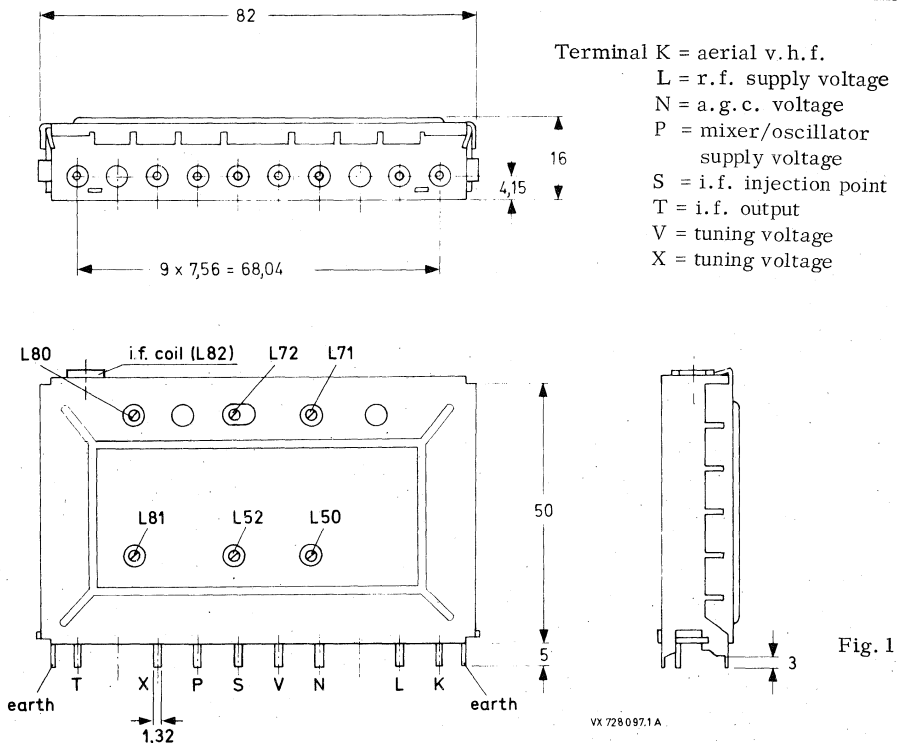

Mounting

Fig. 2 Hole pattern of the printed-wiring board (viewed on solder side).

12ET5732/03
9012 745 73203
C104

ELECTRICAL DATA

Semiconductors, r. f. amplifier mixer/oscillator tuning diodes	2 x AF367 AF367 6 x BB105G
Ambient temperature range operating storage	+10 to +50 °C -25 to +60 °C
Supply voltage	+12 V
Current drawn from +12 V supply	11,5 to 23,5 mA (depending on a. g. c. voltage)
A. G. C. voltage range (Figs. 5 to 8)	9,8 to 2 V For the adjustment of the a. g. c. voltage, the circuit shown below can be used

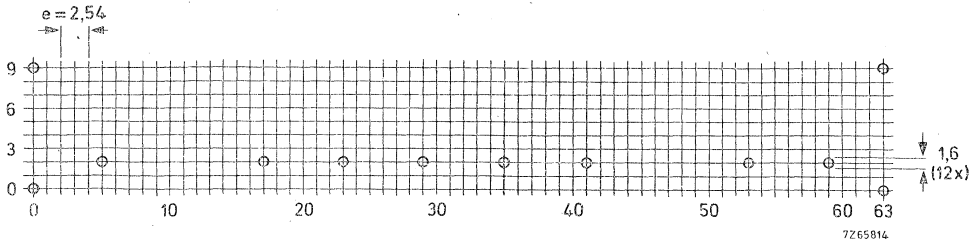
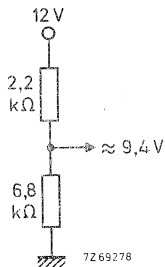

Fig. 3

Tuning voltage range (Fig. 4)	0,5 to 28 V
Frequency range	band I 48,25 to 62,25 MHz band III 175,25 to 224,25 MHz Margin at the extreme channels ≥ 1 MHz (typical value: 1,5 MHz)
Intermediate frequencies picture sound	38,9 MHz 33,4 MHz The oscillator frequency is higher than the signal frequency
Input impedance	75 Ω
Power gain	≥ 20 dB (typical value: 24 dB)
Noise figure	≤ 8,5 dB (typical value: 6 dB)
Gain reduction	≥ 28 dB (typical value: 36 dB)
Reflections	≤ 50 %
I. F rejection	≥ 50 dB (typical value: 57 dB)
Image frequency rejection	≥ 40 dB (typical value: 57 dB)

Cross modulation

an interfering signal of 15 mV (channel $X \pm 2$) at the 75Ω aerial input produces no visible cross modulation on the wanted signal (channel X) independent of the adjustment of the r.f. transistors.

Shift of oscillator frequency at a change of the supply voltage of $\pm 10\%$ ≤ 250 kHz

during warm-up time (30 s after switching on)

 ≤ 50 kHz

Drift of oscillator frequency at a change of the ambient temperature from 25 to 40 °C

 ≤ 400 kHz

Tuning range of i.f. coil

32 to 40 MHz

Oscillator radiation

the tuner is in conformity with the radiation requirements of IEC 106 and of CISPR24/3.

Lightning protection

the tuner is insensitive to lightning discharges of 30 kV, 400 mWs applied to the aerial input for up to 30 s at a repetition frequency of 1 to 20 Hz.

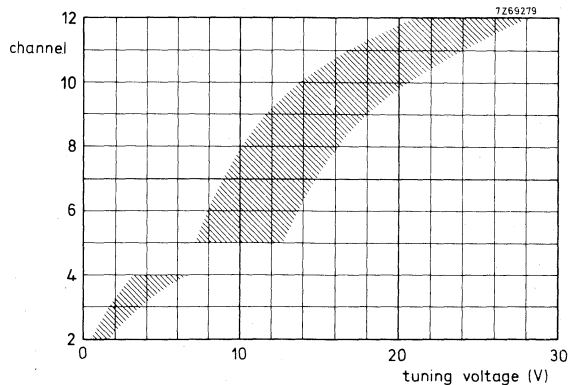

Fig. 4

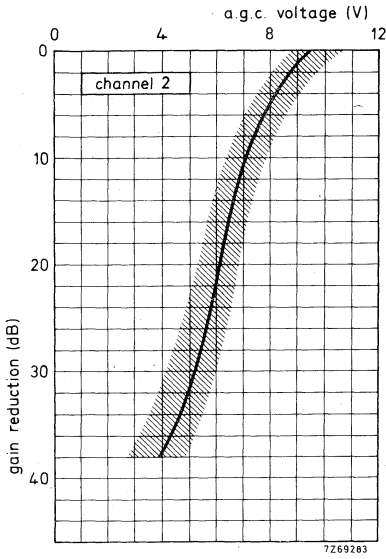

Fig. 5.

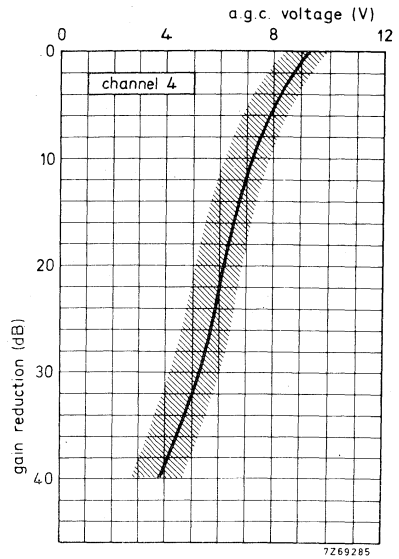

Fig. 6.

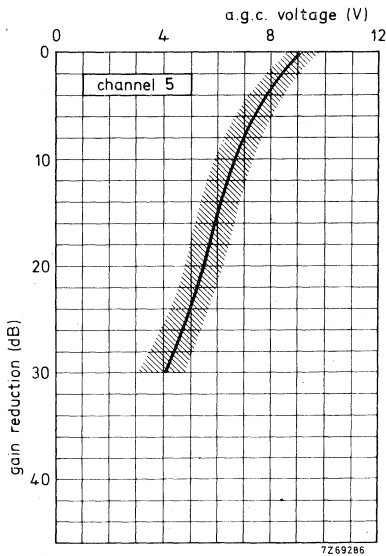

Fig. 7.

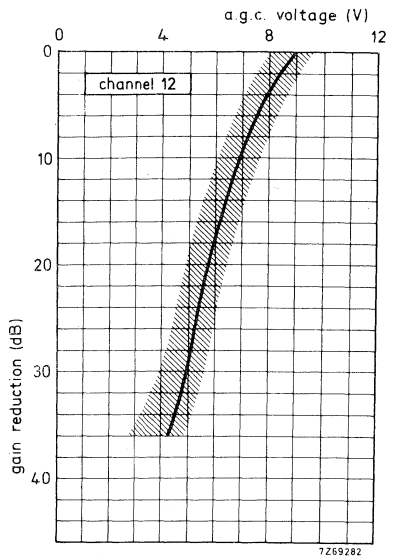

Fig. 8.



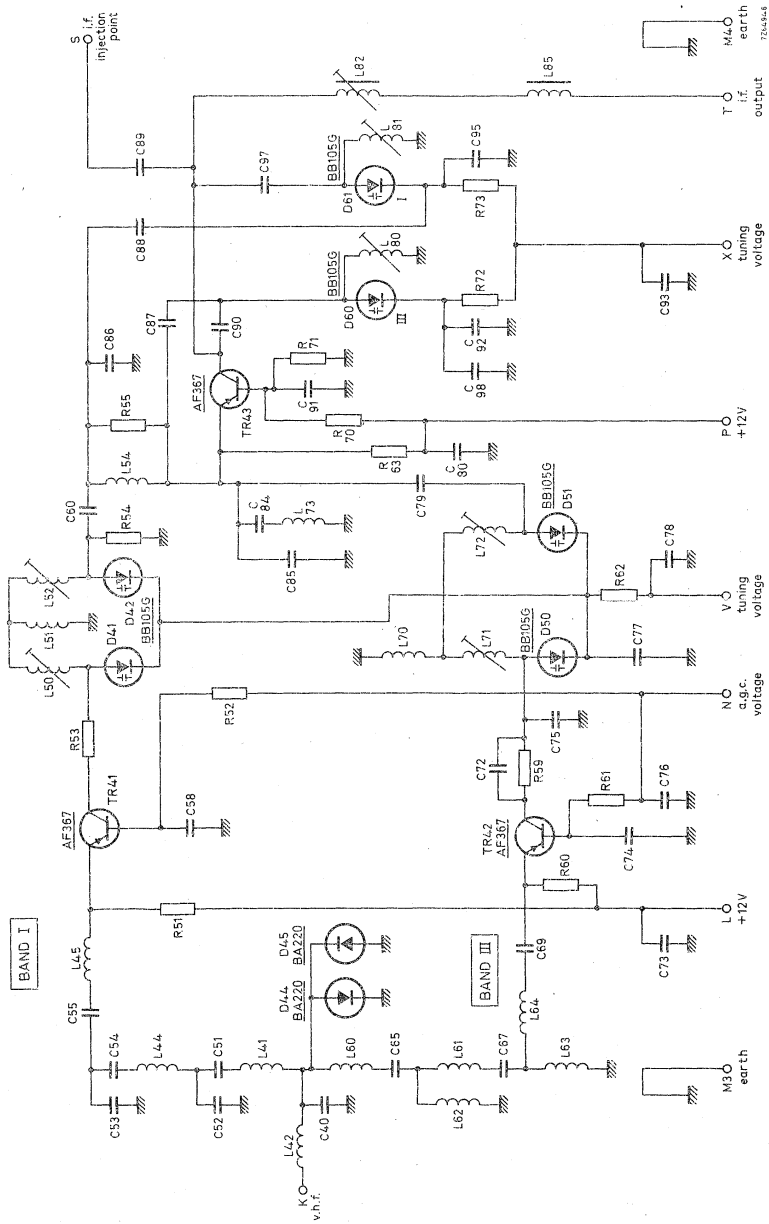

Fig. 9.

COAXIAL AERIAL INPUT ASSEMBLIES

APPLICATION

These coaxial aerial input assemblies have been developed for application in television sets with 75 ohm input impedance, for use in v. h. f. as well as in u. h. f. (40-890 MHz). The connectors meet the demands of both the IEC standards (diameter 9,5 mm) and the French standards (diameter 9,0 mm). They have to be used with plugs complying with the properties mentioned in DIN 45325, IEC 169-2 (diameter 9,5 mm) and SNIR (diameter 9,0 mm). The units meet the safety requirements of IEC 65.

AVAILABLE TYPES

Coaxial aerial input assembly 75 Ω

Attenuation : ≤ 1 dB

Reflection, v. h. f. : $\leq 15\%$

u. h. f. : $\leq 25\%$

Catalogue number : 3122 127 10260

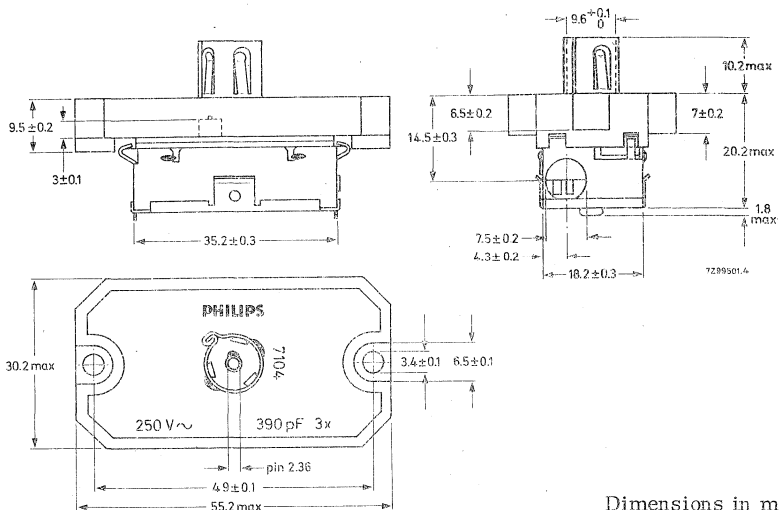
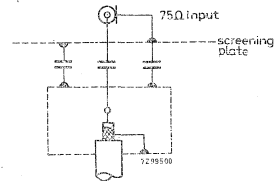

Dimensions in mm

3122 127 10260
 3122 127 10450
 3122 127 14730

COAXIAL AERIAL INPUT ASSEMBLIES

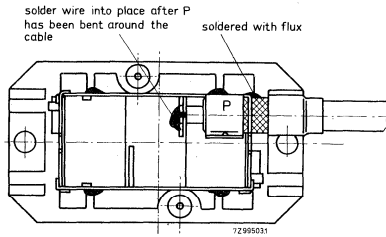

Recommended fixing of the aerial cable
 Soldering conditions: $370 \pm 5 \text{ }^\circ\text{C}$; $3,5 \pm 0,5 \text{ s}$

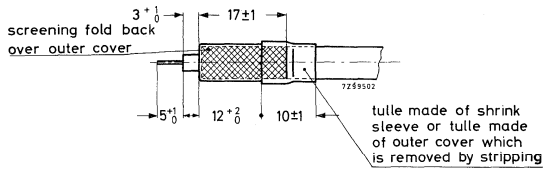

Cable diameter $\geq 5 \text{ mm}$

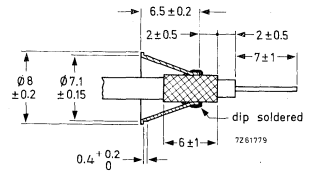

Cable diameter $< 5 \text{ mm}$

Coaxial aerial input assembly 75 Ω, with filter

Reflection, v. h. f. $\leq 25\%$
u. h. f. $\leq 30\%$

Frequency characteristic

v. h. f., 50 to 230 MHz ≤ 1 dB
470 MHz ≥ 13 dB
700 MHz 23 dB (typical value)
u. h. f., 470 to 850 MHz ≤ 1 dB
230 MHz ≥ 15 dB
100 MHz 40 dB (typical value)

Catalogue number 3122 127 10450

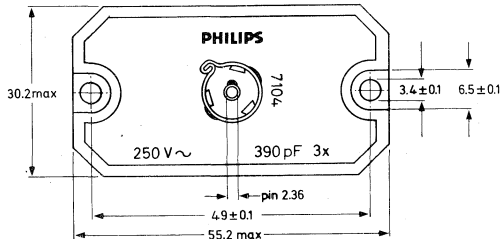
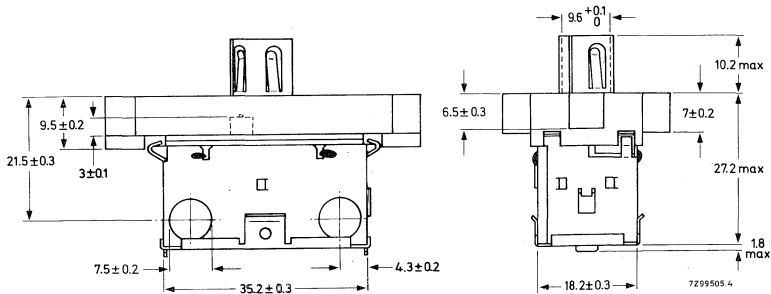
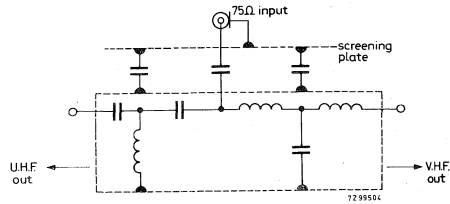

Dimensions in mm

3122 127 10260
 3122 127 10450
 3122 127 14730

COAXIAL AERIAL INPUT ASSEMBLIES

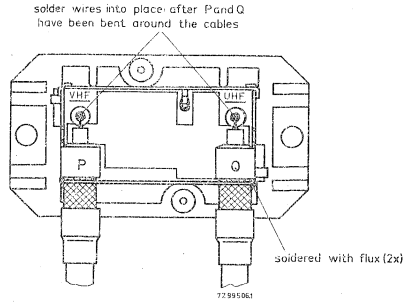

Recommended fixing of the aerial cable
 Soldering conditions: $370 \pm 5 \text{ }^\circ\text{C}$; $3,5 \pm 0,5 \text{ s}$

0000000000
 0000000000
 0000000000
 0000000000
 0000000000
 0000000000

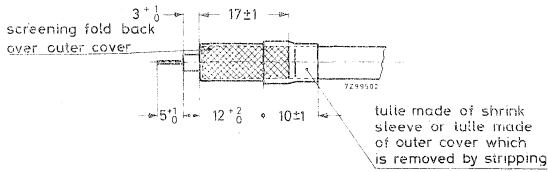

Cable diameter $\geq 5 \text{ mm}$

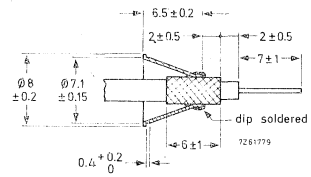

Cable diameter $< 5 \text{ mm}$

Coaxial aerial input assembly 75 Ω, with high-pass filter

Attenuation at 1 MHz : 60 dB (typical value)
 5 MHz : 40 dB (typical value)
 10 MHz : ≥ 25 dB
 50 MHz : ≤ 1 dB
 230 MHz : ≤ 1 dB
 470 MHz : ≤ 1 dB
 850 MHz : $\leq 1,5$ dB

Reflection, v. h. f. I : $\leq 35\%$
 v. h. f. III : $\leq 15\%$
 u. h. f. : $\leq 35\%$

Catalogue number : 3122 127 14730

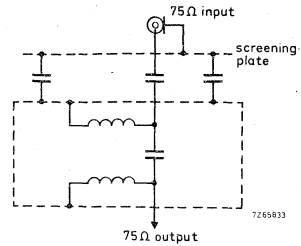

Dimensions in mm

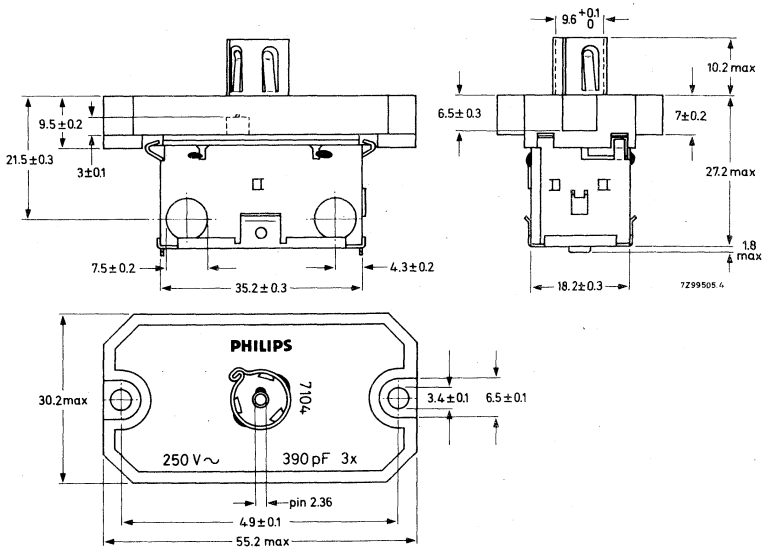

solder wires into place after P has been bent around the cable

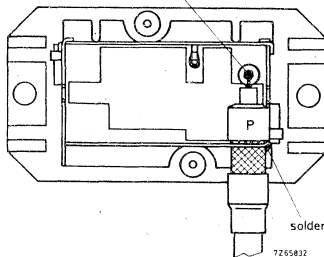

soldered with flux (2x)

Recommended fixing of the aerial cable
 Soldering conditions: 370 ± 5 °C; $3,5 \pm 0,5$ s

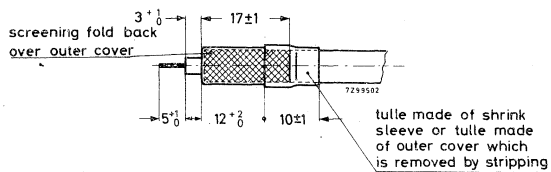

Cable diameter ≥ 5 mm

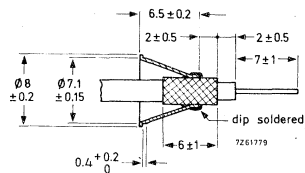

Cable diameter < 5 mm

Components for
black and white television





SURVEY

PREFERRED TYPES

	basic deflection package	associated components	designed with
<u>Consumer applications</u> For 110° picture tubes, neck diameter 28 mm, A44-120 W, 44 cm (17 in) A50-120 W, 50 cm (20 in) A61-120 W, 61 cm (24 in)	deflection unit AT 1040/15 line output transformer AT2048/12	adjustable linearity control unit AT4042/14 line driver transformer AT4043/87	line output transistor BU205
For 31 cm (12 in), 110° picture tube, neck diameter 20 mm, A31-120 W	deflection unit AT 1074 line output transformer AT2140		line output transistor BD407
<u>Professional applications</u> For 17 cm (7 in), 70° monitor tube, neck diameter 28 mm, M17-140 W	deflection unit AT 1071/01 line output transformer AT2102/01	adjustable linearity control unit AT4036	line output transistor BD160
For 90° monitor tubes, neck diameter 28 mm, M24-100 W, 24 cm (9,5 in) M31-130 W, 31 cm (12 in)			
For 38 cm (15 in), 110° monitor tube, neck diameter 28 mm, M38-120 W	deflection unit AT 1040/15 line output transformer AT2048/12	adjustable linearity control unit AT4042/14 line driver transformer AT4043/87	line output transistor BU205

The data sheets of the preferred types are arranged according to their type numbers on the following pages.

NON-PREFERRED TYPES

Abridged data of the following types are given in the tables which can be found after the data sheets of the preferred types.

Deflection units

AT1020/01
AT1038/00
AT1040
AT1040/00
AT1040/03
AT1040/05
AT1072

Line output transformers

AT2023/02
AT2025/01
AT2036/00
AT2036/10
AT2036/37
AT2042/01
AT2072

Linearity control units

AT4034/01
AT4042/02
AT4072

E. H. T. sockets

AT7130
AT7130/01



DEFLECTION UNIT

QUICK REFERENCE DATA	
Picture tube, diagonal	43 cm (17 in), 48 cm (19 in), 51 cm (20 in), 58 cm (23 in) and 61 cm (24 in)
neck diameter	28 mm
Deflection angle	110°
Line deflection current, edge to edge at 18 kV	2, 3 A (p-p)
Inductance of line coils, parallel connected	3, 32 mH
Field deflection current, edge to edge at 18 kV	1, 1 A (p-p)
Resistance of field coils, parallel connected	7, 5 Ω

APPLICATION

This deflection unit has been designed for use with a 110° black and white picture tube in conjunction with:

- line output transformer AT2048/12 or AT2130;
- linearity control unit AT4042/02 or AT4042/14;
- line output transistor BU205.

DESCRIPTION

The saddle-shaped line deflection coils are moulded so that the deflection centre is well within the conical part of the picture tube.
The field deflection coils are wound on a Ferroxcube yoke ring which is flared so that the frame and line deflection centres coincide.

The unit meets the self-extinguishing and non-dripping requirements of IEC 65.

For centring and pin-cushion distortion see under "Correction facilities".

MECHANICAL DATADimensions (in mm) and terminals

Fig. 1. 1) For fitting plastic bonded Fxd magnet strips, catalogue number 3122 137 10160.
 2) For fitting plastic bonded Fxd magnets, catalogue number 3122 104 94120.
 3) For fitting plastic bonded Fxd magnets, catalogue number 3122 104 90360.

The unit is provided with soldering pins for connection. The pin numbering in the figure corresponds to that in the connection diagrams (Figs. 2 and 3).

Weight

300 g approximately

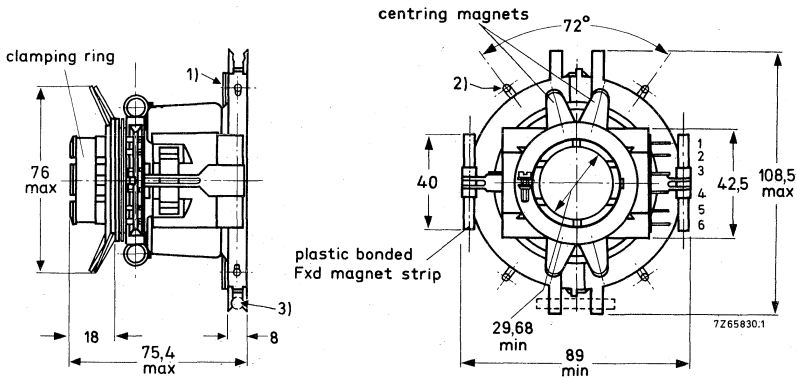
MOUNTING

The unit should be mounted as far forward as possible on the neck of the picture tube, so that it touches the cone.

To orient the raster correctly, the unit may be rotated by hand on the neck of the picture tube, with which it makes a slip fit. A screw-tightened clamping ring permits it to be locked, both axially and radially, in the desired position.

ELECTRICAL DATA

The electrical values apply at an ambient temperature of 25 °C.

Line deflection coils, parallel connected (Fig. 2)
terminals 3 and 4

Inductance	3,32 mH ± 5%
Resistance	6,1 Ω ± 10%

Field deflection coils, parallel connected (Fig. 3)
terminals 1 and 6

Inductance	17 mH ± 10%
Resistance	7,5 Ω ± 8,5%

Maximum peak voltage between terminals of
line and field coils (50 Hz) 2500 V

Maximum operating temperature 105 °C

Fig. 2 Line coils

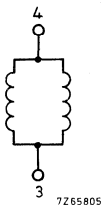
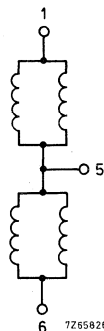

Fig. 3 Field coils



The following characteristics are measured at an e.h.t. of 18 kV on a 61 cm (24 in) reference picture tube.

Sensitivity

Deflection current edge to edge ¹⁾

in line direction	2,3 A p-p ± 7%
in field direction	1,1 A p-p ± 3,5%

¹⁾ Minimum useful screen dimensions: 481 mm x 375 mm.

Geometric distortion (measured without correction magnets)

Barrel distortion in the corners

max. 1 mm

Pin cushion distortion

the edges of the raster fall within the two rectangles shown in Fig. 4.

Trapezium distortion

the edges of the raster fall within the two rectangles shown in Fig. 5.

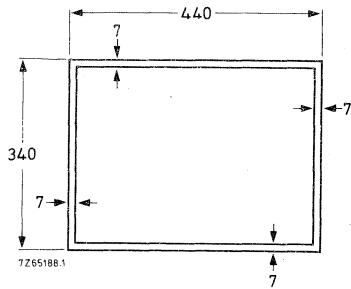

Fig. 4

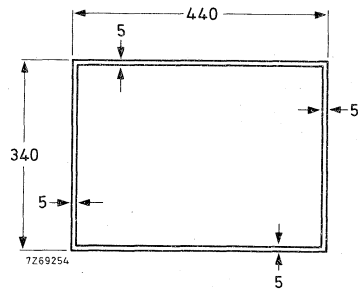

Fig. 5

CORRECTION FACILITIES

For centring

After adjustment of the linearity of the deflection current, the eccentricity of the picture tube and the deflection unit can be corrected by means of two independently movable centring magnets of plastic-bonded ferroxdure. These magnets are magnetised diametrically. By turning the magnets with respect to each other the resulting field strength is varied. The direction of the resulting magnetic field is adjusted by turning the magnets simultaneously.

These centring magnets can not be used for compensating the effects of non-linearity or of phase differences between the synchronisation and time base, as otherwise the correction needed becomes excessive. Even if the correction is within the range of the magnets, curved lines may appear in the centre of the raster.

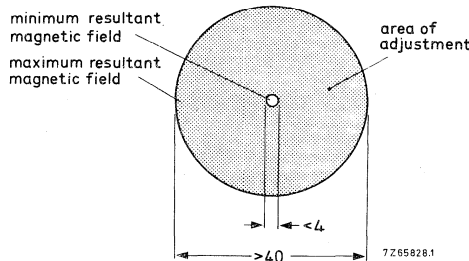

Fig. 6

For pin-cushion distortion

Pin-cushion distortion can be corrected by plastic bonded ferroxdure magnet strips, which have been mounted on the deflection unit brackets ¹⁾. Limited correction of asymmetrical pin-cushion distortion can be achieved by unequal rotation of these magnets.

Notes

To correct the corners of the raster plastic bonded ferroxdure magnets can be fitted to the deflection unit, see Fig. 1.

These magnets can be supplied on request; please quote the 12-digit catalogue number (see Fig. 1) for ordering.



¹⁾ Magnet strips are also available separately under catalogue number 3122 137 10160.

DEFLECTION UNIT for black and white monitors

QUICK REFERENCE DATA	
Monitor tube, diagonal	24 cm (9 in)
neck diameter	28 mm
Deflection angle	90°
Line deflection current, edge to edge at 14 kV	8,6 A (p-p)
Inductance of line coils, parallel connected	93 μ H
Field deflection current, edge to edge at 14 kV	0,425 A (p-p)
Resistance of field coils, series connected	27 Ω

APPLICATION

This deflection unit has been designed for use with a 90° black and white monitor tube type M24-100 W in conjunction with:

line output transformer AT2102/01;
linearity control unit AT4036 and;
line output transistor BD160.

DESCRIPTION

The saddle-shaped line deflection coils are moulded so that the deflection centre is well within the conical part of the picture tube.
The field deflection coils are wound on a Ferroxcube yoke ring which is flared so that the frame and line deflection centres coincide.

For centring and pin-cushion distortion see under "Correction facilities".

MECHANICAL DATA

Dimensions in mm

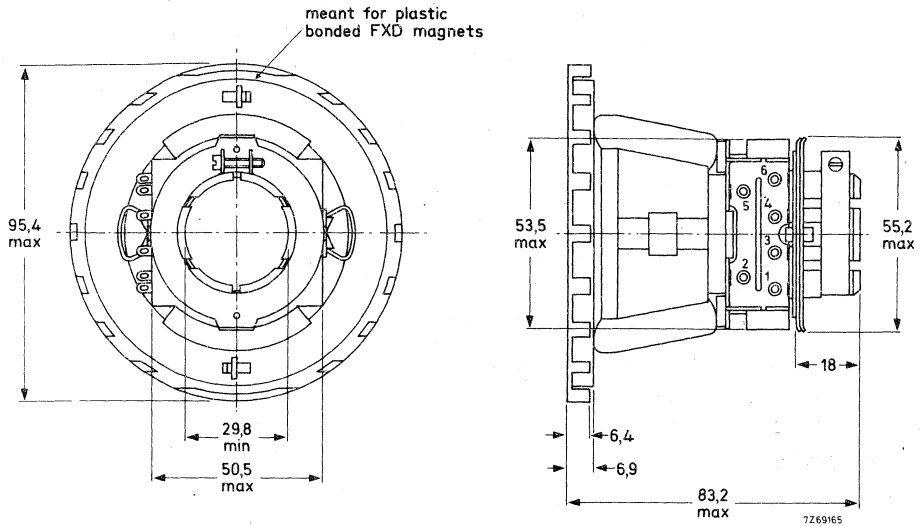

Fig. 1

The unit is provided with soldering pins for connection. The pin numbering in Fig. 1 corresponds to that in the connection diagram (Figs. 3 and 4).

MOUNTING

The unit should be mounted as far forward as possible on the neck of the picture tube, so that it touches the cone. For optimum raster shape, the coil should be mounted as shown in Fig. 2.

To orientate the raster correctly, the unit may be rotated on the neck of the picture tube. A clamping ring locks the unit both axially and radially.

Fig. 2 Front view of picture tube.

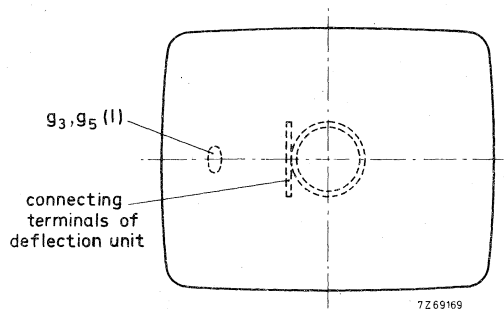

ELECTRICAL DATA

Line deflection coils, parallel connected (Fig. 3)
terminals 3 and 4

Inductance

typ. 93 μ H

Resistance

typ. 0,15 Ω

Field deflection coils, series connected (Fig. 4)
terminals 1 and 5

Inductance

typ. 56 mH

Resistance

typ. 27 Ω

Maximum peak voltage between terminals of
line and field coils (50 Hz)

2000 V

Maximum operating temperature

95 $^{\circ}$ C

Fig. 3 Line coils

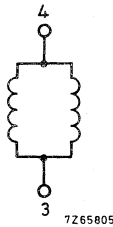
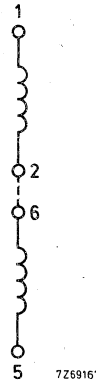

Fig. 4 Field coils



The following characteristics are measured at an e. h. t. of 14 kV on a 24 cm (9 in) reference tube, type M24-100 W.

Sensitivity

Deflection current edge to edge

in line direction

8,6 A (p-p)

in field direction

0,425 A (p-p)

Geometric distortion (measured without correction magnets and centring ring)

Pin-cushion, barrel and trapezium
distortion

The edges of the raster fall within
the two rectangles shown in Fig. 5.

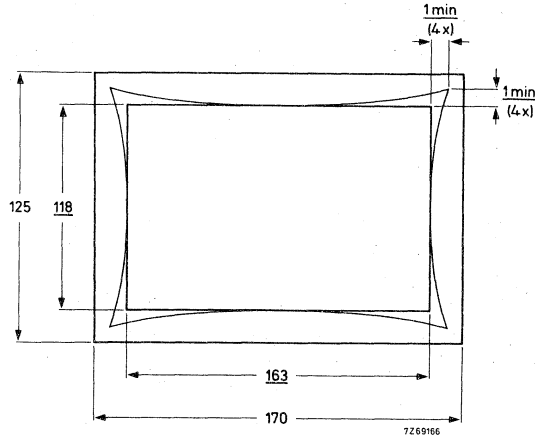

Fig. 5

CORRECTION FACILITIES

For centring

After adjustment of the linearity of the deflection current, the eccentricity of the picture tube and the deflection unit can be corrected by means of two independently movable centring magnets of plastic-bonded Ferroxdure. These magnets are magnetized diametrically. By turning the magnets with respect to each other the resulting field strength is varied. The direction of the resulting magnetic field is adjusted by turning the magnets simultaneously.

These centring magnets can not be used for compensating the effects of non-linearity or of phase differences between the synchronization and time base, as otherwise the correction needed becomes excessive. Even if the correction is within the range of the magnets, curved lines may appear in the centre of the raster.

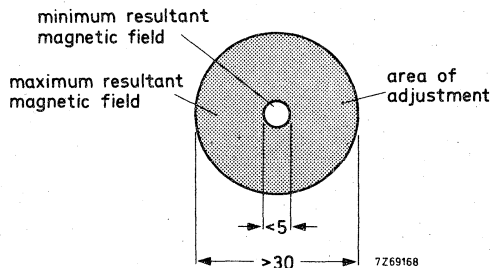

Fig. 6

For pin-cushion distortion

This can be corrected by moving magnets of plastic-bonded Ferroxdure (catalogue number 3122 104 95000) which may be mounted in the rim at the front of the deflection unit.

DEFLECTION UNIT

QUICK REFERENCE DATA	
Picture tube, diagonal neck diameter	31 cm (12 in), 34 cm (14 in) max. 20,9 mm
Deflection angle	110°
Line deflection current for full scan, at 10 kV	5,1 A (p-p) ¹⁾
Inductance of line coils, parallel connected	255 μH
Field deflection current for full scan, at 10 kV	1,1 A (p-p)
Resistance of field coils, parallel connected	2,7 Ω

APPLICATION

This deflection unit has been designed for use with a 31 cm (12 in) or 34 cm (14 in) 110° black and white picture tube in conjunction with:

- line output transformer AT2140;
- line output transistor BU407.

DESCRIPTION

The saddle shaped line deflection coils are moulded so that the deflection centre is well within the conical part of the picture tube.

The field deflection coils are wound on a Ferroxcube yoke ring which is flared so that the frame and line deflection centres coincide.

The unit meets the self-extinguishing and non-dripping requirements of IEC 65.

For centring and pin-cushion distortion see under "Correction facilities".

¹⁾ Measured without S-correction, with d.c. current.

MECHANICAL DATA

Dimensions in mm

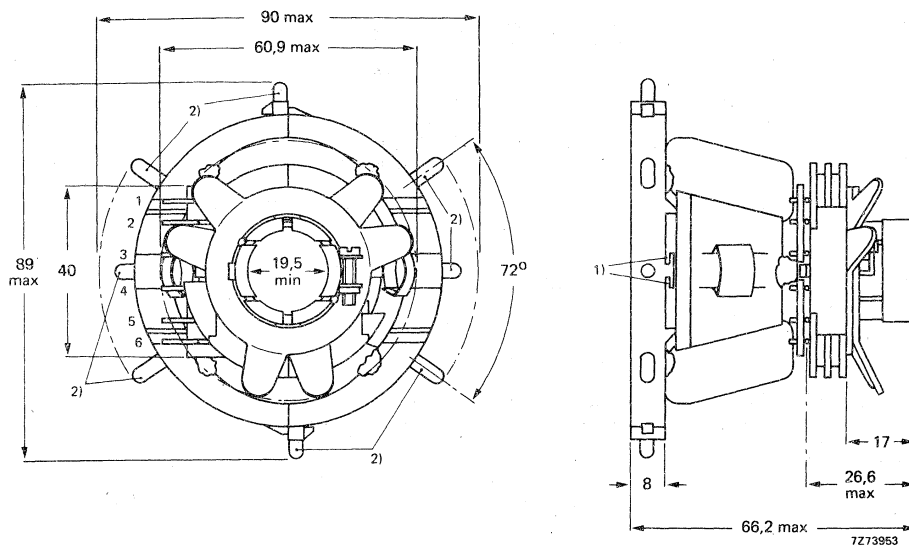

Fig. 1. 1) For fitting plastic-bonded FXD magnet strips,
catalogue number 3122 137 10160.
2) For fitting plastic-bonded FXD magnets,
catalogue number 3122 104 94120.

The unit is provided with soldering pins for connection. The pin numbering in Fig. 1 corresponds to that in the connection diagrams (Fig. 2).

MOUNTING

The unit should be mounted as far forward as possible on the neck of the picture tube, so that it touches the cone.

To orient the raster correctly, the unit may be rotated by hand on the neck of the picture tube, with which it makes a slip fit. A screw-tightened clamping ring permits it to be locked, both axially and radially, in the desired position.

ELECTRICAL DATA

The electrical values apply at an ambient temperature of 25 °C.

Line deflection coils, parallel connected (Fig. 2a)

terminals 3 and 4

Inductance	255 $\mu\text{H} \pm 5\%$
Resistance	0,56 Ω
L/R	455 $\mu\text{H}/\Omega \pm 8\%$

Field deflection coils, parallel connected (Fig. 2b)

terminals 1 and 6

Inductance	7,9 mH $\pm 8\%$
Resistance	2,7 Ω
L/R	2,87 mH/ $\Omega \pm 10\%$

Maximum d.c. voltage between terminals of line and field coils

500 V

Maximum operating temperature

95 °C

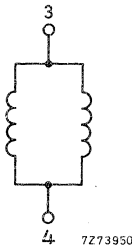

Fig. 2a. Line coils

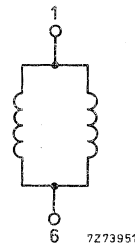

Fig. 2b. Field coils

The following characteristics are measured at an e. h. t. of 10 kV on a 31 cm (12 in) reference picture tube.

Sensitivity

Deflection current

in line direction, for 230 mm scan	4,6 A(p-p)
	for full scan 5,1 A(p-p)
in field direction, for 175 mm scan	1,0 A(p-p)
	for full scan 1,1 A(p-p)

Geometric distortion (measured without correction magnets)

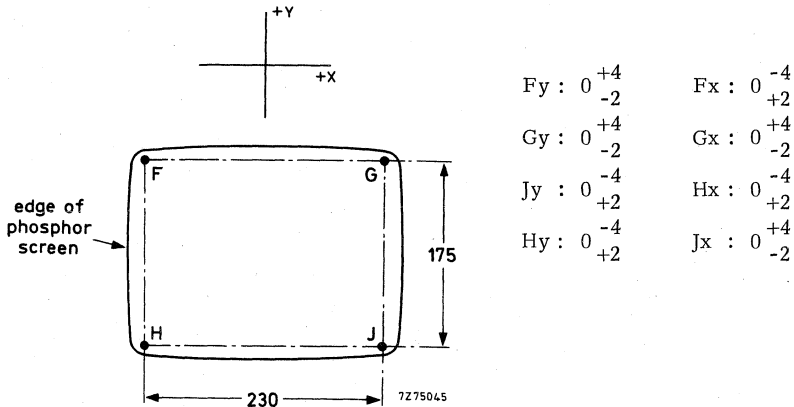

Fig. 3

CORRECTION FACILITIES

For centring

After adjustment of the linearity of the deflection current, the eccentricity of the picture tube and the deflection unit can be corrected by means of two independently movable centring magnets of plastic-bonded Ferroxdure. These magnets are magnetized diametrically. By turning the magnets with respect to each other the resulting field strength is varied. The direction of the resulting magnetic field is adjusted by turning the magnets simultaneously.

These centring magnets can not be used for compensating the effects of non-linearity or of phase differences between the synchronization and time base, as otherwise the correction needed becomes excessive. Even if the correction is within the range of the magnets, curved lines may appear in the centre of the raster.

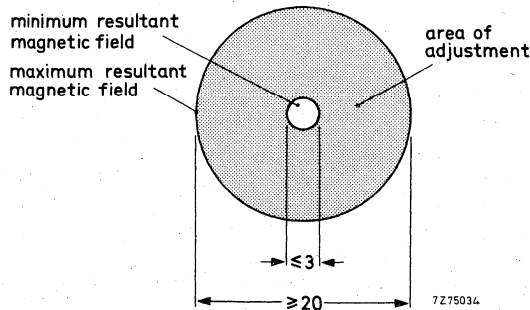

Fig. 4

For geometric distortion

The unit has provisions for mounting brackets for magnet strips ¹⁾ to correct pin-cushion distortion and for magnets ²⁾ to correct the raster corners, see Fig. 1.



1) Plastic-bonded Ferroxdure magnet strips are available on request (catalogue number 3122 137 10160).

2) Plastic-bonded Ferroxdure magnets are available on request (catalogue number 3122 104 94120).

LINE OUTPUT TRANSFORMER

QUICK REFERENCE DATA			
I_{eht}	35	435	μA
E. H. T.	17,7	16,2	kV
$R_i(eht)$		4,0	$M\Omega$
Supply voltage (V_B)	188	186	V
current (I_B)	212	250	mA
I p-p deflection	2,20	2,15	A
Auxiliary voltages	-300 V p, +60 V p, -60 V p and 7,7 V r. m. s.		

APPLICATION

This transformer has been designed to provide the required scanning amplitude for 43 cm (17 in) to 61 cm (24 in) 110° black and white picture tubes with a neck diameter of 28 mm in transistor equipped television receivers presenting 625 lines at 50 frames per second (CCIR) or 525 lines at 60 frames per second (USA).

It is intended for use in conjunction with:

- deflection unit AT1040/15
- adjustable linearity control unit AT4042/02
- line output transistor BU205
- E.H.T. rectifier device selenium stack.

DESCRIPTION

The magnetic circuit of the transformer comprises two Ferroxcube U-cores, clamped together with a bracket. The primary windings, the auxiliary windings and the E.H.T. windings are situated on one leg of the core. The E.H.T. windings are encapsulated in flame retardant polyester. The whole transformer meets the self-extinguishing and non-dripping properties of the American Underwriters' Laboratories rating mentioned in UL94SE-1.

The transformer is provided with four mounting pins. External circuit connection is made to connecting pins, positioned as indicated in Fig. 1 enabling the unit to be soldered directly into a printed-wiring board.

MECHANICAL DATA

Dimensions (in mm) and terminals

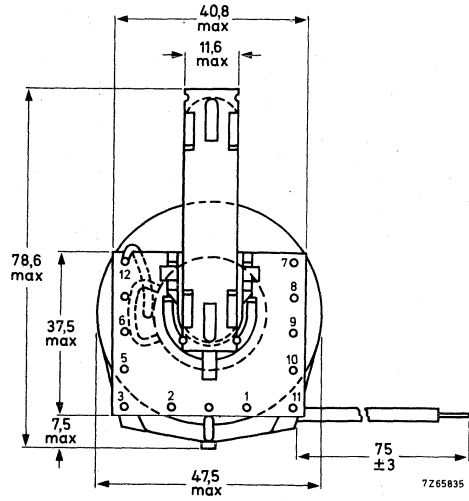
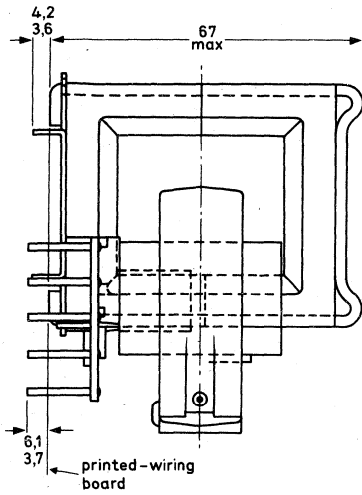

Fig. 1

Weight

155 g approximately

MOUNTING

The transformer may be mounted on a printed-wiring board. The fit of the connecting pins in a printed-wiring grid with a pitch of 2,54 mm (0,1 in) is illustrated in Fig. 2. The core of the transformer must be earthed.

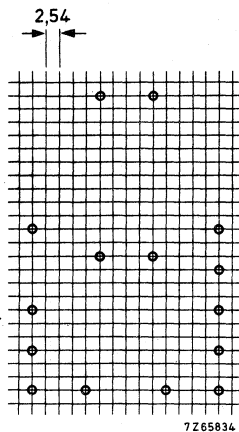

Fig. 2 Hole pattern for mounting on a printed-wiring board (solder side)
Grid holes $1,3 \pm 0,1$ mm

Temperature

The operating temperature of the core and the coils should not exceed 105°C , under worst conditions, i. e. taking into account:

- overvoltage on the windings
- low atmospheric pressure (at high altitudes) implying bad cooling by convection
- high room temperature (up to 45°C).

To satisfy this requirement it may be desired to provide ample cool air circulation around the transformer.

Distances

The following minimum distances between the transformer and neighbouring conductive flat surfaces (in proportion to their sharpness protruding parts must have a greater distance) must be maintained:

- a. From the e. h. t. winding, radially 25 mm
axially 15 mm
- b. From the e. h. t. lead 25 mm

The transformer, and the leads and components carrying high voltage pulses should be kept free from metal particles, solder drops etc.

ELECTRICAL DATA (see circuit diagram)

E.H.T. supply	I_{eht}	μA	35	435	
	E.H.T.	kV	17,7	16,2	
	$R_{\text{i(eht)}}$	M Ω		4,0	
Power supply	V_{B}	} 1)	V	200	
	$V_{\text{B}'}$		V	188	186
	I_{av}		mA	212	250
Output transistor	V_{CEM}	V	1080	1100	
	I_{CM}	A	1,4	1,45	
	$I_{\text{p-p}}$	A	2,20	2,15	
Deflection	Flyback ratio (average)	%		18	
	Overscan variation	%	6	10	
Auxiliary windings, connecting pin 5 connecting pin 7 connecting pin 9 connecting pins 10, 11		V p	-300		
		V p	+60		
		V p	-60		
		V r. m. s.	7,7		

¹⁾ Measured at pin 1

Circuit diagram

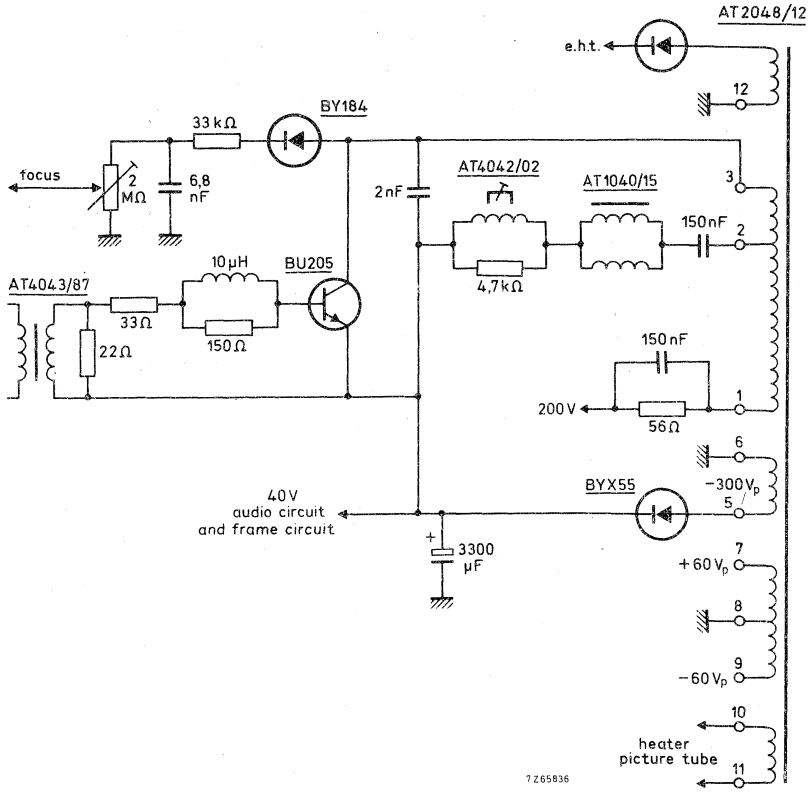

Fig. 3

LINE OUTPUT TRANSFORMER for black and white monitors

QUICK REFERENCE DATA			
I _{eht}	0,03	0,23	mA
E. H. T.	14,5	13,2	kV
R _i (eht)		6	MΩ
I _{p-p} deflection	8		A
Supply voltage (V _B)	12	12	V
current (I _B)	830	1100	mA
Voltages of auxiliary windings	-102 V(p), +820 V(p)		

APPLICATION

This transformer has been designed to provide the required scanning amplitude for 24 cm (9 inch) 90° monitor tubes with a neck diameter of 28 mm in transistor equipped monitors presenting 625 lines at 50 frames per second (CCIR), or 525 lines at 60 frames per second (USA).

It is intended for use in conjunction with:

- deflection unit AT 1071/01;
- linearity control unit AT4036;
- line output transistor BD160;
- booster (efficiency) diode BYX55, BYX 71;
- e. h. t. rectifier device TV 18KT.

See also circuit diagram of Fig. 3.

DESCRIPTION

The magnetic circuit of the transformer comprises Ferroxcube U and I-cores clamped together with brackets.

The primary windings and the auxiliary windings are situated on one leg of the core, the e. h. t. winding and the coupling winding are situated on the other leg. The e. h. t. winding is encapsulated in flame retardent polyester. The whole transformer meets the self-extinguishing requirements of IEC publication 65, para. 14.4 and UL492, para. 280-SE 1. The transformer is provided with four mounting pins.

External circuit connection is made to connecting pins, positioned as indicated in Fig. 1 enabling the unit to be soldered directly into a printed-wiring board.

MECHANICAL DATA

Dimensions in mm

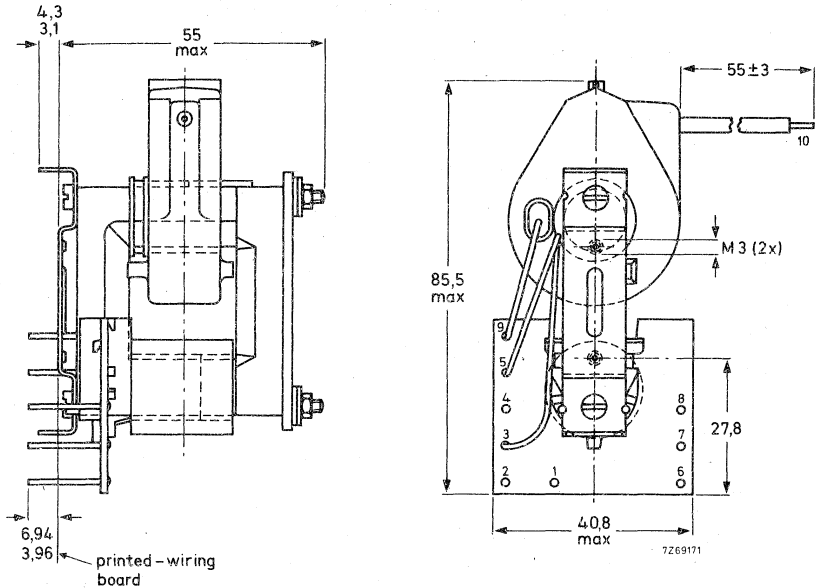

Fig. 1

MOUNTING

For mounting on a printed-wiring board the fit of the connecting and mounting pins in a printed-wiring grid with a pitch of 2,54 mm (0,1 in) is illustrated in Fig. 2. The transformer core must be earthed.

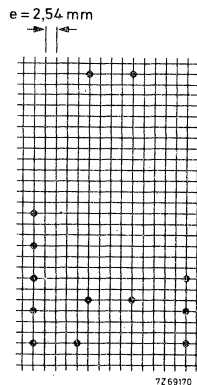

Fig. 2 Hole pattern for mounting on a printed-wiring board (solder side).
Grid holes 1,3 ± 0,1 mm.

Temperature

The operating temperature of the core and the coils should not exceed 95 °C under worst conditions, i.e. taking into account:

- over-voltage on the windings;
- low atmospheric pressure (at high altitudes) implying bad cooling by convection;
- high room temperature (up to 45 °C).

To satisfy these requirements it may be desirable to provide ample cool air circulation around the transformer.

Distances

The following minimum distances between the transformer and neighbouring conductive flat surfaces must be maintained (it should be noticed that edges of conductive parts must have a greater distance):

- from the e.h.t. winding, radially 20 mm,
axially 12 mm;
- from the e.h.t. cap and lead 20 mm;
- from the primary coil 10 mm;
- between the upper edge of the rectifier socket and the primary coil 10 mm.

The transformer, and the leads and components carrying high voltage pulses should be kept free from metal particles, solder drops, etc.

ELECTRICAL DATA

Measured in the circuit shown in Fig. 3 (auxiliary windings unloaded).

E.H.T. supply	I_{eht}	mA	0,03	0,23
	e.h.t.	kV	14,5	13,2
	$R_{i(eht)}$	M Ω	6	
Power supply	V_B	V	12	12
	V_B'	V	24	23,7
Output transistor	$I_{average}$	mA	830	1100
	V_{CEM}	V	180	
Deflection	I_{p-p}	A	8	
	Overscan variation	%		3
Auxiliary windings, connecting pin 6		V_p	+820	
connecting pin 8		V_p	-102	

Application circuit

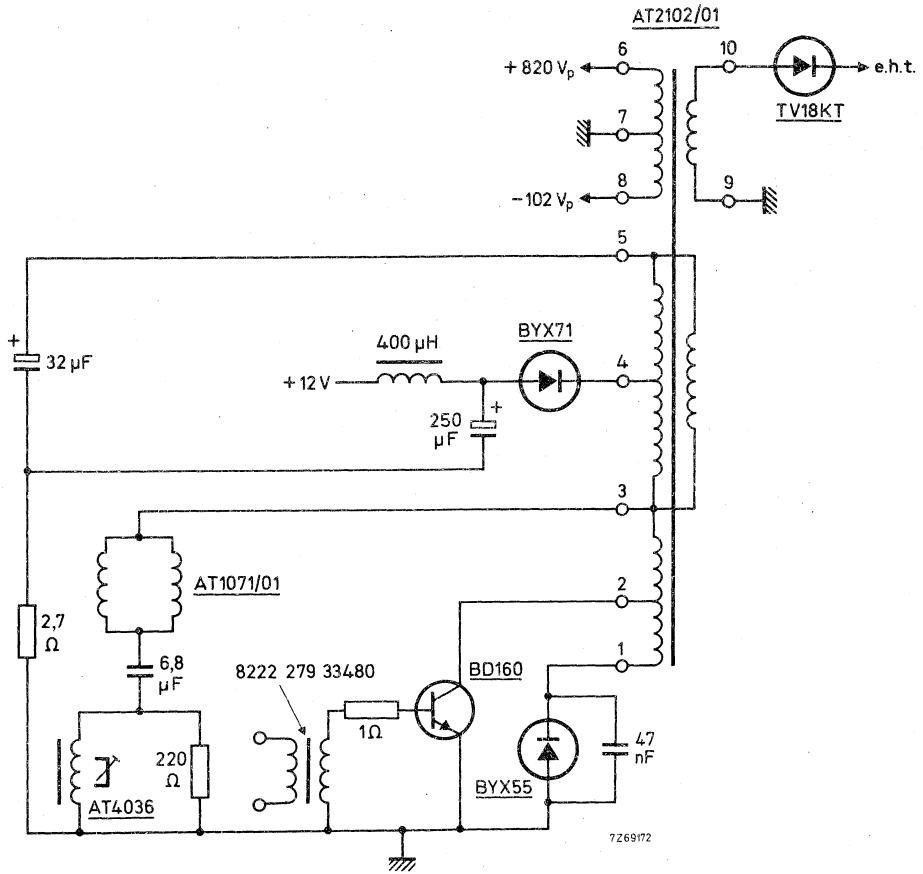

Fig. 3

LINE OUTPUT TRANSFORMER with integral e.h.t. rectifier diode

QUICK REFERENCE DATA	
I_{eht}	25 μA
E.H.T.	10,2 kV
$R_{\text{i(eht)}}$	$\leq 5,5 \text{ M}\Omega$
Supply voltage (V_{B})	10,4 V
current (I_{B})	0,86 A
I(p-p) deflection	4,9 A
Auxiliary voltages 11,2 V (a.c.), +350 V(d.c.), +100 V(d.c.), +13 V(d.c.), +25 V(d.c.)	

APPLICATION

This transformer has been designed to provide the required scanning amplitude for 31 cm (12 in) and 34 cm (14 in) 110° black and white picture tubes with a neck diameter of 20 mm in transistor equipped television receivers presenting 625 lines at 50 frames per second (CCIR) or 525 lines at 60 frames per second (USA).

It is intended for use in conjunction with:

- deflection unit AT1074;
- line output transistor BU407.

DESCRIPTION

The magnetic circuit of the transformer comprises two Ferroxcube U-cores, clamped together with a bracket. The primary winding, the auxiliary windings and the e.h.t. winding are situated on one leg of the core. An e.h.t. rectifier diode is incorporated in the transformer. The e.h.t. winding is encapsulated in flame retardant polyester. The whole transformer meets the self-extinguishing and non-dripping properties of the American Underwriters' Laboratories rating mentioned in UL94SE-1.

The transformer is provided with four mounting pins. External circuit connection is made to connecting pins, positioned as indicated in Fig. 1 enabling the unit to be soldered directly into a printed-wiring board.

MECHANICAL DATA

Dimensions in mm

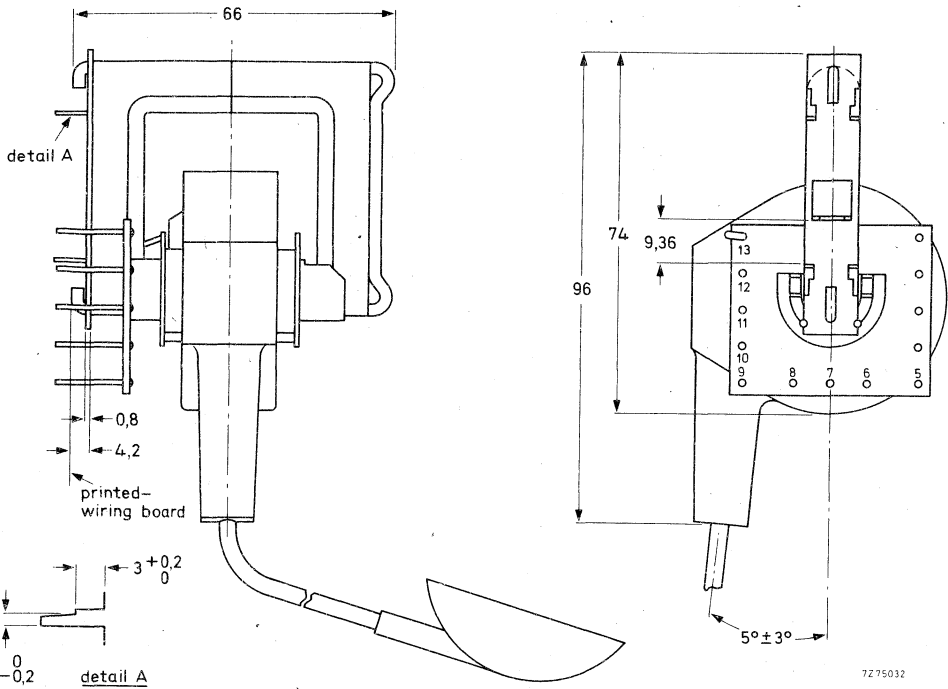

Fig. 1

MOUNTING

The transformer may be mounted on a printed-wiring board. The fit of the connecting pins in a printed-wiring grid with a pitch of 2,54 mm (0,1 in) is illustrated in Fig. 2. The core of the transformer must be earthed.

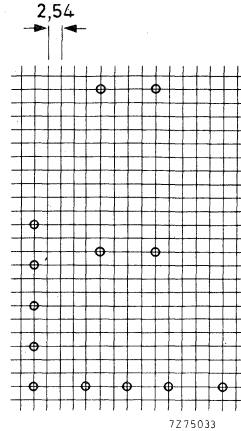

Fig. 2. Hole pattern for mounting on a printed-wiring board (solder side).
Grid holes $1,3 \pm 0,1$ mm.

Temperature

The operating temperature of the core and the coils should not exceed 90 °C, under worst conditions, i.e. taking into account:

- over-voltage on the windings;
- low atmospheric pressure (at high altitudes) implying bad cooling by convection;
- high room temperature (up to 45 °C).

To satisfy these requirements it may be desirable to provide ample cool air circulation around the transformer.

Distances

The following minimum distances between the transformer and neighbouring conductive flat surfaces must be maintained (in proportion to their sharpness protruding parts must have a greater distance):

- a. From the e.h.t. winding, radially 15 mm
axially 10 mm
- b. From the e.h.t. lead 15 mm

The transformer, and the leads and components carrying high-voltage pulses should be kept free from metal particles, solder drops etc.

ELECTRICAL DATA (see circuit diagram)

E. H. T. supply	I_{eht}	μA	25	250
	E. H. T.	kV	10,2	9,0
	$R_{i(eht)}$	M Ω	$\leq 5,5$	
Power supply	V_B	V	10,4	
	I_B	mA	860	
Output transistor	V_{CEM}	V (p-p)	160	
	I_{CM}	A (p-p)	3,4	
	$I_{(p-p)}$	A	4,9	
Deflection	Flyback ratio (average)	%	19	
	Overscan variation	%	6	10
Auxiliary windings, connecting pin 5 connecting pin 9 connecting pin 10 connecting pin 11 connecting pin 12		1)	V	11,2 (booster voltage)
			V (d. c.)	+350
			V (d. c.)	+100
			V (d. c.)	+13
			V (d. c.)	+25

1) After rectification.

Circuit diagram

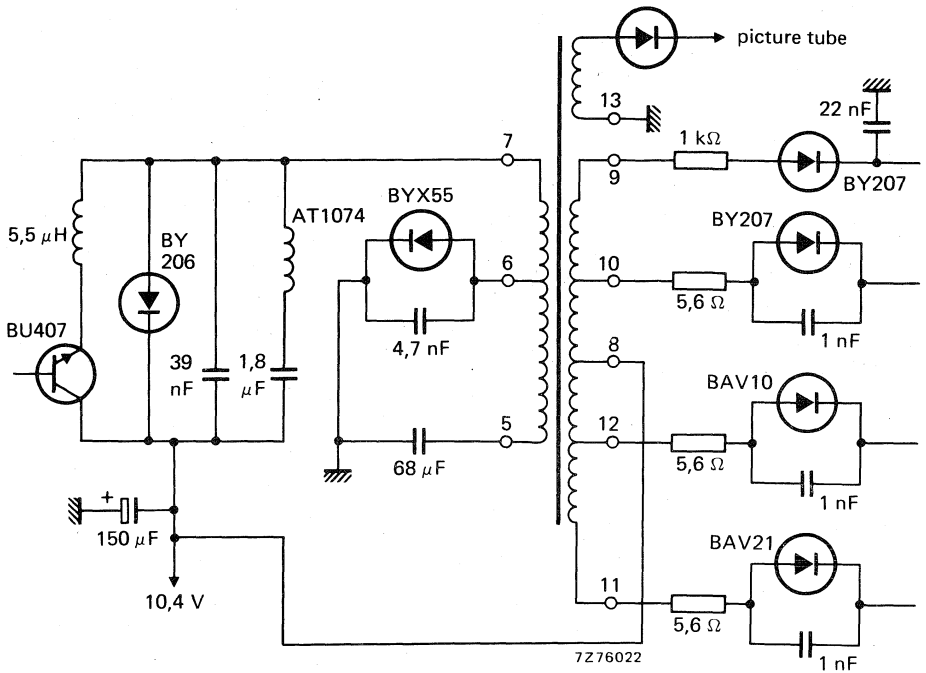
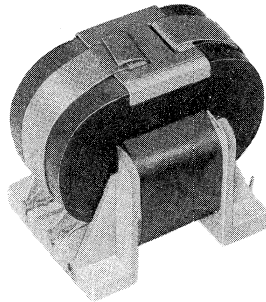

Fig. 3

FRAME-OUTPUT TRANSFORMER



RZ 24284-11

For tube-equipped and transistorised television receivers

APPLICATION

This frame-output transformer is intended for use with 19 and 23 inch 110° (114°) picture tubes, in conjunction with the deflection unit AT1040.

CONSTRUCTION

The magnetic circuit of the transformer comprises two C-cores. The transformer has three separate windings; the tertiary winding can be used for voltage feedback. The transformer has been provided with four holes for mounting on either a printed-wiring board or a metal chassis.

External circuit connection is made to connecting pins, positioned as indicated in Fig.1.



Dimensions in mm

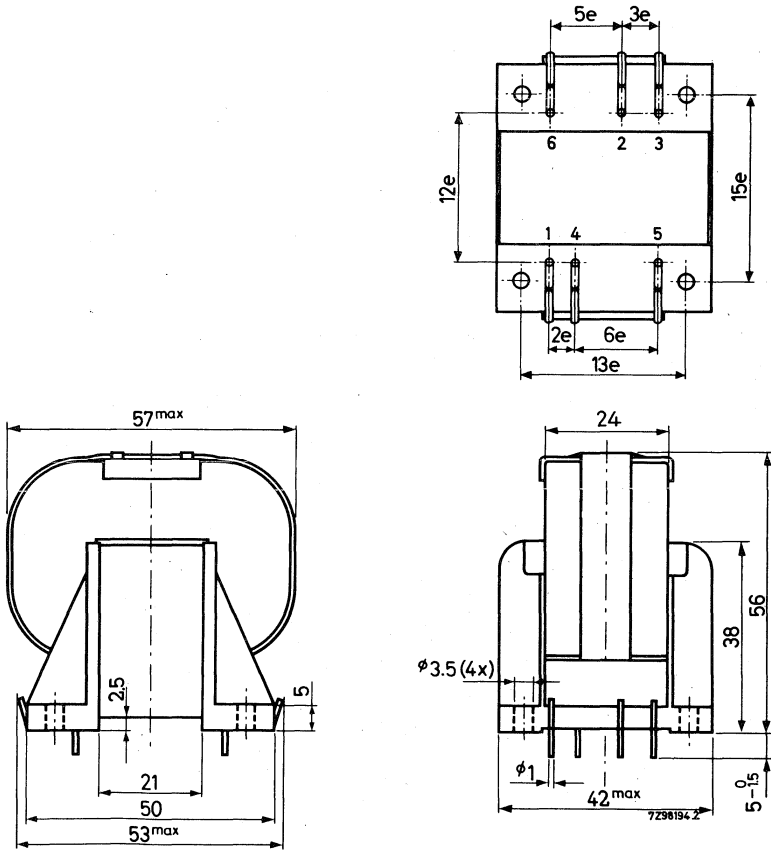

Fig.1. $e = 2.52$ mm, suitable for mounting on a grid with 2.54 mm ($0.1''$) or 2.50 mm pitch.

ELECTRICAL DATA

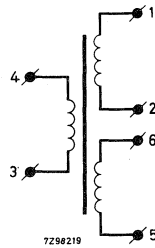

Fig.2

Primary winding	
Connecting terminals	1 and 2
Inductance	
at a primary d.c. current of 55 mA	7.5 H \pm 10%
at a primary d.c. current of 70 mA	6 H \pm 10%
Resistance	230 Ω \pm 12%
Secondary winding	
Connecting terminals	3 and 4
Resistance	9.7 Ω \pm 12%
Tertiary winding	
Connecting terminals	5 and 6
Resistance	165 Ω \pm 12%
Transformation ratio	$\frac{N_{\text{prim}}}{N_{\text{sec}}}$ 5.6
	$\frac{N_{\text{prim}}}{N_{\text{tert}}}$ 3.9
Maximum primary d.c. current	75 mA
Maximum primary peak voltage	1500 V
Maximum ambient temperature	70 °C

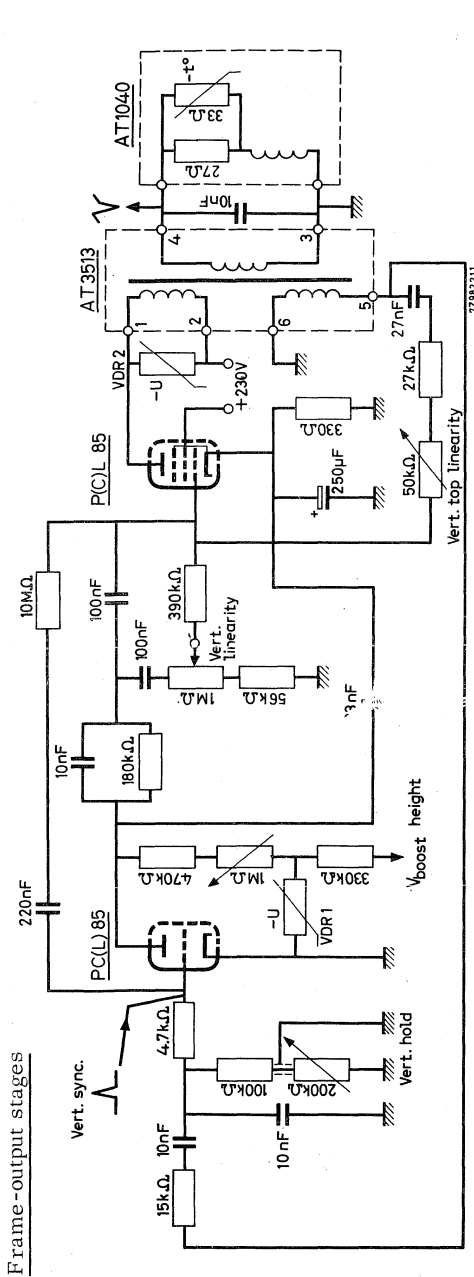

Fig. 3

Pentode data:

- Supply voltage 230 V
- Anode peak voltage 1) 840 V
- Anode voltage at end of scan 1) 85 V
- Anode peak current 160 mA
- Anode d.c. current 57 mA
- Anode standing current 12 mA
- Anode dissipation 7.2 W
- Screen-grid dissipation 1.2 W

Voltage dependent resistors:

$VDR_1 = VDR_2$

1 W disc, 330 V; 2322 553 03541

1) With respect to chassis.

ADJUSTABLE LINEARITY CONTROL UNIT

RZ 19806-3

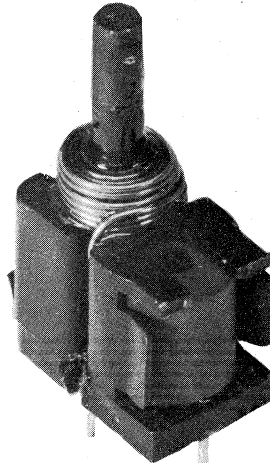

For transistor-equipped television receivers

APPLICATION

This linearity control unit is designed to be used in television receivers, in combination with the 11 inch 90° picture tube A28-14W and the 12 inch 90° picture tube A31-20W. The unit is intended for use in transistor-equipped sets, in conjunction with the deflection unit AT1020/01 and the line-output transformer AT2042/01.

CONSTRUCTION

The unit consists of a coil wound on a ferroxcube rod and two ferroxdure magnets. One of these magnets has the shape of a half ring and is placed around the ferroxcube rod under the coil. The other magnet is cylindrical; it is placed parallel to and clamped against the ferroxcube rod opposite the first one. This magnet is provided with a square hole to facilitate turning of it to adjust the biasing field and so the linearity of the line deflection.

Dimensions in mm

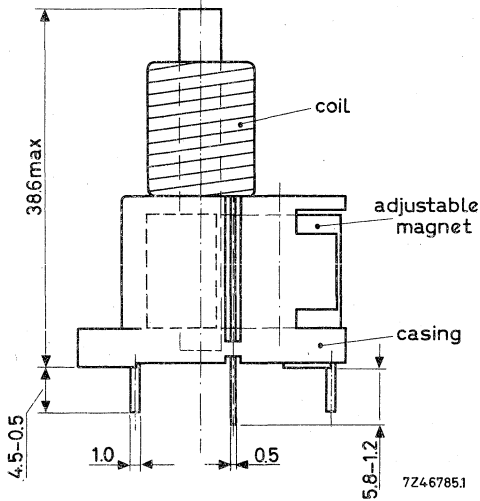
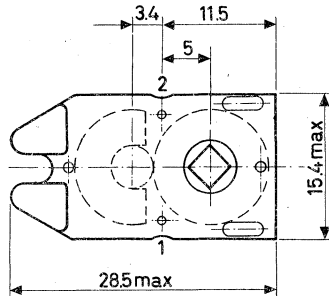

Fig. 1

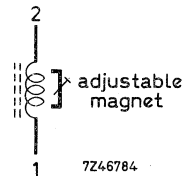

Fig. 2. Circuit diagram

ELECTRICAL DATA

When a saw-tooth current (without S-correction) of $6 A_{p-p}$, frequency 15,625 Hz, flyback ratio 18%, flows through the linearity control unit (one connection point to earth), the correction voltage is adjustable between 1.05 V and 1.95 V.

MOUNTING

The unit can be mounted either on printed-wiring boards by means of its two connection pins and two mounting pins (see Fig. 3), or on conventional panels by bending of the two mounting pins and/or by means of a screw through an aperture in the casing (see Fig. 4). To prevent distortion of the magnetic field no iron part should approach the magnetic parts anywhere nearer than 3 mm. The coil should be shunted with a 1 W carbon resistor to damp ringing phenomena.

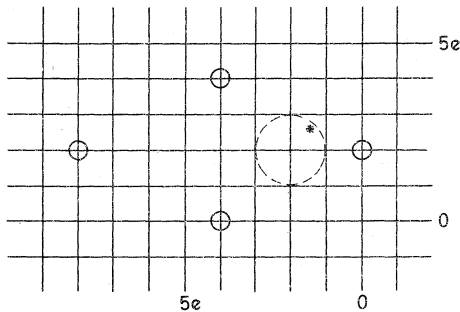

724-6786

Fig. 3
Hole pattern for
mounting on a print-
ed-wiring board
($e = 0.1$ inch or 2.50
mm)

Fig. 4. Hole pattern for mounting on
a chassis.

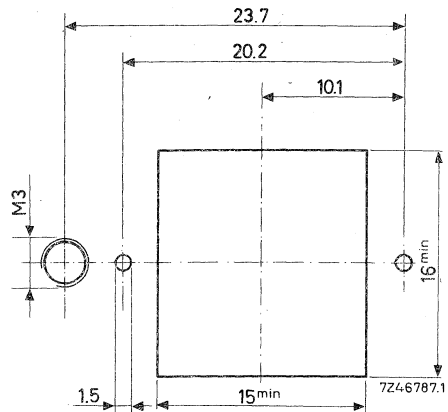

*) Hole only necessary for bottom adjustment.

LINEARITY CONTROL UNIT

APPLICATION

This non-adjustable linearity control unit is designed for use in black and white television sets equipped with 110° deflection angle picture tube.

It is intended for use in conjunction with:

- deflection unit AT 1040/15;
- line output transformer AT 2048/12.

DESCRIPTION

The unit consists of a coil wound on a Ferroxcube rod, and a Ferroxdure magnet, which is placed around the rod next to the coil.

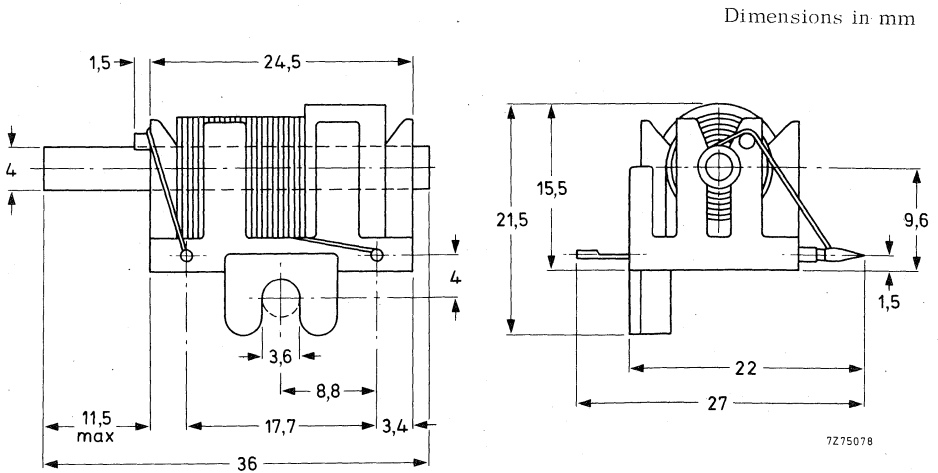

Fig. 1

ELECTRICAL DATA

When a saw-tooth current (without S-correction) of 2,2 A(p-p), frequency 15 625 Hz, flyback ratio 18%, flows through the linearity control unit, the correction voltage is 17 V.

MOUNTING

The unit can be mounted on printed-wiring boards by means of its two connection pins and two mounting pins (see Fig. 1). To prevent distortion of the magnetic field no iron part should approach the magnetic parts anywhere nearer than 3 mm.

LINE DRIVER TRANSFORMER

APPLICATION

This transformer has been designed for black and white, and colour television sets equipped with transistors.

In black and white television sets it can be used in the single-transistor (BU205) line output circuit in conjunction with the line output transformer AT2048/12.

For further information see section "Components for colour television".



DEFLECTION UNITS

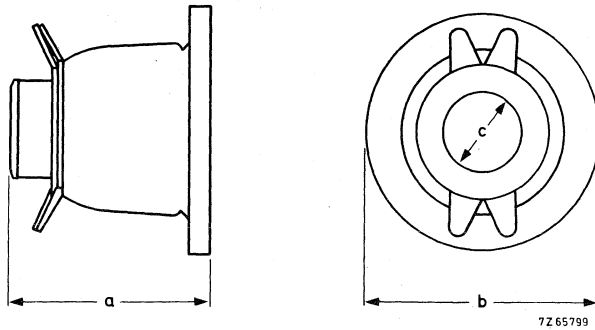

type	dimensions (mm)		
	$a_{\max}^1)$	$b_{\max}^1)$	c_{\min}
AT1020/01	83	103	20,9 ²⁾
AT1038/00	78	125	29,68
AT1040	75,4	108,5	29,68
AT1040/00	72,3	95	29,68
AT1040/03	72,3	95	29,68
AT1040/05	72,3	95	29,68
AT1072	67	90	20,9 ²⁾

3)

1) Protruding parts, e.g. magnet clamps, included.

2) For picture tubes with a neck diameter of 20 mm.

3) For picture tubes with a neck diameter of 28 mm.



NON-PREFERRED TYPES

DEFLECTION UNITS

Type number	AT1020/01	AT1038/00	AT1040
Catalogue number	3122 108 55440	3122 137 13310	3122 137 14600
Inductance			
line deflection coils	81 μ H	2,9 mH	2,09 mH
field deflection coils	42 mH	82 mH	68,1 mH
Resistance			
line deflection coils	0,15 Ω	4,5 Ω	3,55 Ω
field deflection coils	30 Ω	38 Ω	29 Ω
NTC thermistor, without parallel resistor	-	10 Ω	33 Ω
E. H. T.	11 kV	18 kV	18 kV
Sensitivity			
in horizontal direction	7,2 A (p-p)	2,29 A (p-p)	2,9 A (p-p)
in vertical direction	0,34 A (p-p)	0,44 A (p-p)	0,54 A (p-p)
To be used with picture tube	28 cm (11 in), 90 ⁰	58 cm (23 in), 110 ⁰	43 cm (17 in), 110 ⁰ 48 cm (19 in), 110 ⁰ 51 cm (20 in), 110 ⁰ 58 cm (23 in), 110 ⁰ 61 cm (24 in), 110 ⁰
line-output transformer	AT2042/01	AT2025/01	AT2036/37
adjustable linearity control unit	AT4036	AT4034/01	AT4042/02
Replaced by	-	-	-

DEFLECTION UNITS

NON-PREFERRED
TYPES

AT1040/00 3122 108 69990	AT1040/03 3122 238 50880	AT1040/05 3122 137 10690	AT1072 3122 107 12930
2,1 mH 66 mH	2,1 mH 66 mH	2,1 mH 10,3 mH	107 μ H 29,9 mH
3,9 Ω 30 Ω	3,9 Ω 30 Ω	3,9 Ω 4,7 Ω	0,2 Ω 16,4 Ω
10 Ω 18 kV	30 Ω 18 kV	- 18 kV	- 12 kV
2,84 A (p-p) 0,54 A (p-p)	2,82 A (p-p) 0,55 A (p-p)	2,84 A (p-p) 1,36 A (p-p)	9,7 A (p-p) 0,54 A (p-p)
43 cm (17 in), 110° 61 cm (24 in), 110°	43 cm (17 in), 110° 61 cm (24 in), 110°	61 cm (24 in), 110°	31 cm (12 in), 110°
AT2036/37	AT2036/37	AT2045/02	AT2072
AT4042/02	AT4042/02	AT4042/02	AT4072
-	-	AT1040/15	-



TERMINAL LOCATION

rear view

line deflection coils

field deflection coils

AT1020/01

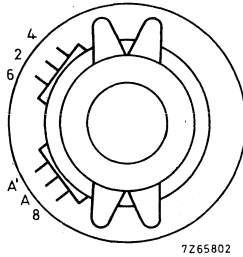

7265802

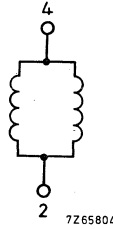

7265804

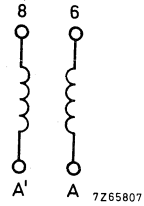

7265807



→ AT1038/00

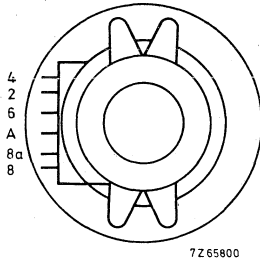

7265800

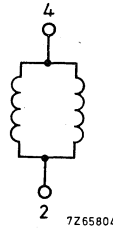

7265804

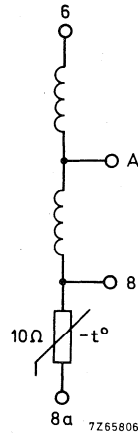

7265806

AT1040/00

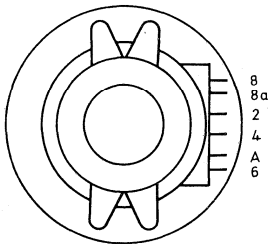

7265801

DEFLECTION UNITS

NON-PREFERRED TYPES

rear view

line deflection coils

field deflection coils

AT1040

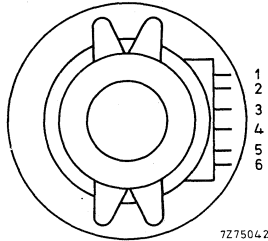

7275042

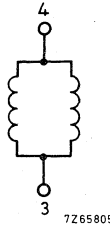

7265805

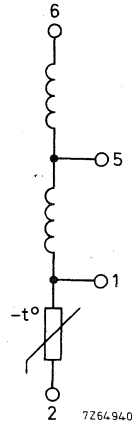

7264940

AT1040/03

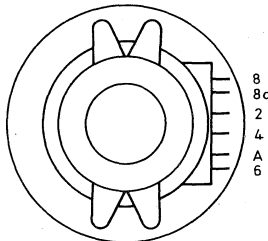

7265801

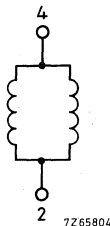

7265804

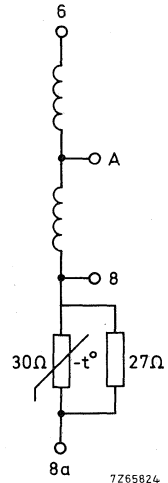

7265824



**NON-PREFERRED
TYPES**

DEFLECTION UNITS

rear view

line deflection coils

field deflection coils

AT1040/05

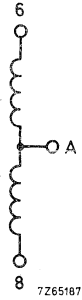
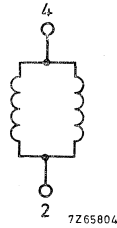
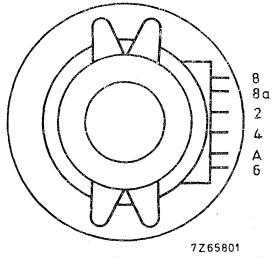

AT 1072

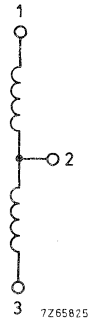
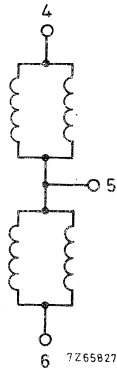
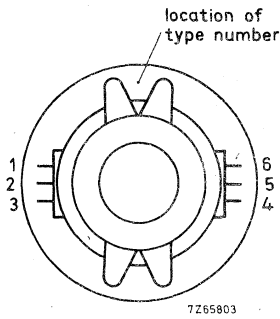

LINE OUTPUT TRANSFORMERS

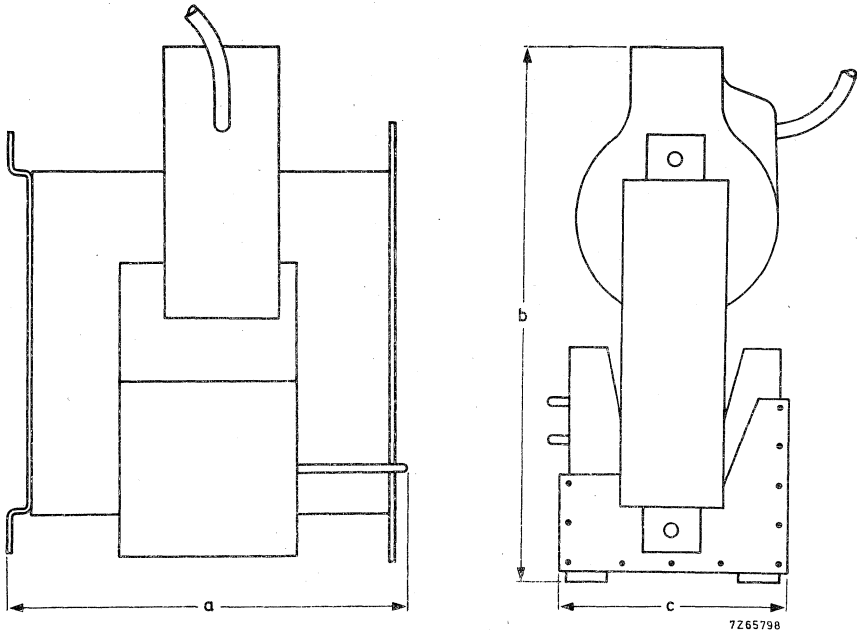

type	max. dimensions (mm) ¹⁾		
	a	b	c
AT2023/02	91	88,0	51,0
AT2025/01	66,5	90,2	40,2
AT2036/00	66,5	90,2	40,2
AT2036/10	66,5	90,2	40,2
AT2036/37	66,5	90,2	40,2
AT2042/01	59,3	83,0	40,2
AT2072	53,0	83,0	40,0

¹⁾ Protruding parts, e. g. brackets, included.

NON-PREFERRED TYPES

LINE OUTPUT TRANSFORMERS

Type number Catalogue number	AT2023/02 3122 108 39070		AT2025/01 3122 108 39100	
		pin		pin
I_{eht}	35 μ A		35 μ A	
E. H. T.	17,5 kV		18 kV	
$R_{i(eht)}$	< 4 M Ω		\leq 4,5 M Ω	
Supply voltage (V_B) current (I_B)	220 V 120 mA		240 V 100 mA	
I_{p-p} deflection	2,44 A (p-p)		2,44 A (p-p)	
Auxiliary windings	-300 V +300 V +330 V	1 3 4		
Scanning	625 lines, 50 frames 525 lines, 60 frames		625 lines, 50 frames 525 lines, 60 frames	
To be used with picture tube	43 cm (17 in), 110° 51 cm (20 in), 110° 61 cm (24 in), 110°		43 cm (17 in), 110° 51 cm (20 in), 110° 61 cm (24 in), 110°	
deflection unit adjustable linearity control unit	AT1038/00 AT4034/01	5 7	AT1038/00 AT4034/01	1 4
line output device	PL504	11	PL504	8
booster diode	PY88	10	PY88	7
e. h. t. rectifier	DY802		DY802	

LINE OUTPUT TRANSFORMERS

NON-PREFERRED
TYPES

AT2036/00 3122 138 30240		AT2036/10; AT2036/37 1)		AT2042/01 3122 107 30370		AT2072 3119 108 30600	
	pin		pin		pin		pin
35 μ A		35 μ A		35 μ A		35 μ A	
18 kV		18 kV		11 kV		10,2 kV	
$\leq 4,5 \text{ M}\Omega$		$\leq 6 \text{ M}\Omega$					
240 V		240 V		11 V		11 V	
109 mA		90 mA		520 mA		950 mA	
3 A (p-p)		3 A (p-p)		7,5 A (p-p)		8,2 A (p-p)	
		-110 V (p-p) } 1				+440 V (p-p)	12
		+110 V (p-p) } 2) 3				+110 V (p-p)	11
		+220 V (p-p) } 4				+25 V (p-p)	10
625 lines, 50 frames		625 lines, 50 frames		625 lines, 50 frames		625 lines, 50 frames	
525 lines, 60 frames		525 lines, 60 frames		525 lines, 60 frames		525 lines, 60 frames	
43 cm (17 in), 110°		43 cm (17 in), 110°		28 cm (11 in), 90°		31 cm (12 in), 110°	
51 cm (20 in), 110°		51 cm (20 in), 110°					
61 cm (24 in), 110°		61 cm (24 in), 110°					
AT1040	1 }	AT1040	5 }	AT1020/01	4 }	AT1072	3 }
AT4042/02	4 }	AT4042/02	8 }	AT4036	+	AT4072	4 }
PL504	8	PL504	12	BD160	3	BD160	2
PY88	7	PY88	11	BY118	4	BYX55	1
DY802		DY802/TV18S		DY51		stack	14

1) Catalogue number of AT2036/10: 3122 138 30100.
Catalogue number of AT2036/37: 3103 108 30170.

2) Only valid for AT2036/37.

TERMINAL LOCATION

AT2023/02

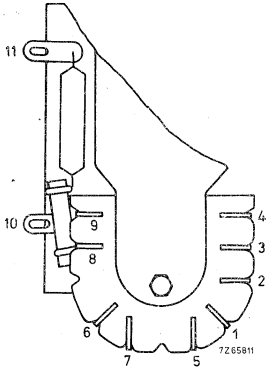

connecting pins

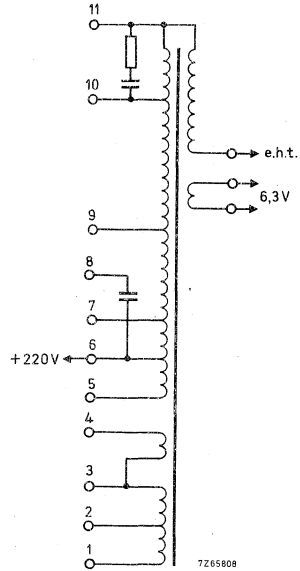

diagram

AT2025/01, AT2036/00 and AT2036/10

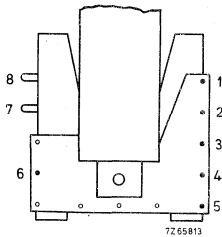

connecting pins

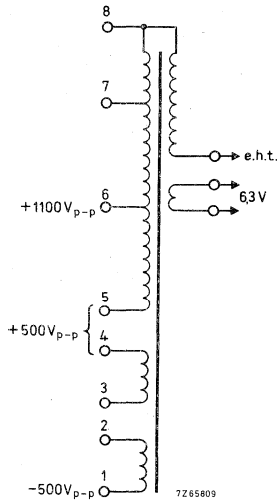

diagram

AT2036/37

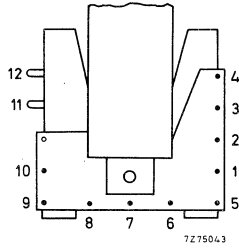

connecting pins

diagram

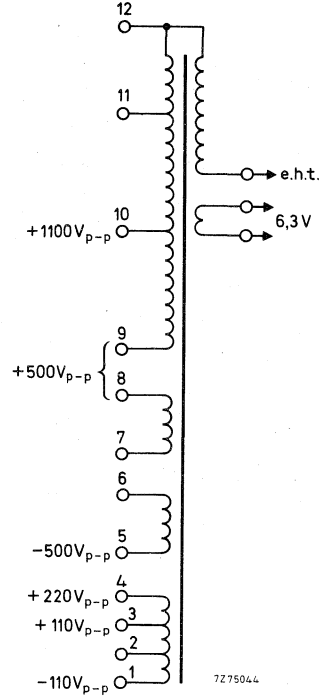

AT2042/01

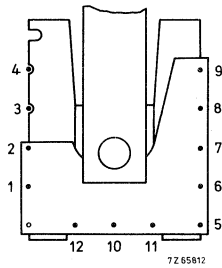

connecting pins

diagram

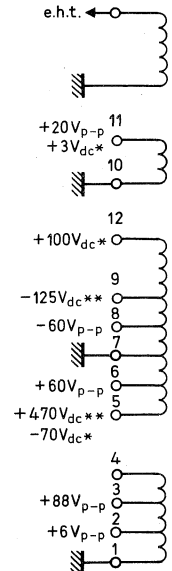

* rectified during scan

** rectified flyback pulse

**NON-PREFERRED
TYPES**

LINE OUTPUT TRANSFORMERS

AT2072

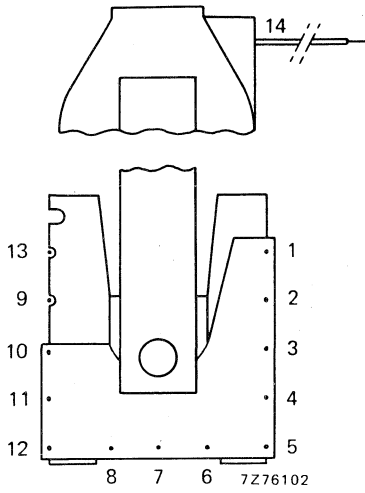

connecting pins

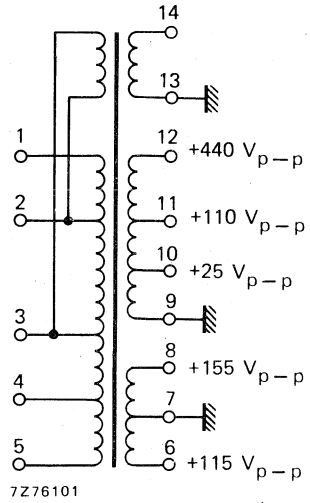

diagram

LINEARITY CONTROL UNITS

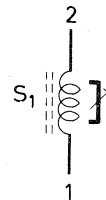
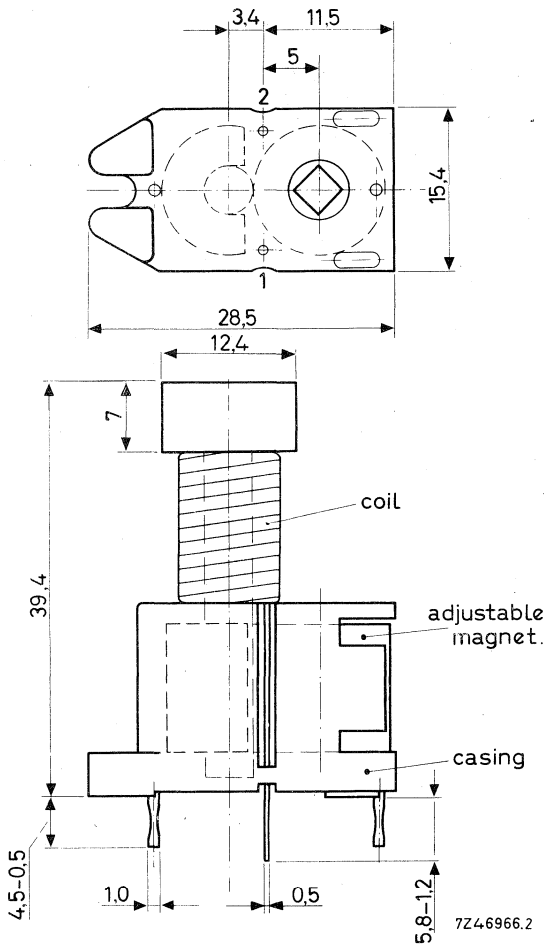

Fig. 1a. Dimensions in mm.

Fig. 1b. Circuit symbol.

AT4034/01 (Fig. 1)

Catalogue number 3122 108 39180.

To be used with deflection unit AT1038/00 and line output transformer AT2025/01.

When a saw-tooth current (without S-correction) of $2,4 A_{p-p}$, frequency 15625 Hz, flyback ratio 18%, flows through the linearity control unit (one connection point to earth), the correction voltage is adjustable between 12 V and 24 V.

E.H.T. SOCKETS FOR TUBE DY802

Dimensions in mm

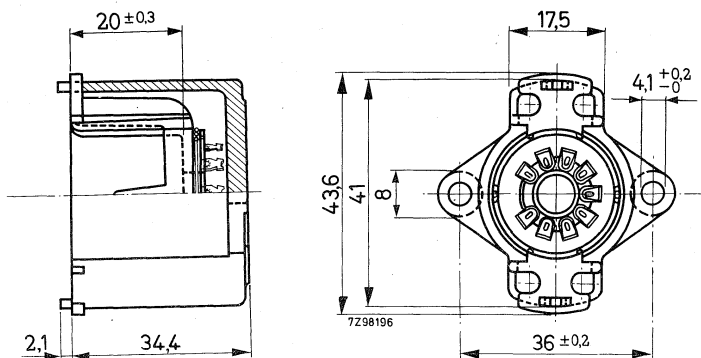

type	catalogue number	resistance value of series resistor in the heater circuit
AT7130	3122 107 77950	1,6 Ω
AT7130/01	3122 107 31240	1,2 Ω

Components for colour television



self-converging
system

A66-140X or A66-410X	A56-140X	A66-500X	A56-500X	A51-500X	A47-500X
110° delta 66 cm (26 in)	110° delta 56 cm (22 in)	110° in-line 66 cm (26 in)	110° in-line 56 cm (22 in)	110° in-line 51 cm (20 in)	110° in-line 47 cm (18 in)

PREFERRED TYPES

COLOUR PICTURE TUBE

deflection angle
gun arrangement
screen diagonal

BASIC DEFLECTION PACKAGE

deflection unit
line output transformer
diode-split line output
transformer

AT1062/01	AT1083/01	AT1085	AT1085
AT2063/00	AT2063/00	AT2080/10	AT2080/10
		or AT2076/10	

LINE DEFLECTION

driver transformer
centring choke
linearity control
E/W loading coil
bridge coil
balancing coil
phase adjuster
four-pole adjusting coil

AT4043/87	AT4043/87
AT4043/88	AT4042/17
AT4042/08	or AT4042/38
	AT4044/20
AT4043/86	AT4044/26
AT4040/85	AT4044/26
AT4040/87	AT4044/27

FIELD DEFLECTION

Class-D filter choke

AT4043/35

CONVERGENCE

convergence unit (3 x)

AT4046/27
or AT4046/28
or AT4046/32

bridge coil	AT1068/03	AT4043/38
blue lateral unit	or AT1068/04	
multi-pole unit	AT4040/44 (2x)	AT1081
convergence adjusters	AT4040/58	
	AT4040/61	
	AT4040/92	
	AT4040/93	

NORTH-SOUTH RASTER

transductor	AT4041/40	
correction coils	AT4040/31	
	AT4040/38	
	AT4040/87	

DESIGNED WITH

line-output device	BU208A	BU208A
E.H.T. rectifier/multiplier	BG1895 641	BG1895 641 (with AT2080/10)

DELAY LINES

system: PAL	DL50
PAL/SECAM	DL51
	DL52
Brazilian PAL	DL53
NTSC	DL55
PAL	DL60

The data sheets of these types are arranged according to their type numbers on the following pages.



NON-PREFERRED TYPES

Abridged data of the following types are given in tables which can be found after the data sheets of the preferred types.

Blue lateral units	AT1025/05
	AT1025/08
	AT1066/01
Deflection units	AT1027/07
	AT1027/09
	AT1029/07
	AT1029/09
	AT1060/01
Transductors	AT4041/08
	AT4041/14
	AT4041/15
	AT4041/37
Adjustable linearity control unit	AT4042/02
	AT4042/12
Convergence units	AT4045/07
	AT4045/08
	AT4046/07
	AT4046/08
	AT4050/11

DEFLECTION UNIT with purity ring

RZ 29829-1

RZ 28730-3

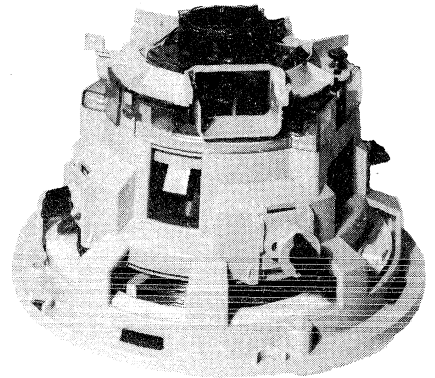
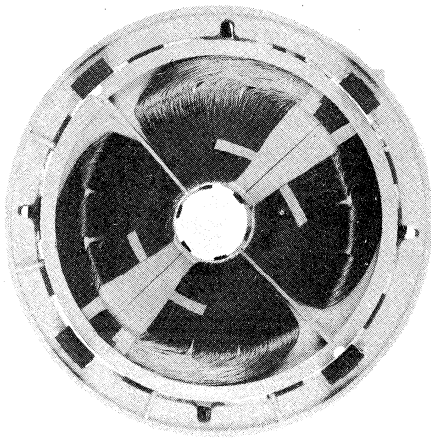

APPLICATION

This deflection unit has been designed for the 26 in 110⁰ shadow mask colour picture tubes A66-140X and A66-410X, to operate in conjunction with the following units:

Convergence units

AT4046/..
or AT4050/..

Line-output transformer

AT2063/.. combined with a tripler

Linearity control unit

AT4042/..

Blue lateral unit

AT1068/..

DESCRIPTION (see Fig. 1)

The unit AT1062/01 comprises the deflection unit AT1062 and the purity ring AT1061 which can easily be clipped to the back of the housing of the AT1062, 4), after this unit has been secured.

The saddle-shaped line and field deflection coils as well as the Ferroxcube yoke ring are supported by a Noryl ring. This set is built into a Noryl coaxial housing provided with four guide slots in which the set can be axially adjusted over a distance of 11,5 mm, 1). With the complete unit fastened on the neck of the picture tube, the coils can still be turned $\pm 4^{\circ}$ for correct raster orientation and displaced axially for purity adjustment. Two of the wing nut attachments 2) are grooved and spring-loaded to prevent unwanted turning of the coils during axial displacement.

Furthermore the housing is provided with attachments into which convergence units can easily be clipped. By loosening the screw in the rim of the housing, the convergence units can be rotated through 15° , 3).

→ The entire deflection unit meets the self-extinguishing requirements of IEC65 para. 14.1 and UL94, SE1.

To compensate for temperature dependence of the coils, the deflection unit is equipped with a built-in NTC thermistor which can be connected in series with the field deflection coils. In field output circuits with voltage feedback for linearizing the sawtooth, the picture height then remains almost constant up to 95°C .

MECHANICAL DATA

Dimensions in mm

Fig. 1

Mounting

The deflection unit is slid over the neck of the picture tube. It is brought into the correct position as indicated by marks on the housing of the unit and on the cone of the tube. The housing of the unit is fixed by means of the clamping bracket (at the rear) and screw (which must be tightened with a minimum torque of 1.5 Nm). During this operation the housing must be pressed against the cone so that the four friction shoes at the front of the unit rest against the cone of the picture tube. Then the purity ring is clicked to the back of the housing of the deflection unit. (Now the blue lateral unit can be mounted). Once the coil unit in the housing of the deflection unit is in its correct position, it is fixed by means of the four wing nuts.

ELECTRICAL DATA (typical values)

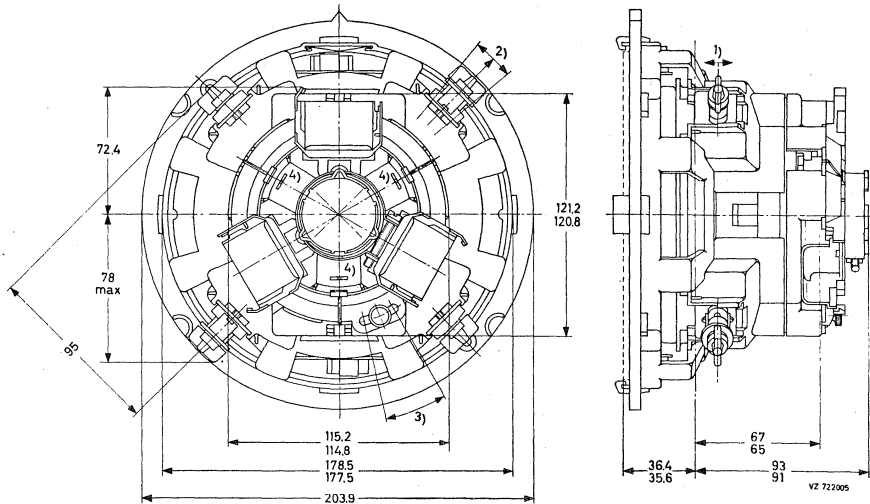
Line deflection coils, series connected (1 and 1' interconnected)

Inductance	4,7 mH
Resistance at 25 °C	3,5 Ω
Deflection current at 25 kV, edge to edge scan in both directions	3,0 A _p -p

Field deflection coils, series connected (4 and 4' interconnected)

Inductance	25 mH
Resistance at 25 °C	14,2 Ω + NTC (8 Ω)
Deflection current at 25 kV, edge to edge scan in both directions	1.2 A _p -p

Maximum working temperature 95 °C

Connections

The connection tags are plugable and solderable.

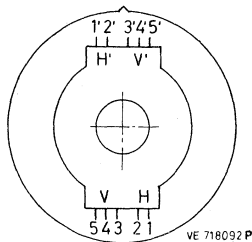

Fig. 2. Terminal location

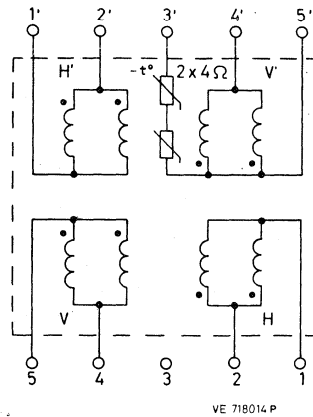

Fig. 3. Circuit diagram

H = line coils
V = field coils

Purity adjustment

The purity can be adjusted by means of the two independently movable annular magnets of the purity ring AT1061 (catalogue number 3122 107 50200), see Fig. 5. These magnets are diametrically magnetised. The units are supplied with the magnet fields opposing each other, giving minimum resultant field; the notches of the magnets then coincide. By turning the magnets with respect to each other the magnetic force of the resultant field of both magnets is adjusted. The direction of the resultant magnetic field is adjusted by turning the magnets simultaneously. The area of purity adjustment which can be obtained on the screen of the picture tube is given in Fig. 4 (dimensions in mm).

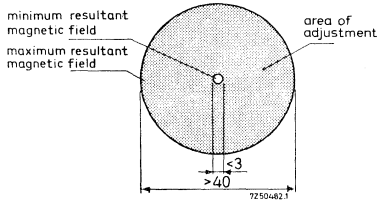
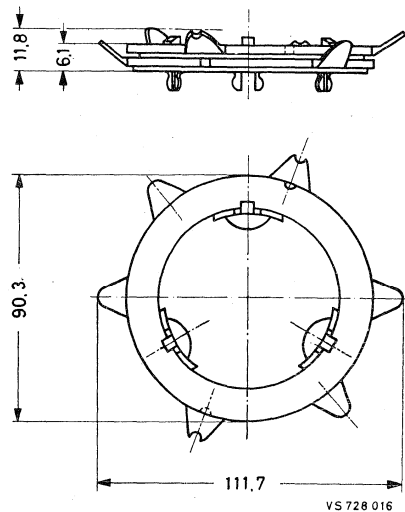

Fig. 4

Fig. 5. Dimensions in mm of
the purity ring AT1061

DEFLECTION UNIT

with purity ring

APPLICATION

This deflection unit has been designed for the 22 in 110° shadow mask colour picture tubes A56-140X and A56-410X, to operate in conjunction with the following units:

Convergence units	AT4046/.. or AT4050/..
Line output transformer	AT2063/.. combined with a tripler
Linearity control unit	AT4042/..
Blue lateral unit	AT1068/..

DESCRIPTION (see Fig. 1)

The unit AT1063/01 comprises the deflection unit AT1063 and the purity ring AT1061 which can easily be clipped to the back of the housing of the AT1063 ⁴⁾ after this unit has been secured.

The saddle-shaped line and field deflection coils as well as the Ferroxcube yoke ring are supported by a Noryl ring. This set is built into a Noryl coaxial housing provided with four guide slots in which the set can be axially adjusted over a distance of 11,5 mm ¹⁾. With the complete unit fastened on the neck of the picture tube, the coils can still be turned $\pm 4^\circ$ for correct raster orientation and displaced axially for purity adjustment. Two of the wing nut attachments ²⁾ are grooved and spring-loaded to prevent unwanted turning of the coils during axial displacement.

Furthermore the housing is provided with attachments into which convergence units can easily be clipped. By loosening the screw in the rim of the housing, the convergence units can be rotated through 15° ³⁾.

The entire deflection unit meets the self-extinguishing requirements of IEC65 para. 14.1 and UL94, SE1. ←

To compensate for temperature dependence of the coils, the deflection unit is equipped with a built-in NTC thermistor which can be connected in series with the field deflection coils. In field output circuits with voltage feedback for linearizing the sawtooth, the picture height then remains almost constant up to 95 °C.

MECHANICAL DATA

Dimensions (mm)

Fig. 1

Mounting

The deflection unit is slid over the neck of the picture tube. It is brought into the correct position as indicated by marks on the housing of the unit and on the cone of the tube. The housing of the unit is fixed by means of the clamping bracket (at the rear) and screw (which must be tightened with a minimum torque of 1,5 Nm). During this operation the housing must be pressed against the cone so that the four friction shoes at the front of the unit rest against the cone of the picture tube. Then the purity ring is clicked to the back of the housing of the deflection unit. (Now the blue lateral unit can be mounted). Once the coil unit in the housing of the deflection unit is in its correct position, it is fixed by means of the four wing nuts.

ELECTRICAL DATA (typical values)

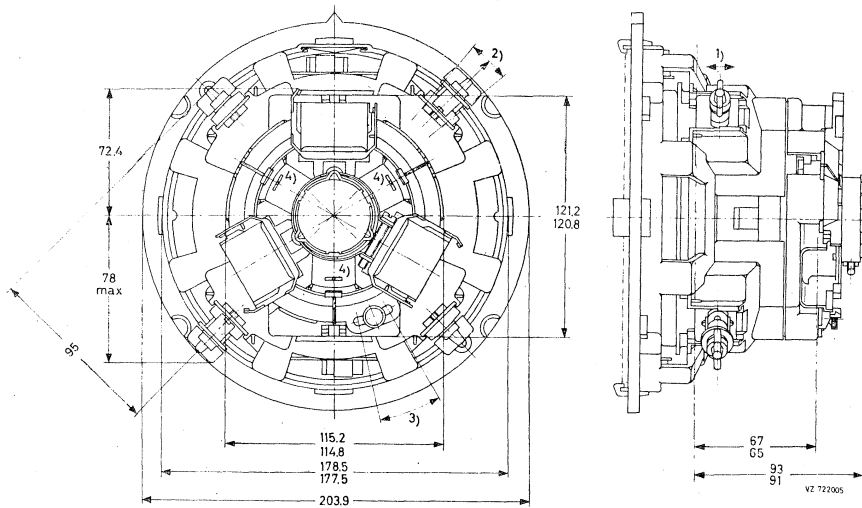
Line deflection coils, series connected (1 and 1' interconnected)

Inductance	4,7 mH
Resistance at 25 °C	3,5 Ω
Deflection current at 25 kV, edge to edge scan in both directions	3,0 A p-p

Field deflection coils, series connected (4 and 4' interconnected)

Inductance	25 mH
Resistance at 25 °C	14,2 Ω + NTC (8 Ω)
Deflection current at 25 kV, edge to edge scan in both directions	1,2 A p-p

Maximum working temperature 95 °C

Connections

The connection tags are plugable and solderable.

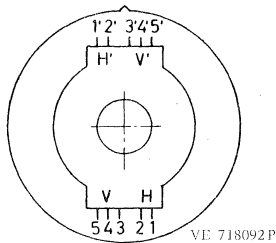

Fig. 2 Terminal location

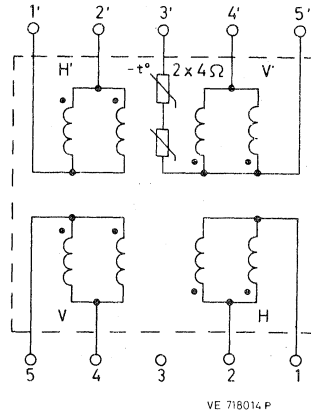

Fig. 3 Circuit diagram

H = line coils
V = field coils

Purity adjustment

The purity can be adjusted by means of the two independently movable annular magnets of the purity ring AT1061 (catalogue number 3122 107 50200), see Fig. 5. These magnets are diametrically magnetised. The units are supplied with the magnet fields opposing each other, giving minimum resultant field; the notches of the magnets then coincide. By turning the magnets with respect to each other the magnetic force of the resultant field of both magnets is adjusted. The direction of the resultant magnetic field is adjusted by turning the magnets simultaneously. The area of purity adjustment which can be obtained on the screen of the picture tube is given in Fig. 4 (dimensions in mm).

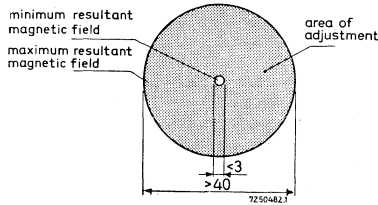

Fig. 4

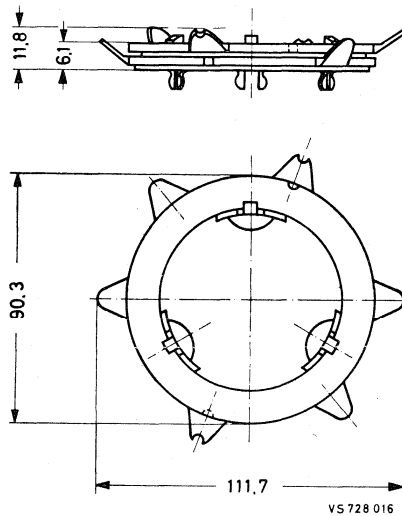

Fig. 5 Dimensions in mm of the purity ring AT1061.

BLUE LATERAL UNIT

APPLICATION

This unit is intended for use with a 110° shadow mask colour picture tube in conjunction with:

a deflection unit AT1060/..

or AT1062/..

or AT1063/..

and convergence units AT4046/..

or AT4050/..

for static and dynamic blue lateral adjustment.

MECHANICAL DATA

Dimensions (mm)

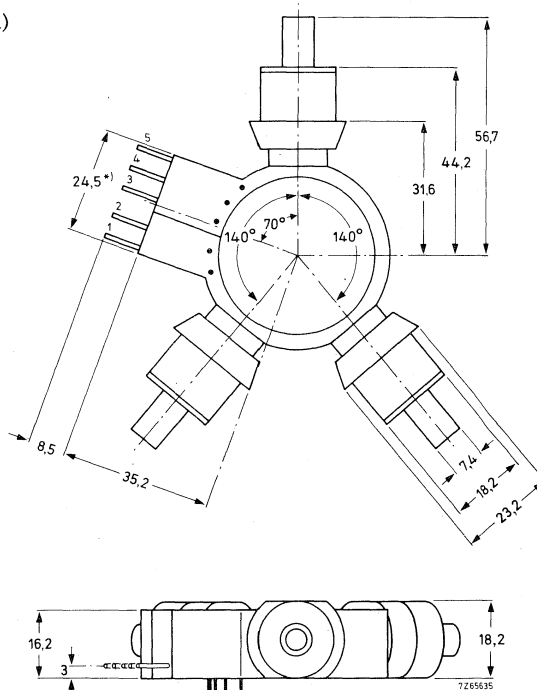

Fig. 1

The unit is self-clamping around a tube with a diameter of $36,5 \pm 1,6$ mm.

*) This dimension is minimum and will be larger when the unit is in position.

ELECTRICAL DATA

Coils for static adjustment

terminals	1 and 5
support terminal for NTC thermistor	4
resistance	19,3 Ω
inductance	23,4 mH

Coils for dynamic adjustment

terminals	2 and 3
resistance	2,15 Ω
inductance	300 μH

Maximum working temperature 95 °C

Static lateral adjustment

Static lateral adjustment in the centre of a 110° picture tube A66-140X or A56-140X can be obtained with a d.c. current of 90 mA. This gives a minimum adjustment range of 5 mm.

Dynamic lateral adjustment

A horizontal shift in the points B and C (see Fig. 2) between red/green and blue of $\geq 3,5$ mm can be obtained with a saw-tooth current of 840 mA p-p, frequency 15 kHz, through the coils (terminals 2 and 3).

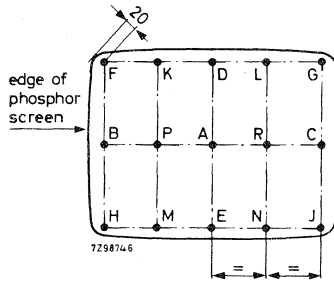

Fig. 2

BLUE LATERAL UNIT

APPLICATION

This unit is intended for use with a 110° shadow mask colour picture tube in conjunction with:

- a deflection unit AT1060/..
- or AT1062/..
- or AT1063/..
- and convergence units AT4046/..
- or AT4050/..

for static and dynamic blue lateral adjustment.

MECHANICAL DATA

Dimensions (mm)

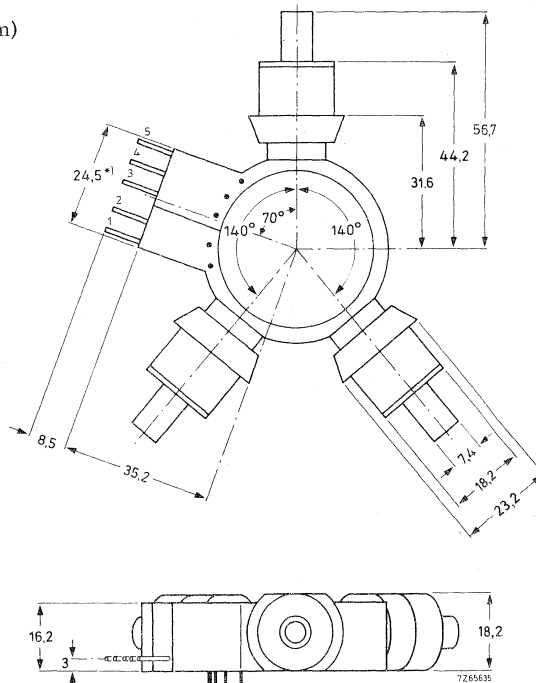

Fig. 1

The unit is self-clamping around a tube with a diameter of $36,5 \pm 1,6$ mm.

*) This dimension is minimum and will be larger when the unit is in position.

ELECTRICAL DATA

Coils for static adjustment

terminals	1 and 5
support terminal for NTC thermistor	4
resistance	198,5 Ω
inductance	215 mH

Coils for dynamic adjustment

terminals	2 and 3
resistance	2,15 Ω
inductance	300 μ H

Maximum working temperature 95 °C

Static lateral adjustment

Static lateral adjustment in the centre of a 110° picture tube A66-140X or A56-140X can be obtained with a d.c. current of 27,5 mA. This gives a minimum adjustment range of 6,5 mm.

Dynamic lateral adjustment

A horizontal shift in the points B and C (see Fig. 2) between red/green and blue of $\geq 3,5$ mm can be obtained with a saw-tooth current of 840 mA p-p, frequency 15 kHz, through the coils (terminals 2 and 3).

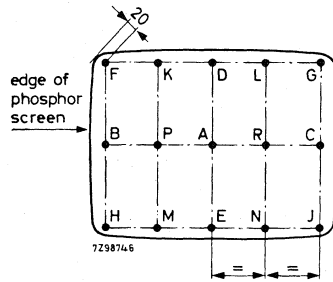

Fig. 2

DEFLECTION UNIT

with built-in 4-pole coils for symmetrizing
of the line and field astigmatism

QUICK REFERENCE DATA

Picture tube, gun arrangement	in line
diagonal	66 cm (26 in)
neck diameter	36,5 mm
Deflection angle	110°
Line deflection current, edge to edge at 25 kV	6,35 A p-p
Inductance of line coils, parallel connected	1,11 mH
Field deflection current, edge to edge at 25 kV	3,4 A p-p
Resistance of field coils, series connected	3,0 Ω
4-pole coils, sensitivity	
for line	± max. 34 mm/A
for field	± max. 23 mm/A
resistance (series connected)	1,6 Ω

APPLICATION

This deflection unit has been designed for use with a 110° colour picture tube type A66-500X in CTV receivers in conjunction with:

diode-split line output transformer	AT2076/10 and
line output transistor	BU208A
linearity control unit	AT4042/17 or AT4042/38
multipole unit	AT1081

DESCRIPTION (see Fig. 1)

The saddle-shaped line and field deflection coils, and the Ferroxcube yoke ring with 4-pole unit, are supported by a plastic cap. This set is built into a plastic coaxial housing, which is provided with a plastic axial alignment ring. This ring enables the set to be axially adjusted over a distance of 6 mm, after the complete unit has been fastened on the neck of the picture tube with a clamping ring. The screw of the clamping ring is accessible with a screwdriver via a recess in the axial alignment ring. To correct the raster orientation with the complete unit in position on the picture tube neck, the coil assembly can be rotated by means of the protruding parts on the supporting ring, which can be reached by the top and bottom recesses in the coaxial housing. The whole coil assembly is locked in the required position by pushing the levers down until they block.

The unit meets the self-extinguishing requirements of IEC65 para. 14.4 and UL94, SE1

MECHANICAL DATA

Dimensions in mm

Outlines

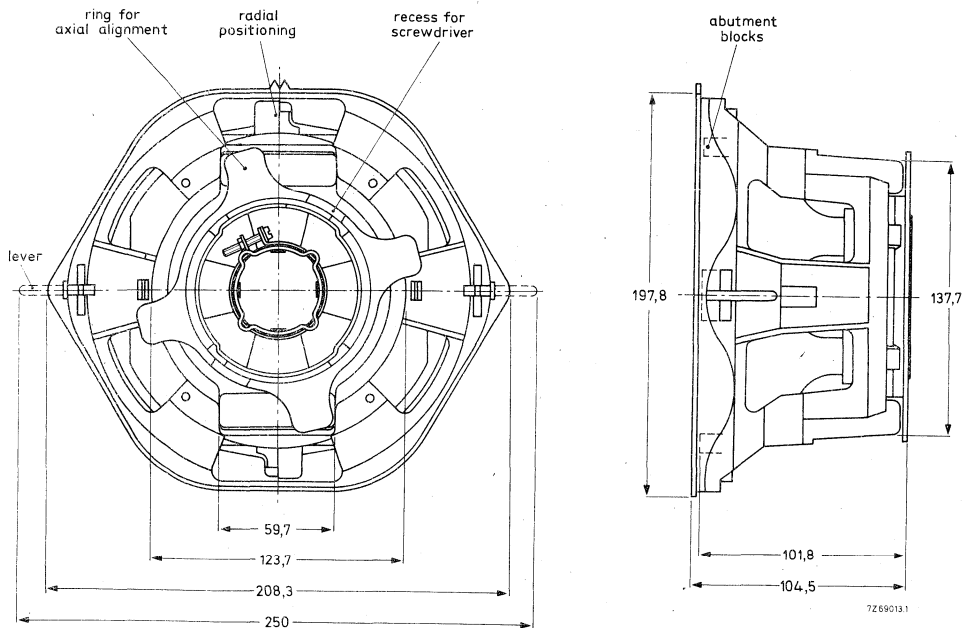

Fig. 1

The unit is provided with soldering pins for connection.

MOUNTING

To obtain easy reproducible and accurate alignment of the picture tube and the deflection unit, the cone of the picture tube has a moulded indexing ridge to centre the deflection unit housing.

The deflection unit is brought into correct position by alignment of the protrusion on the housing with the location mark on the cone of the tube.

The unit must be pressed against the cone, so that the housing is indexed by the moulded ridge on the cone. The unit is then fixed by tightening the screw in the clamping ring at the rear. The screw should be tightened with a torque of 1,2 to 1,4 Nm.

ELECTRICAL DATA

Line coils, parallel connected	
inductance	1,11 mH \pm 4%
resistance at 25 °C	1,2 Ω \pm 10%
Line deflection current, edge to edge at 25 kV	6,35 A p-p
Field coils, series connected	
inductance	3,5 mH \pm 10%
resistance at 25 °C	3,0 Ω \pm 7%
Field deflection current, edge to edge at 25 kV	3,35 A p-p
4-pole coils, sensitivity	
for line	\pm max. 34 mm/A
for field	\pm max. 23 mm/A
resistance (series connected)	1,6 Ω
Maximum operating temperature	95 °C

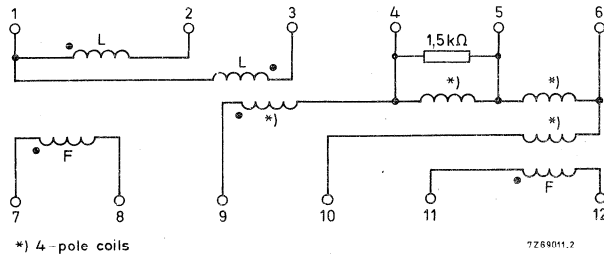
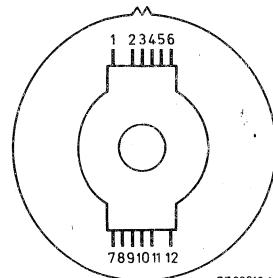

Fig. 2. Connection diagram.

L = Line
F = Field

Fig. 3. Terminal location.

The pin numbering corresponds to that in Fig. 2.



BEAM CORRECTIONS

With the deflection unit AT1080 and the **multipole** unit AT1081 mounted on the tube A66-500X, the following corrections may be required:

Maximum required horizontal displacement of the electron beams with respect to the phosphor stripes by the purifying magnet of the AT1081 1) 45 μm

Static convergence deviations must be corrected by the adjustable four-pole and six-pole fields of the AT1081 centred around the tube axis.

Maximum required compensation for static convergence
 4-pole device: red opposite to blue (in any direction) 6 mm
 6-pole device: red and blue to green (in any direction) 3 mm

North-South raster shape correction circuitry is not required.

To obtain a symmetrical shape for the horizontal lines at the upper and lower parts of the screen, the unit AT1081 comprises an additional two-pole correction magnet giving a displacement of the beam in the centre of the screen in vertical direction of maximum 5 mm

Maximum centring error in any direction after colour-purity, static convergence, and horizontal centre line correction 5 mm

With respect to dynamic convergence, the display system, consisting of picture tube A66-500X and deflection and AT1080, is inherently self converging. However, a small systematic correction is required on the vertical axis, and also small corrections should be made to compensate for tolerances and asymmetries in the tube and deflection unit combination. For this purpose two types of dynamic magnetic four-pole fields can be used, see Fig. 4. One is generated by additional windings on the yoke ring of the deflection unit energized by adjustable sawtooth currents synchronized with scanning.

The other type is generated by sawtooth and parabolic currents which are synchronized with scanning and flow through the deflection coils.

Compensation to be provided by these corrections:

- horizontal red-to-blue distance at the end of the horizontal axis (line symmetry) 2) $0 \pm 2 \text{ mm}$
- horizontal red-to-blue distance at the top of the vertical axis (field symmetry top) 3) $3,5 \pm 1,5 \text{ mm}$
- horizontal red-to-blue distance at the bottom of the vertical axis (field symmetry bottom) 3) $3,5 \mp 1,5 \text{ mm}$
- vertical red-to-blue distance at the ends of the horizontal axis in opposite directions (line balance) 4) $0 \pm 1,5 \text{ mm}$
- vertical red-to-blue distance at the ends of the horizontal axis in equal directions (line balance parabola) 5) $0 \pm 0,7 \text{ mm}$
- vertical red-to-blue distance at the top of the vertical axis (field balance top) 6) $0 \pm 1,5 \text{ mm}$
- vertical red-to-blue distance at the bottom of the vertical axis (field balance bottom) 7) $0 \pm 1,5 \text{ mm}$

Notes see next page.

Notes

- 1) Purity adjustment in vertical direction is not required.
- 2) This correction is made by feeding a sawtooth current of line frequency through the additional four-pole windings on the deflection unit.
- 3) This correction is made by feeding a rectified sawtooth current of field frequency through the additional four-pole windings on the deflection unit.
- 4) This correction is made by unbalancing the line deflection coils.
- 5) This correction is made by feeding a parabolic current of line frequency through the line deflection coils.
- 6) This correction is made by unbalancing the field deflection coils during the first half of the field scan.
- 7) This correction is made by unbalancing the field deflection coils during the second half of the field scan.

Application information available on request.



MULTI-POLE UNIT

QUICK REFERENCE DATA		
Horizontal beam displacement for colour purity (2 - pole)		for undeflected beams min. 45 μ m
Static convergence red opposite to blue in any direction (4-pole)	min.	8 mm
red-blue with respect to green in any direction (6 - pole)	min.	4 mm
Vertical displacement for optimum straightness of the horizontal lines (2 - pole)	min.	5 mm

APPLICATION

This unit has been designed for the colour picture tubes A66-500X, A56-500X, A51-500X and A47-500X, with in-line gun arrangement and the deflection units AT1080, AT1083/01 and AT1085. Its purpose is threefold:

- horizontal colour-purity adjustment
- static convergence adjustment
- adjustment of raster symmetry in N and S or adjustment of the horizontal axis for optimum straightness.

DESCRIPTION

The unit incorporates four ring-shaped permanent magnets, supported by non-magnetic plastic support rings, and a cam-actuated collet, which enables the unit to be clamped to the neck of the picture tube.

The magnetic rings are made up of an inner and an outer ring coupled by non-magnetic pinion gears to form an epicyclic train. The support rings carry the pinion gears.

The magnetic rings comprise:

- two pairs of 2-pole magnets
- one pair of 4-pole magnets
- one pair of 6-pole magnets

(each pair consisting of an inner and outer ring of identical magnetic configuration).

The support rings of both the 2-pole rings are fixed to the collet, those of the 4- and 6-pole rings are rotatable. Rotating the lug on an outer magnetic ring varies the resultant field strength.

Rotating the lug on a support ring varies the direction of the resultant field.

MECHANICAL DATA

Dimensions (mm)

See Fig. 1 on next page.

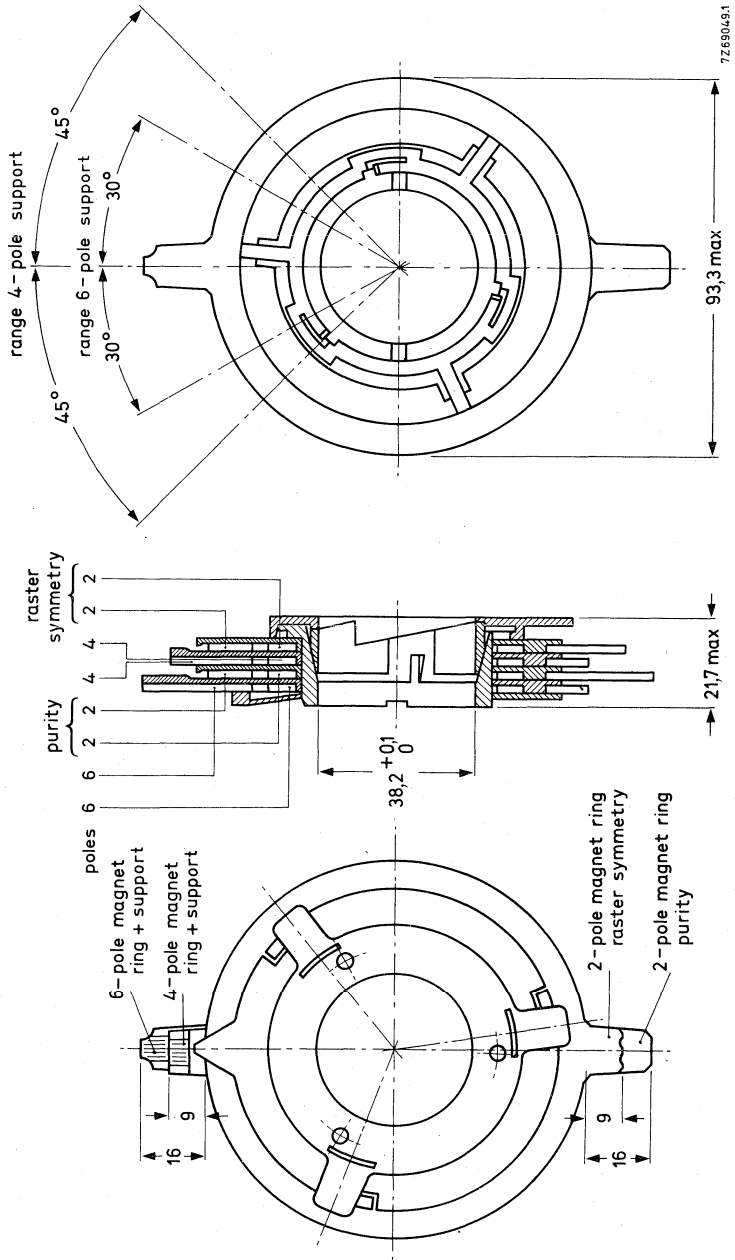

Fig.1

Mounting

Before mounting the multi-pole unit, the lug on the rear end of the collet must be rotated anti-clockwise. The unit is slid over the neck of the picture tube and pressed to the deflection unit.

Two protrusions on the front of the unit and the corresponding recesses on the back of the deflection unit, will bring the unit into correct position. By rotating the lug on the collet clockwise the unit will be clamped.

ADJUSTMENTS

Horizontal colour purity is obtained by varying the field strength of the 2-pole magnet situated between the 4-pole and 6-pole magnets (see Figs 1 and 2).

Vertical colour purity adjustment is not required (see data on colour picture tubes).

The static convergence is adjusted by varying the field strength and direction of the 4-pole and 6-pole. The 4-pole field moves the outer electron beams (red and blue) equally in opposite directions (see Fig.3). The 6-pole field moves the outer electron beams equally in the same direction (see Fig. 4). The centre beam (green) is unaffected. Horizontal axis or raster symmetry is adjusted by varying the field strength of the 2-pole magnet situated at the rear of the unit (see Fig. 1). All three beams are equally moved in a vertical direction (see Fig. 5).

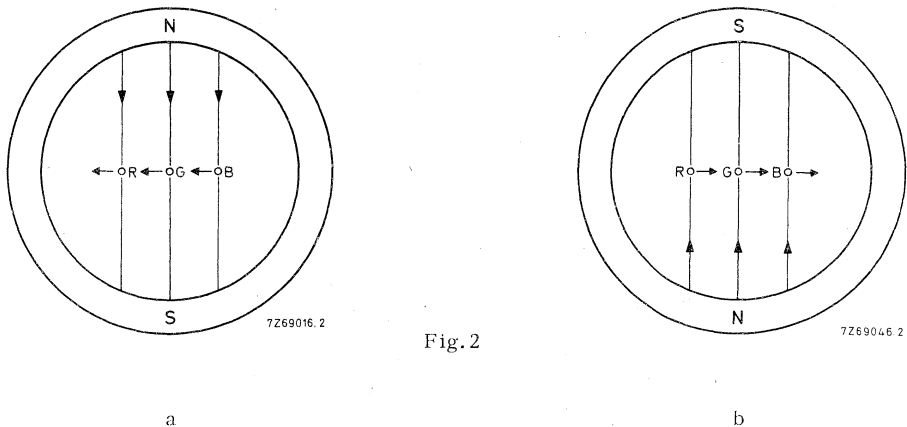
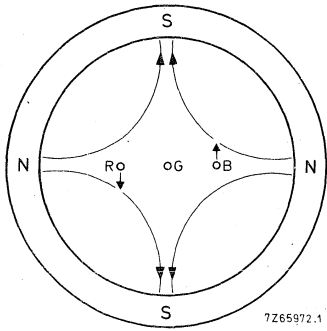
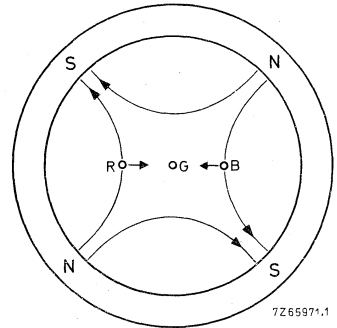

Fig. 2



7Z65972.1

a



7Z65971.1

b

Fig. 3

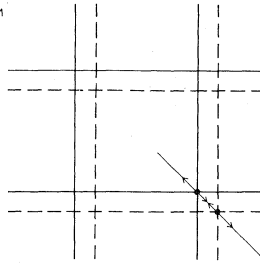

— red
- - - blue

7Z69047.2

c

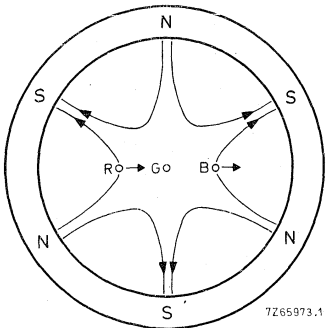

7Z65973.1

a

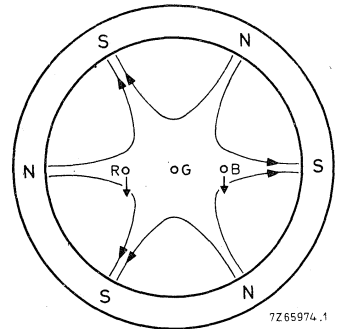

7Z65974.1

b

Fig. 4

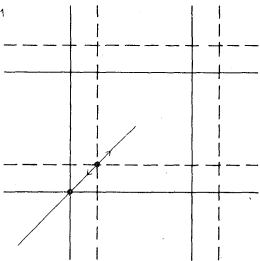

— green
- - - red - blue

7Z69048.1

c

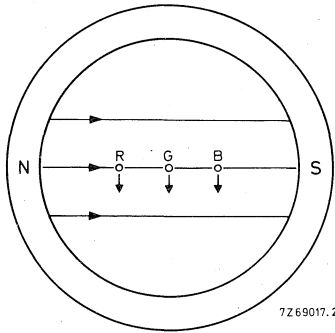

a

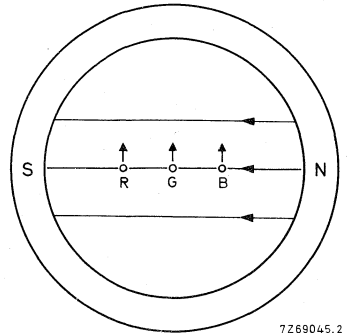

b

Fig. 5



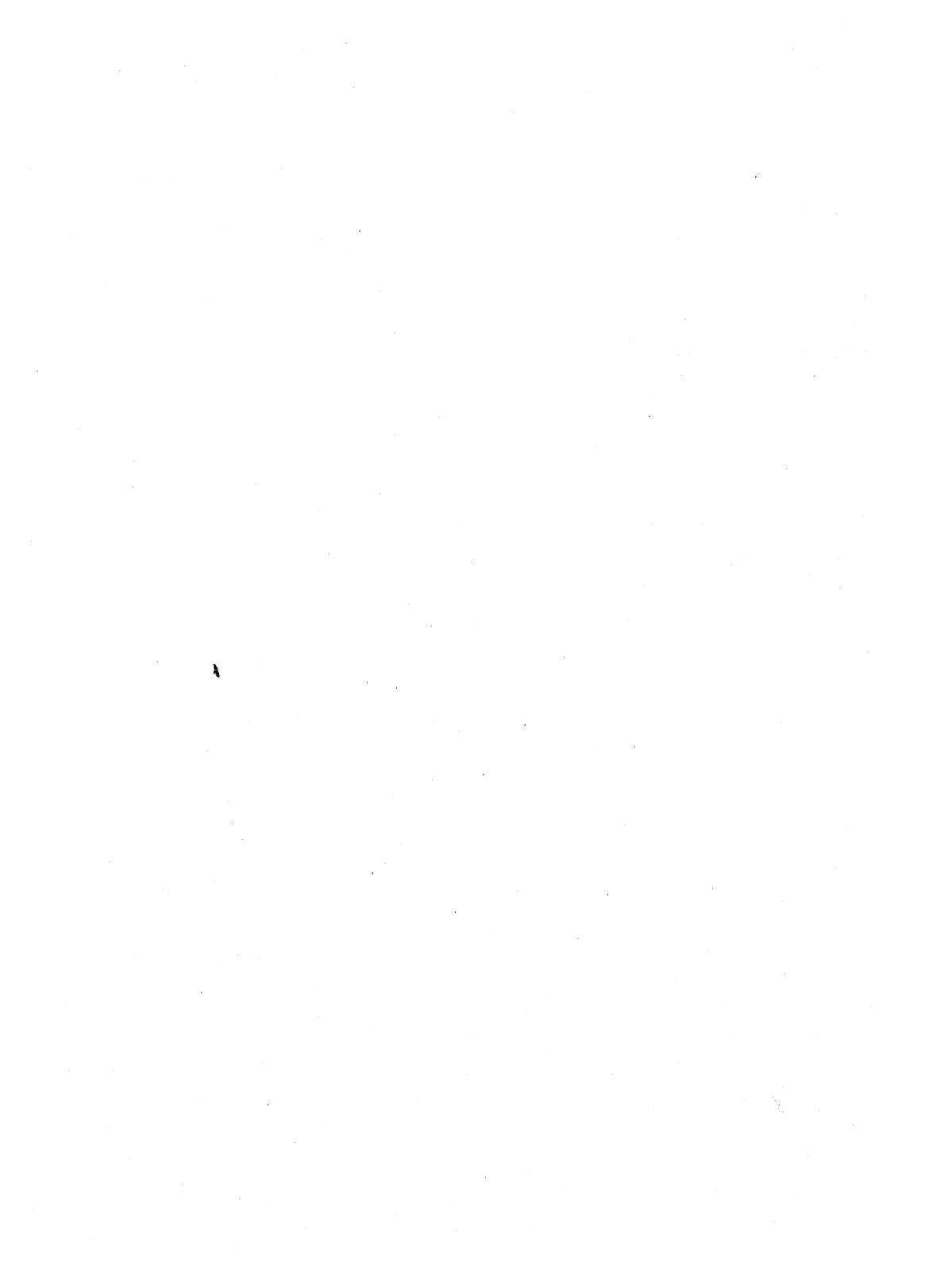

DEFLECTION UNIT

with built-in 4-pole coils for symmetrizing
of the line and field astigmatism

QUICK REFERENCE DATA

Picture tube, gun arrangement	in line
diagonal	55 cm (22 in)
neck diameter	36,5 mm
Deflection angle	110°
Line deflection current, edge to edge at 25 kV	6,2 A p-p
Inductance of line coils, parallel connected	1,14 mH
Field deflection current, edge to edge at 25 kV	3,4 A p-p
Resistance of field coils, series connected	3,36 Ω
4-pole coils, sensitivity	
for line	± max. 25 mm/A
for field	± max. 18 mm/A
resistance (series connected)	1,4 Ω

APPLICATION

This deflection unit has been designed for use with a 110° colour picture tube type A56-500X in CTV receivers in conjunction with:

diode-split line output transformer	AT2076/10 and
line output transistor	BU208A
linearity control unit	AT4042/17 or AT4042/38
multipole unit	AT1081



DESCRIPTION (see Fig. 1)

The saddle-shaped line and field deflection coils, and the Ferroxcube yoke ring with 4-pole unit, are supported by a plastic cap. This set is built into a plastic coaxial housing, which is provided with a plastic axial alignment ring. This ring enables the set to be axially adjusted over a distance of 5 mm, after the complete unit has been fastened on the neck of the picture tube with a clamping ring. The screw of the clamping ring is accessible with a screwdriver via a recess in the axial alignment ring. To correct the raster orientation with the complete unit in position on the picture tube neck, the coil assembly can be rotated by means of the protruding parts on the supporting ring, which can be reached by the top and bottom recesses in the coaxial housing. The whole coil assembly is locked in the required position by pushing the levers down until they block.

The unit meets the self-extinguishing requirements of IEC 65 para. 14.4 and UL94, SE 1.

MECHANICAL DATA

Dimensions in mm

Outlines

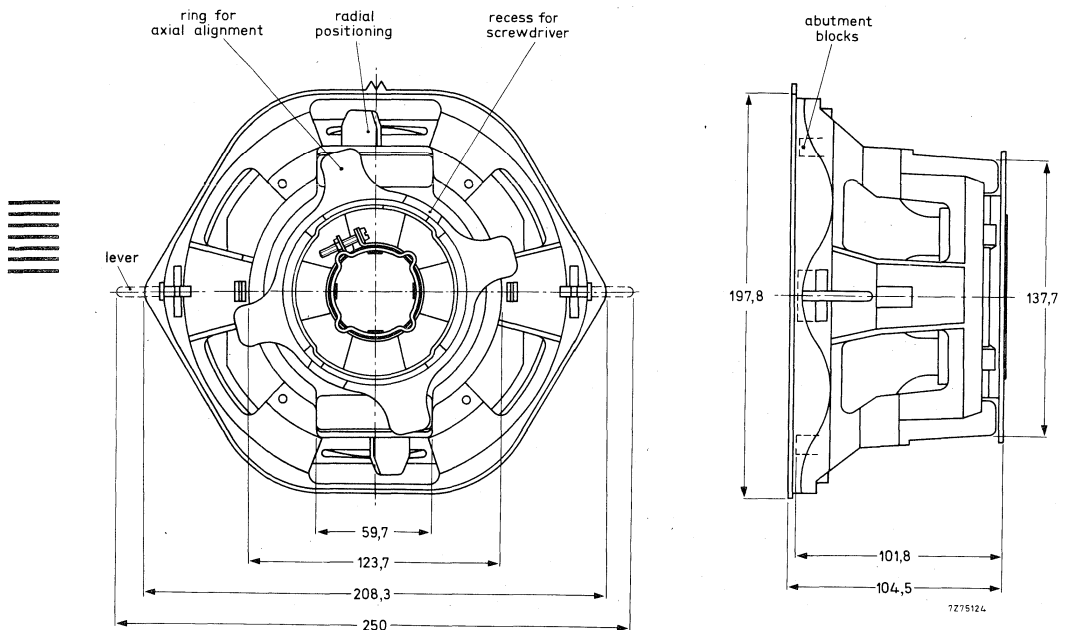

Fig. 1

The unit is provided with soldering pins for connection.

MOUNTING

To obtain easy reproducible and accurate alignment of the picture tube and the deflection unit, the cone of the picture tube has a moulded indexing ridge to centre the deflection unit housing.

The deflection unit is brought into correct position by alignment of the protrusion on the housing with the location mark on the cone of the tube.

The unit must be pressed against the cone, so that the housing is indexed by the moulded ridge on the cone. The unit is then fixed by tightening the screw in the clamping ring at the rear. The screw should be tightened with a torque of 1, 2 to 1, 4 Nm.

ELECTRICAL DATA

Line coils, parallel connected

inductance

1,14 mH \pm 4%

resistance at 25 °C

0,9 Ω \pm 10%

Line deflection current, edge to edge at 25 kV

6,24 A p-p

Field coils, series connected

inductance

3,9 mH \pm 10%

resistance at 25 °C

3,36 Ω \pm 7%

Field deflection current, edge to edge at 25 kV

3,4 A p-p

4-pole coils, sensitivity

for line

\pm max. 25 mm/A

for field

\pm max. 18 mm/A

resistance (series connected)

1,4 Ω

Maximum operating temperature

95 °C

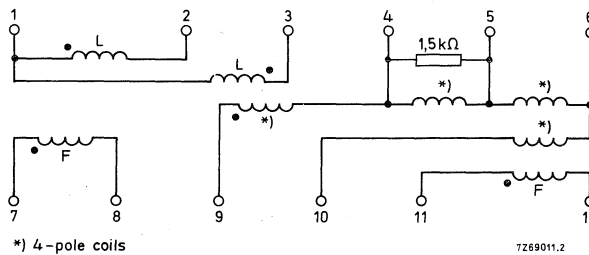

Fig. 2. Connection diagram.

L = Line

F = Field

Fig. 3. Terminal location.

The pin numbering corresponds to that in Fig. 2.

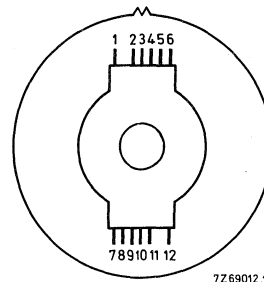

BEAM CORRECTIONS

With the deflection unit AT1083/01 and the multipole unit AT1081 mounted on the tube A56-500X, the following corrections may be required:

Maximum required horizontal displacement of the electron beams with respect to the phosphor stripes by the purifying magnet of the AT1081¹⁾ 45 μm

Static convergence deviations must be corrected by the adjustable four-pole and six-pole fields of the AT1081 centred around the tube axis.

Maximum required compensation for static convergence
 4-pole device: red opposite to blue (in any direction) 5,5 mm
 6-pole device: red and blue to green (in any direction) 2,8 mm

North-South raster shape correction circuitry is not required.

To obtain a symmetrical shape for the horizontal lines at the upper part and the lower part of the screen, the unit AT1081 comprises an additional two-pole correction magnet giving a displacement of the beam in the centre of the screen in vertical direction of maximum 4,5 mm

Maximum centring error in any direction after colour-purity, static convergence, and horizontal centre line correction 4,5 mm

With respect to dynamic convergence, the display system, consisting of picture tube A56-500X and deflection unit AT1083/01 is inherently self converging. However, small corrections should be made to compensate for tolerances and asymmetries in the tube and deflection unit combination.

For this purpose two types of dynamic magnetic four-pole fields can be used. One is generated by additional windings on the yoke ring of the deflection unit energized by adjustable sawtooth currents synchronized with scanning. The other type is generated by sawtooth and parabolic currents which are synchronized with scanning and flow through the deflection coils.

Compensation to be provided by these corrections:

- horizontal red-to-blue distance at the end of the horizontal axis (line symmetry) 2) 0 ± 1,5 mm
- horizontal red-to-blue distance at the ends of the vertical axis (field symmetry) 3) ± 1,5 mm
- vertical red-to-blue distance at the ends of the horizontal axis in opposite directions (line balance) 4) 0 ± 1,0 mm
- vertical red-to-blue distance at the ends of the horizontal axis in equal directions (line balance parabola) 5) 0 ± 0,6 mm
- vertical red-to-blue distance at the top of the vertical axis (field balance top) 6) 0 ± 1,2 mm
- vertical red-to-blue distance at the bottom of the vertical axis (field balance bottom) 7) 0 ± 1,2 mm

Notes see next page.

Notes

- 1) Purity adjustment in vertical direction is not required.
- 2) This correction is made by feeding a sawtooth current of line frequency through the additional four-pole windings on the deflection unit.
- 3) This correction is made by feeding a rectified sawtooth current of field frequency through the additional four-pole windings on the deflection unit.
- 4) This correction is made by unbalancing the line deflection coils.
- 5) This correction is made by feeding a parabolic current of line frequency through the line deflection coils.
- 6) This correction is made by unbalancing the field deflection coils during the first half of the field scan.
- 7) This correction is made by unbalancing the field deflection coils during the second half of the field scan.

Application information available on request.



DEFLECTION UNIT

with built-in 4-pole coils for symmetrizing
of the line and field astigmatism

QUICK REFERENCE DATA

Picture tube, gun arrangement	in line	
diagonal	51 cm (20 in) or 47 cm (18 in)	
neck diameter	36,5 mm	
Deflection angle	110°	
Line deflection current, edge to edge at 25 kV	6,2 A p-p	
Inductance of line coils, parallel connected	1,14 mH	
Field deflection current, edge to edge at 25 kV	3,4 A p-p	
Resistance of field coils, series connected	3,36 Ω	
4-pole coils, sensitivity	A51-500X	A47-500X
for line	± max. 23 mm/A	21 mm/A
for field	± max. 16 mm/A	15 mm/A
resistance (series connected)	1,4 Ω	

APPLICATION

This deflection unit has been designed for use with 110° colour picture tubes.
A51-500X and A47-500X in CTV receivers in conjunction with:

diode-split line output transformer	AT2076/10 and
line output transistor	BU208A
linearity control unit	AT4042/17 or AT4042/38
multipole unit	AT1081

DESCRIPTION (see Fig. 1)

The saddle-shaped line and field deflection coils, and the Ferroxcube yoke ring with 4-pole unit, are supported by a plastic cap. This set is built into a plastic coaxial housing, which is provided with a plastic axial alignment ring. This ring enables the set to be axially adjusted over a distance of 5 mm, after the complete unit has been fastened on the neck of the picture tube with a clamping ring. The screw of the clamping ring is accessible with a screwdriver via a recess in the axial alignment ring. To correct the raster orientation with the complete unit in position on the picture tube neck, the coil assembly can be rotated by means of the protruding parts on the supporting ring, which can be reached by the top and bottom recesses in the coaxial housing. The whole coil assembly is locked in the required position by pushing the levers down until they block.

The unit meets the self-extinguishing requirements of IEC65 para. 14.4 and UL94, SE1.

MECHANICAL DATA

Dimensions in mm

Outlines

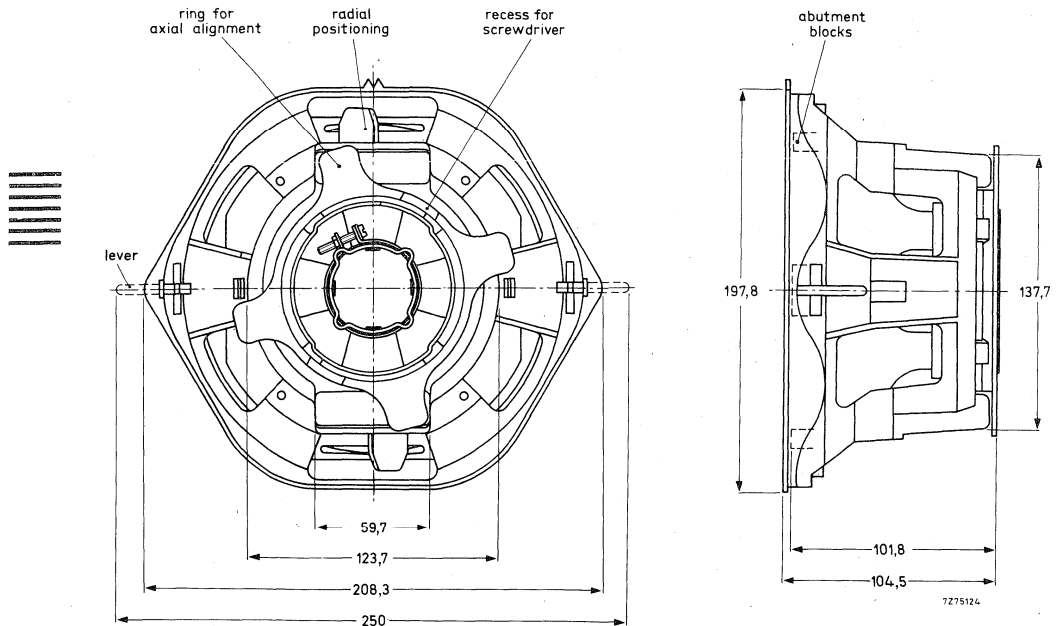

Fig. 1

The unit is provided with soldering pins for connection.

MOUNTING

To obtain easy reproducible and accurate alignment of the picture tube and the deflection unit, the cone of the picture tube has a moulded indexing ridge to centre the deflection unit housing.

The deflection unit is brought into correct position by alignment of the protrusion on the housing with the location mark on the cone of the tube.

The unit must be pressed against the cone, so that the housing is indexed by the moulded ridge on the cone. The unit is then fixed by tightening the screw in the clamping ring at the rear. The screw should be tightened with a torque of 1,2 to 1,4 Nm.

ELECTRICAL DATA

Line coils, parallel connected

inductance

1,14 mH ± 4%

resistance at 25 °C

0,9 Ω ± 10%

Line deflection current, edge to edge at 25 kV

6,2 A p-p

Field coils, series connected

inductance

3,9 mH ± 10%

resistance at 25 °C

3,36 Ω ± 7%

Field deflection current, edge to edge at 25 kV

3,4 A p-p

4-pole coils, sensitivity

	A51-500X	A47-500X
for line	± max. 23 mm/A	21 mm/A
for field	± max. 16 mm/A	15 mm/A
resistance (series connected)	1,4 Ω	

for line

± max. 23 mm/A

21 mm/A

for field

± max. 16 mm/A

15 mm/A

resistance (series connected)

1,4 Ω

Maximum operating temperature

95 °C

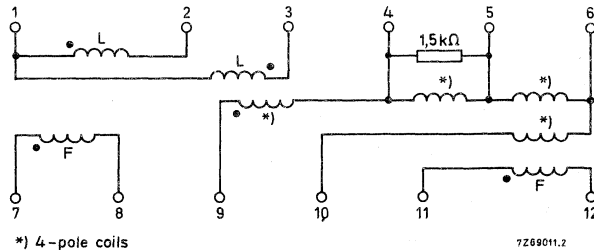

Fig. 2. Connection diagram.

L = Line

F = Field

Fig. 3. Terminal location.

The pin numbering corresponds to that in Fig. 2.

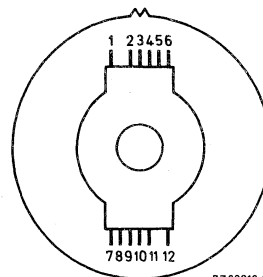

BEAM CORRECTIONS

With the deflection unit AT1085 and the multipole unit AT1081 mounted on the tube A51-500X or A47-500X the following corrections may be required:

Maximum required horizontal displacement of the electron beams with respect to the phosphor stripes by the purifying magnet of the AT1081 ¹⁾	A51-500X	A47-500X
	45 μ m	45 μ m

Static convergence deviations must be corrected by the adjustable four-pole and six-pole fields of the AT1081 centred around the tube axis.

Maximum required compensation for static convergence		
4-pole device: red opposite to blue (in any direction)	5 mm	4,5 mm
6-pole device: red and blue to green (in any direction)	2,5 mm	2,3 mm

North-South raster shape correction circuitry is not required.

To obtain a symmetrical shape for the horizontal lines at the upper part and the lower part of the screen, the unit AT1081 comprises an additional two-pole correction magnet giving a displacement of the beam in the centre of the screen in vertical direction of maximum

4 mm	3,5 mm
------	--------

Maximum centring error in any direction after colour-purity, static convergence, and horizontal centre line correction

4 mm	4 mm
------	------

With respect to dynamic convergence, the display system, consisting of picture tube A51-500X or A47-500X and deflection unit AT1085 is inherently self converging. However, a small fixed line parabola correction of 1,3 mm for tube A51-500X and of 2,6 mm for tube A47-500X, is required and also small corrections should be made to compensate for tolerances and asymmetries in the tube and deflection unit combination.

For this purpose two types of dynamic magnetic four-pole fields can be used.

One is generated by additional windings on the yoke ring of the deflection unit energized by adjustable sawtooth currents synchronized with scanning.

The other type is generated by sawtooth and parabolic currents which are synchronized with scanning and flow through the deflection coils.

Compensation to be provided by these corrections:

- horizontal red-to-blue distance at the end of the horizontal axis (line symmetry)	2)	0 \pm 1,5 mm
- horizontal red-to-blue distance at the ends of the vertical axis (field symmetry)	3)	\pm 1,5 mm
- vertical red-to-blue distance at the ends of the horizontal axis in opposite directions (line balance)	4)	0 \pm 1,0 mm
- vertical red-to-blue distance at the ends of the horizontal axis in equal directions (line balance parabola)	5)	0 \pm 0,5 mm
- vertical red-to-blue distance at the top of the vertical axis (field balance top)	6)	0 \pm 1 mm
- vertical red-to-blue distance at the bottom of the vertical axis (field balance bottom)	7)	0 \pm 1 mm

Notes see next page.

Notes

- 1) Purity adjustment in vertical direction is not required.
- 2) This correction is made by feeding a sawtooth current of line frequency through the additional four-pole windings on the deflection unit.
- 3) This correction is made by feeding a rectified sawtooth current of field frequency through the additional four-pole windings on the deflection unit.
- 4) This correction is made by unbalancing the line deflection coils.
- 5) This correction is made by feeding a parabolic current of line frequency through the line deflection coils.
- 6) This correction is made by unbalancing the field deflection coils during the first half of the field scan.
- 7) This correction is made by unbalancing the field deflection coils during the second half of the field scan.

Application information available on request.



LINE OUTPUT TRANSFORMER

QUICK REFERENCE DATA		
5th harmonic tuned		
I_{EHT}	0,05	1,5 mA
E.H.T. *)	25	22,5 kV
R_{iEHT}	1,7	M Ω
Supply voltage (V_B)	185	183 V
current (I_B)	480	650 mA
I_{p-p} deflection	6,1	5,9 A

RZ 720915-07-01

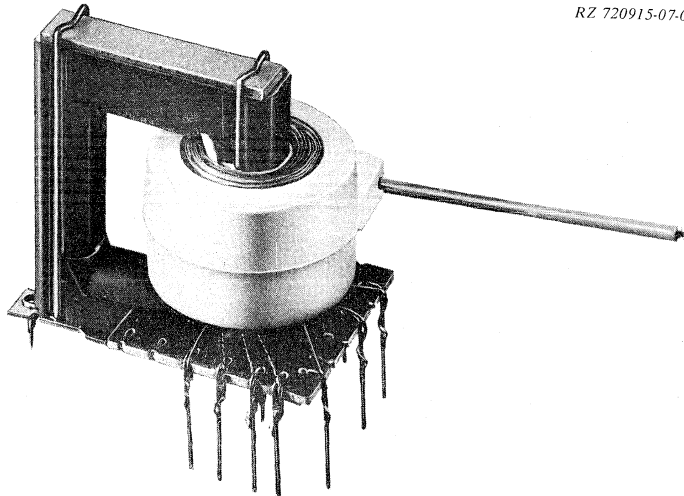

APPLICATION

This transformer has been designed to provide the required scanning amplitude for the 110° colour picture tube A66-140X in television receivers presenting 625 lines at 50 fields per second (CCIR) or 525 lines at 60 fields per second (USA).

It is intended for use in conjunction with:

- deflection unit AT1062/01
- linearity control unit AT4042/06
- line output transistor BU208
- E.H.T. tripler module BG1895-641.

*) after tripler module

DESCRIPTION

The magnetic circuit of the transformer comprises a ferroxcube U- and a ferroxcube I-core pressed together by means of brackets. The primary windings, the secondary windings and the E.H.T. winding are situated on one leg of the core. The E.H.T. winding is encapsulated in flame retarding polyester *).

The transformer has been provided with four mounting pins and two threaded holes for mounting.

External circuit connection is made to connecting pins, positioned as indicated in Fig. 1, enabling the unit to be soldered directly into a printed wiring board (Fig. 2).

MECHANICAL DATA

Dimensions (mm) and terminals

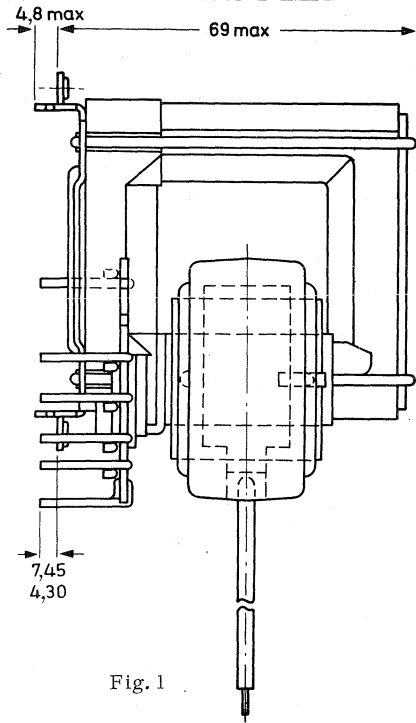
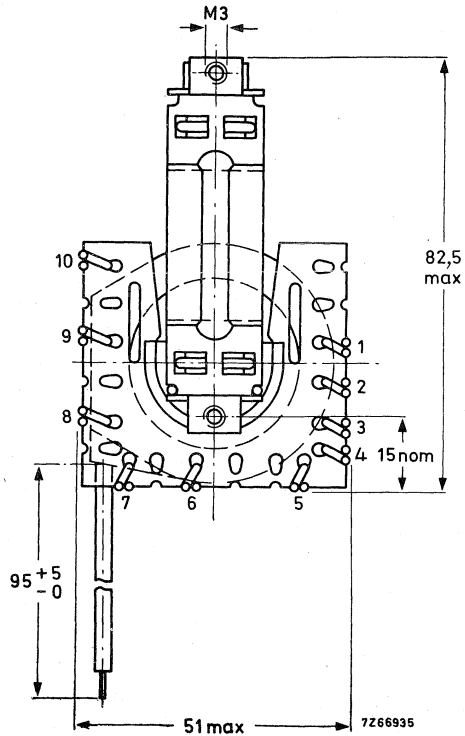

Fig. 1

Weight

240 g approximately



*) Complying with the self-extinguishing and non-dripping properties of the American Underwriters' Laboratories' rating mentioned in UL94SE-1.

Distances

The following minimum distances between the transformer and neighbouring conductive flat surfaces (in proportion to their sharpness protruding parts must have a greater distance) must be maintained:

From the E.H.T. winding, radially 15 mm
axially 10 mm

From the E.H.T. lead 15 mm

The transformer and the leads and components carrying high tension pulses should be kept free from metal particles, solder drops etc.

ELECTRICAL DATA (see circuit diagram)

EHT _{supply}	I_{EHT}	mA	0,05	1,5
	EHT	kV	25	22,5
	R_{iEHT}	M Ω	1,7	
Power supply	V_B	V	185	183
	V'_B (pin 8)	V	172	165
	I_B	mA	480	650
Output transistor	V_{CEM}	V	1200	1165
	$+I_{CM}$	A	3,9	3,9
	$-I_{CM}$	A	2,9	2,7
Deflection	$I_{defl. p-p}$ flyback ratio (zero line)	A	6,1	5,9
		%	17,7	
	Overscan variation	%	0	1,0
Low voltage supply (pin 6)	V	V	28,7	27,5
	$I_{dc max.}$	A	1,2	

For auxiliary windings see circuit diagram (pins 1, 2, 3, 4)

DIODE-SPLIT LINE OUTPUT TRANSFORMER

QUICK REFERENCE DATA	
I_{eht}	max. 1,5 mA
E. H. T.	25 kV
$R_i(eht)$	2 M Ω
I_{p-p} deflection (incl. 6% overscan)	6,5 A
Load inductance (of line deflection coils)	1,12 mH
Supply voltage (V_B^1)	148 V
current ($I_{average}$) at $I_{eht} = 1,5$ mA	785 mA
Voltages of auxiliary windings	-335 V p, -160 V p, +160 V p, +335 V p, picture tube heater voltage

APPLICATION

This transformer has been designed to provide the required scanning amplitude for 20 AX 110° colour picture tubes with a neck diameter of 36,5 mm in transistor equipped television receivers presenting 625 lines at 50 fields per second (CCIR) or 525 lines at 60 fields per second (USA).

It is intended for use in conjunction with:

- deflection unit AT1080, AT1083/01 or AT1085;
- linearity control unit AT4042/33;
- line output transistor BU208A;
- a screened e.h.t. cable with a length of 1 m (available under catalogue number 3122 137 58250),

as shown in the circuit diagram of Fig. 3.

DESCRIPTION

The magnetic circuit of the transformer comprises 2 Ferroxcube U-cores, screwed together. The primary winding is situated on one leg of the core, the secondary on the other leg. The windings are impregnated in flame retarding polyester, meeting the self-extinguishing requirements of IEC65, para. 14.4 and UL492, para. 280-SE1. The transformer is provided with 2 M3 screw-studs for mounting ¹⁾. External circuit connection is made to connecting pins, positioned as indicated in Fig. 1 enabling the unit to be soldered directly into a printed-wiring board (Fig. 2).

¹⁾ For mounting on the printed-wiring board a washer of 20 mm in diameter has to be used. Tightening torque on printed-wiring board: 500 + 100 mNm.

MECHANICAL DATA

Dimensions (mm) and terminals

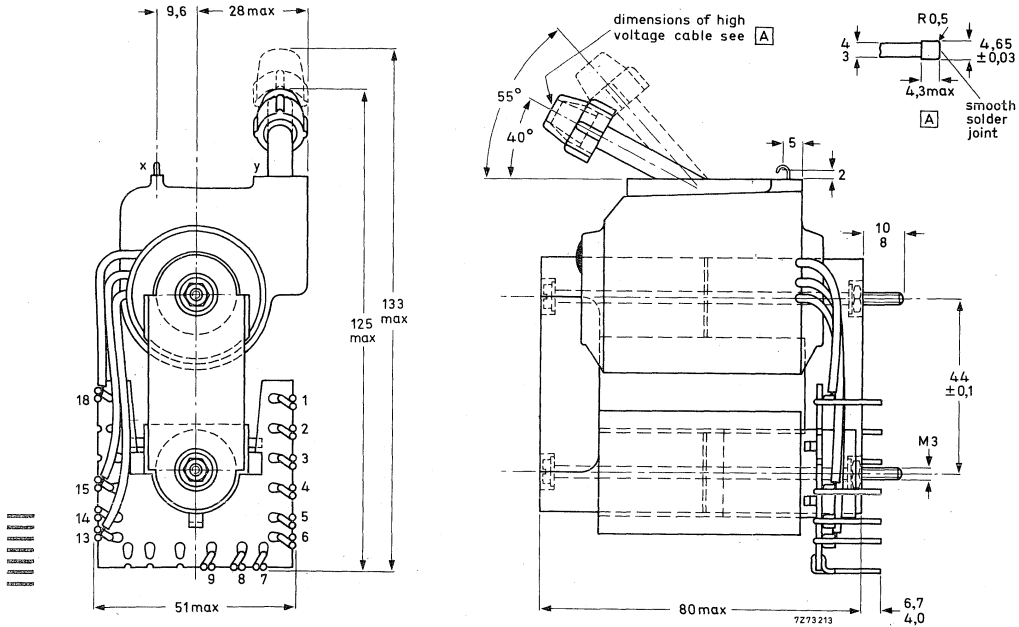

Fig. 1

Weight 500 g approximately

Solderability in accordance with IEC68, Test T

MOUNTING

The transformer may be mounted on either a printed-wiring board or, under certain conditions, on a metal chassis. Two securing studs (M3) are provided. The fit of the connecting and the mounting pins in a printed-wiring grid with a pitch of 2,54 mm is illustrated in Fig. 2.

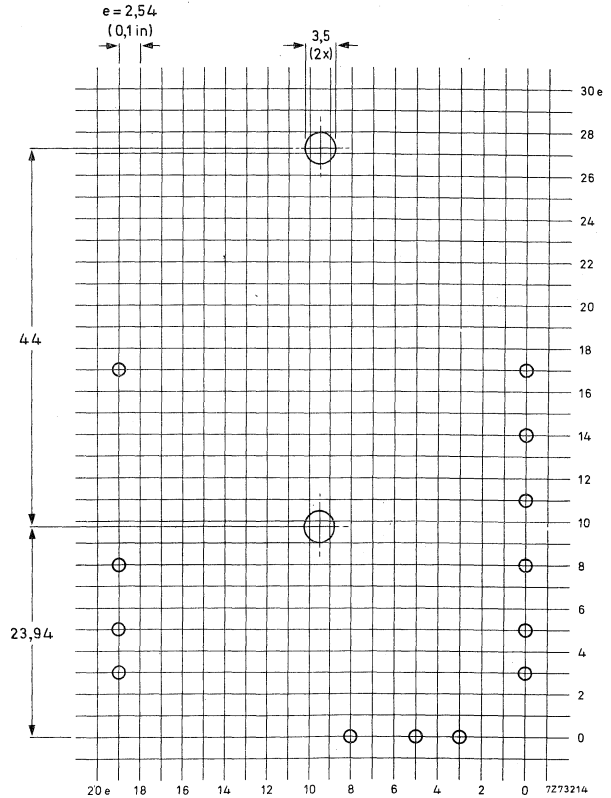

Fig. 2
Hole pattern for mounting on a printed-wiring board (solder side). Grid hole diameter $1,3 \pm 0,1$ mm.

Whether the transformer is board or chassis mounted, the core must be earthed.

Temperature

The operating temperature of the e.h.t. coil should not exceed $+85^{\circ}\text{C}$ under worst conditions, i.e. taking into account:

- over-voltage on the coils;
- low atmospheric pressure (at high altitudes) implying bad cooling by convection;
- high ambient temperature (up to 45°C).

To satisfy this requirement it may be necessary to provide an ample cool air flow around the transformer.

Distances

The following minimum distances between the transformer and neighbouring conductive flat surfaces must be maintained (it should be noticed that edges of conductive parts must have a greater distance) :

From the e.h.t. coil, radially 10 mm
axially 10 mm

The transformer, and the leads and components carrying high voltage pulses, should be kept free from metal particles, solder drops etc.

ELECTRICAL DATA (measured in circuit of Fig. 3)

E.H.T. supply	I_{eht}	mA	0,05	1,5
	e.h.t.	kV	25,2	22,0
	$R_{i(eht)}$	MΩ	2,0	
Power supply	V_B	V	168	
	$V_{B'}$	V	148	140
	$I_{average}$	mA	580	785
Output transistor	V_{CEM}	V	1190	1120
	$+I_{CM}$	A	3,9	4,0
Deflection	Load inductance (of line deflection)	mH	1,12	
	I_{p-p} flyback (incl. 6% overscan)	A	.6,5	6,2
	$t_{flyback}$	μs	11,5	
	Overscan	%	6	
	Variation	%	2	
V_{focus}		kV	6,15	5,45
Auxiliary windings :				
picture tube heater voltage	V_{1-2}	V	6,62	r. m. s. 6,18
voltages at pin 3	V_3	V	-335 p (+40 V d.c.)	
pin 4	V_4	V	-160 p (+14 V d.c.)	
pin 6	V_6	V	+160 p	
pin 7	V_7	V	+335 p	
pin 8	V_8	V	+235	d.c. +230 V

1) Video supply.

APPLICATION CIRCUIT

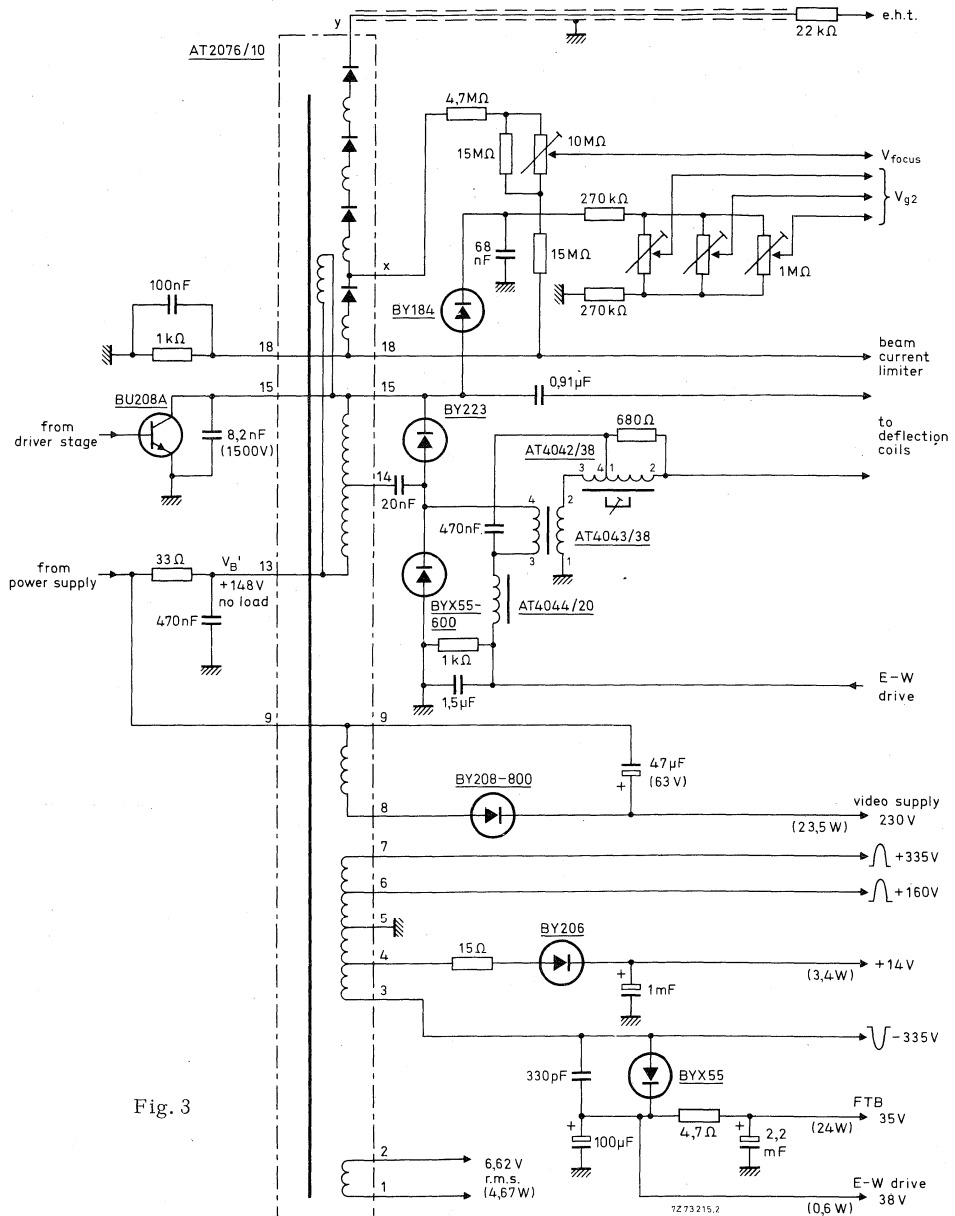

Fig. 3

7273215.2

LINE OUTPUT TRANSFORMER

QUICK REFERENCE DATA	
I_{eht}	max. 1,5 mA
E. H. T.	8,4 kV
$R_{i(eht)}$	2 M Ω
I_{p-p} deflection (incl. 6% overscan)	6,5 A
Load inductance (of line deflection)	1,12 mH
Supply voltage (V_B)	148 V
current (I_B) at $I_{eht} = 1,5$ mA	780 mA
Peak voltages of auxiliary windings	-320 V, -155 V, +155 V, +320 V, picture-tube heater voltage

APPLICATION

This transformer has been designed to provide the required scanning amplitude for 20AX 110⁰ colour picture tubes with a neck diameter of 36,5 mm in transistor equipped television receivers presenting 625 lines at 50 fields per second (CCIR) or 525 lines at 60 fields per second (USA).

It is intended for use in conjunction with:

- deflection unit AT1080, AT1083/01 or AT1085;
 - linearity control unit AT4042/38
 - line output transistor BU208A
 - e. h. t. rectifier/multiplier device BG1895 641 444
- according to circuit diagram of Fig. 3.



DESCRIPTION

The magnetic circuit of the transformer comprises Ferroxcube U and I-cores clamped together with brackets. The primary windings, the secondary windings and the e. h. t. winding are situated on one leg of the core. The windings are impregnated in flame retardant polyester, meeting the self-extinguishing requirements of IEC 65, para. 14.4 and UL492, para. 280-SE1. The transformer is provided with four pins and two threaded holes for mounting. External circuit connection is made to connecting pins, positioned as indicated in Fig. 1, enabling the unit to be soldered directly into a printed-wiring board (Fig. 2).

MECHANICAL DATA

Dimensions in mm

Outlines

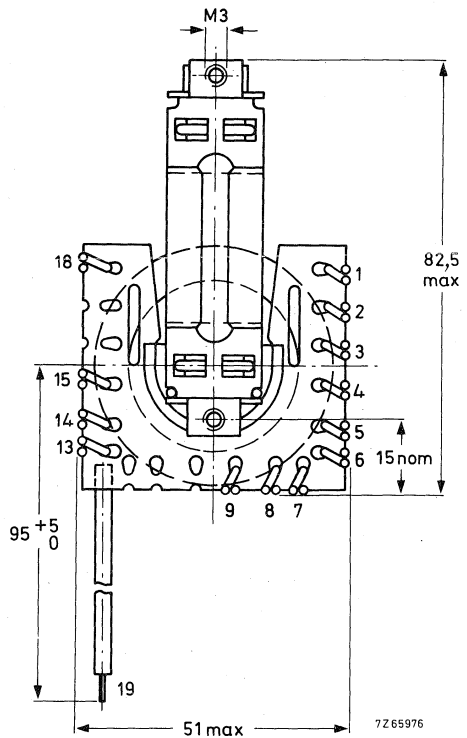
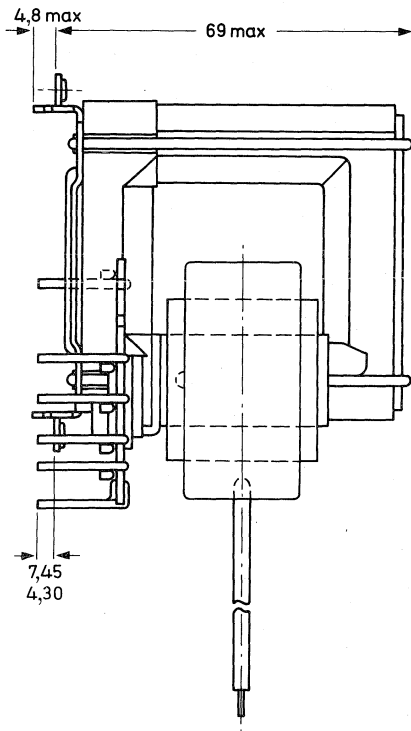

Fig. 1

Mass

240 g approximately

MOUNTING

The transformer may be mounted on either a printed-wiring board or, under certain conditions, on a metal chassis. It may be secured with M3 screws.

For mounting on a printed-wiring board the fit of the connecting and the mounting pins in a printed-wiring grid with a pitch of 2,54 mm is illustrated in Fig. 2.

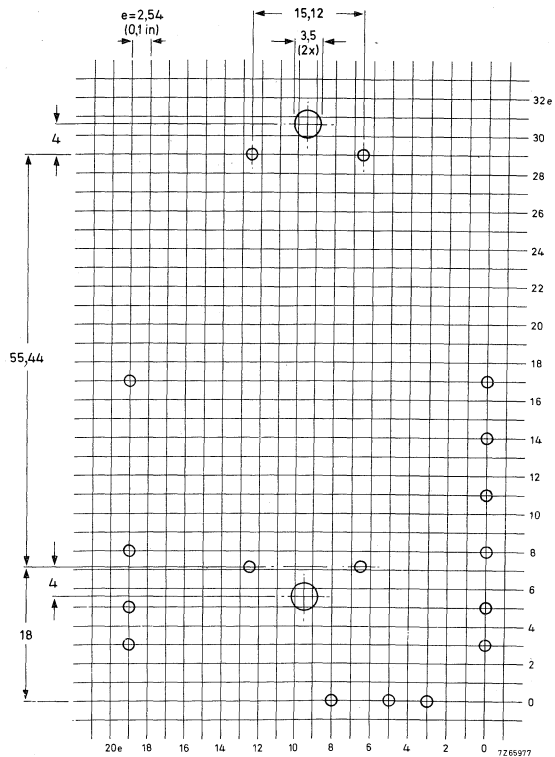

Fig. 2 Hole pattern for mounting on a printed-wiring board (solder side).
Grid hole diameter
 $1,3 \pm 0,1$ mm

Whether the transformer is board or chassis mounted, the core must be earthed.

Temperature

The operating temperature of the core and the coils should not exceed 105 °C, under worst conditions, i. e. taking into account:

- overvoltage on the windings
- low atmospheric pressure (at high altitudes) implying bad cooling by convection
- high ambient temperature (up to 45 °C).

To satisfy this requirement it may be desired to provide ample cool air circulation around the transformer.

Distances

The following minimum distances between the transformer and neighbouring conductive flat surfaces must be maintained (it should be noticed that edges of conductive parts must have a greater distance):

- a. From the e.h.t. winding, radially 15 mm
axially 10 mm
- b. From the e.h.t. lead 15 mm

The transformer, and the leads and components carrying high voltage pulses should be kept free from metal particles, solder drops, etc.

→ ELECTRICAL DATA (typical values)

E.H.T. supply	I_{eht}	mA	0,05	1,5
	e. h. t.	kV	24,9	22,0
	$R_{\text{i(eht)}}$	M Ω	2	
Power supply	V_{B}	V	167	166
	$V_{\text{B}'}$	V	148	140
	I_{average}	mA	570	780
Output transistor	V_{CEM}	V	1200	1120
	$+I_{\text{CM}}$	A	4,0	4,0
	$I_{\text{p-p}}$	A	6,5	6,2
Deflection	flyback ratio (average)	μs	11,6	
	Overscan	%	6	
	Variation	%	1,5	
Focus voltage		kV	8,2	7,5
Auxiliary windings:				
picture-tube heater voltage	V_{1-2}	V	8,2	7,6
peak voltages at pin 3	V_3	V	-320	
pin 4	V_4	V	-155	
pin 6	V_6	V	+155	
pin 7	V_7	V	+320	
pin 8	V_8	V	-520	

Tuning frequencies $\alpha = 43,3 \text{ kHz}$

$\gamma = 206 \text{ kHz}$ (for additional information see Product Note No. 63, titled "Tuning of a transistor-driven line output stage in the TV receiver").

APPLICATION CIRCUIT

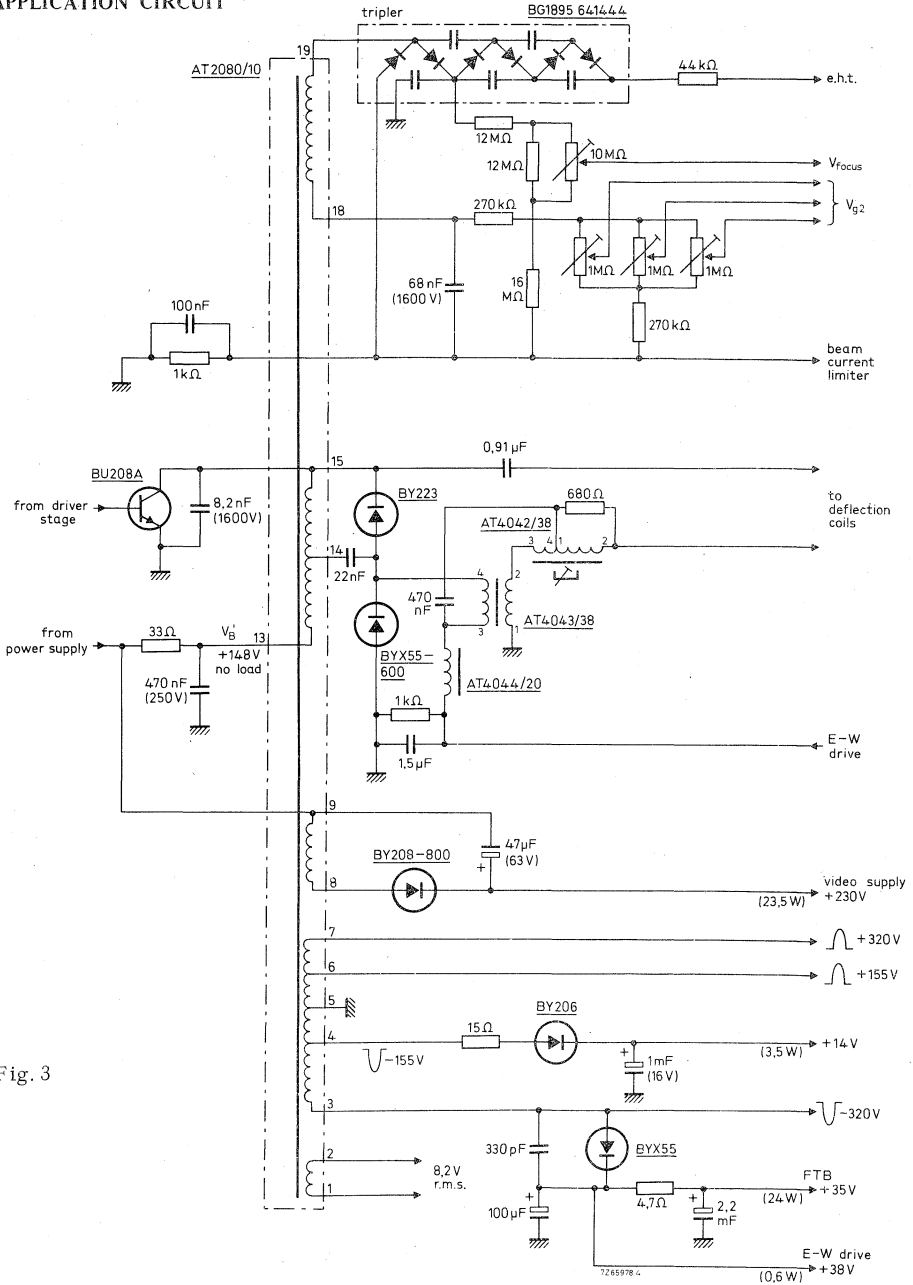
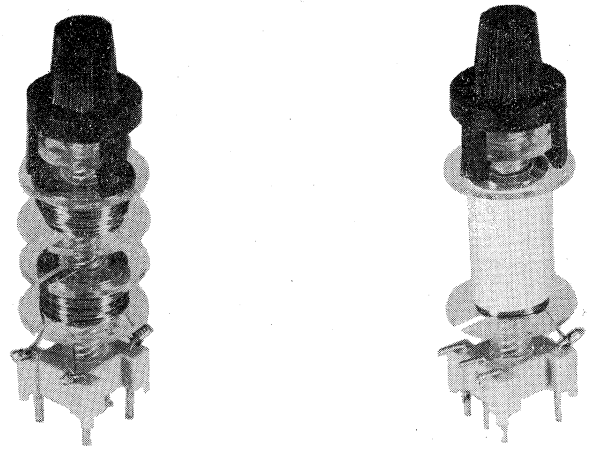

Fig. 3

CONVERGENCE ADJUSTERS



APPLICATION

These adjusters are intended for use in conjunction with the convergence unit AT4046/.. for convergence adjustment.

MECHANICAL DATA

The convergence adjusters are provided with pins for mounting on printed-wiringboards with holes of $\phi 1.3 + 0,1$ mm. They have a knob at the top for adjustment.

Dimensions in mm

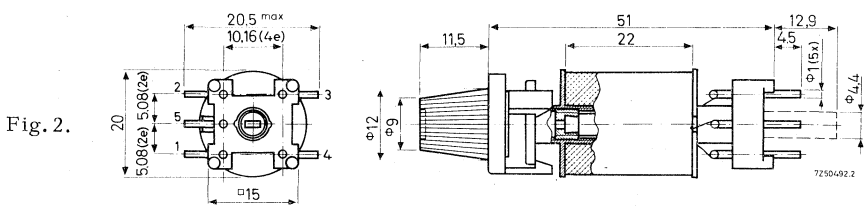
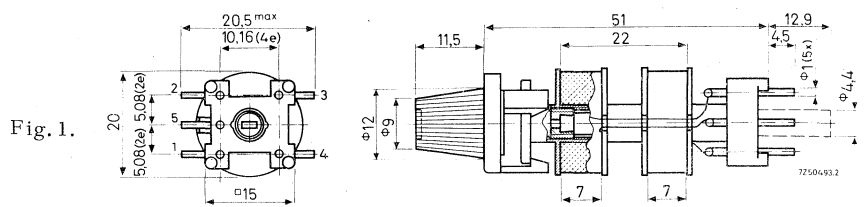

ELECTRICAL DATA (typical values)

type number	circuit diagram	Fig.	terminals	L- range or L (mH)	d. c. resistance (Ω)	catalogue number
AT4040/35 [*])	A	1	1-5	0.17-0.07	0.48	3122 108 74390
			2-5	0.07-0.17	0.48	
			3-4	0.05	0.18	
AT4040/44	B	2	3-4	15.6-3.0	11.5	3122 138 22870
AT4040/49	C	1	3-4	1.06-0.33	2.4	3122 107 30030
			1-2	0.33-1.06	2.4	
AT4040/53	B	2	3-4	3.72-0.63	3.65	3122 107 30060
AT4040/57	C	1	3-4	0.32-0.10	0.66	3122 107 30090
			1-2	0.10-0.32		
AT4040/56	E	1	4-5	0.024-0.006	0.11	3122 107 30080
			1-4	0.006-0.024	0.11	
			2-3	0.030-0.011	0.17	
AT4040/58	C	1	3-4	8.15-2.5	20.7	3122 107 30100
			1-2	2.5-8.15		
AT4040/61	B	2	3-4	33.5-7.2	23.1	3122 107 30130
AT4040/63	C	1	3-4	0.44-0.11	1.35	3122 107 30480
				0.11-0.44	1.35	
AT4040/89	C	1	1-2	4.5-12	25	3122 138 25770
			3-4	4.5-12	25	
AT4040/92 [*])	D	1	3-4	0.07-0.22	0.65	3122 138 25780
			1-2	0.07-0.22	0.78	
			1-4	0.04	0.58	
AT4040/93	C	1	1-2	0.21-0.58	1.05	3122 138 25790
			3-4	0.21-0.58	1.05	

At a frequency of 15 kHz the current through the convergence adjustment coils has to be such that the formula $I_{\text{rms}}^2 \cdot R_{\text{dc}} \leq 0.3 \text{ W}$ remains in force.

^{*}) Six mounting pins, pin 5 is marked by a colour dot.

Circuit diagrams

A

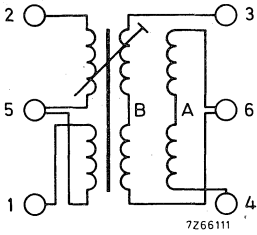

B

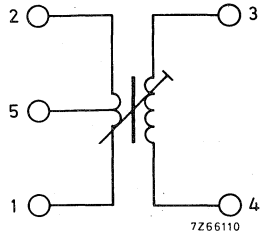

C

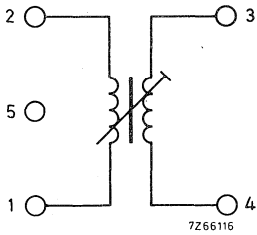

D

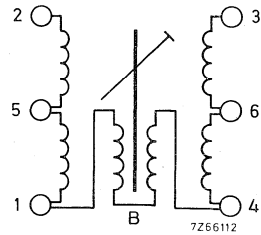

E

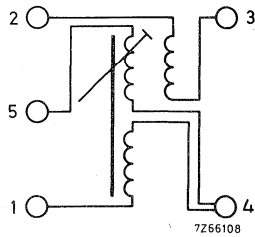

CORRECTION COILS

RZ 30369-13

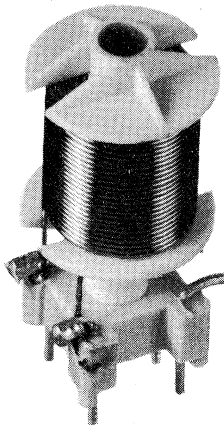

V 27807

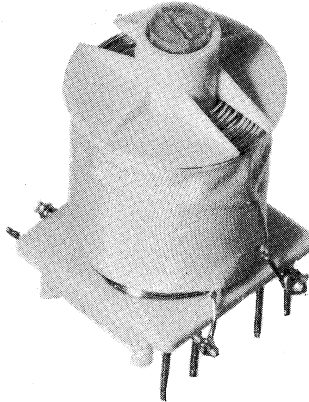

RZ 30369-2

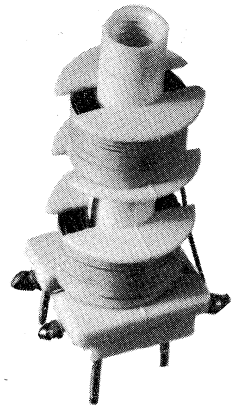

V 25546

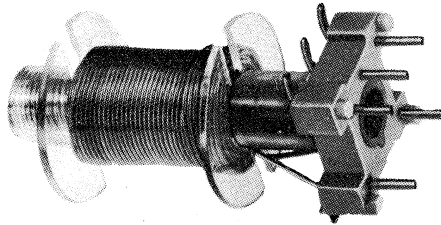

APPLICATION

The correction coils are mainly intended for use with the transducers AT4041/.. and the deflection units AT1027/.., AT1029/.., AT1060/.. and AT1062.. for raster correction. The AT4040/50 is for deflection units with parallel-connected frame coils, the AT4040/55 for series-connected frame coils.

The AT4040/31 is also intended for use as the balancing coil between the combined EHT and semi-scan transformer AT2100/04 and the semi-scan transformer AT2101/02.

The AT4040/38 has also an auxiliary winding for convergence.

MECHANICAL DATA

The coils are provided with pins for mounting on printed-wiring boards with holes of $\phi 1,3 + 0,1$ mm. They can be adjusted at the top by means of a trimming key.

Dimensions in mm

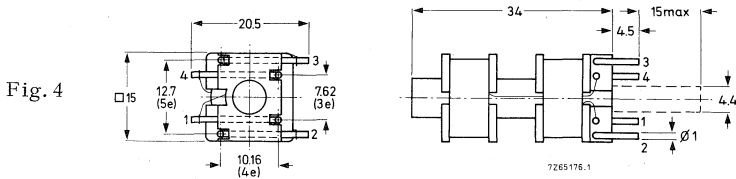
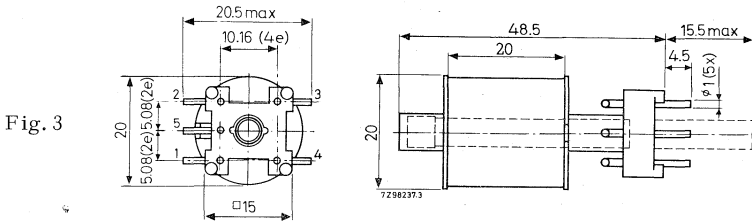
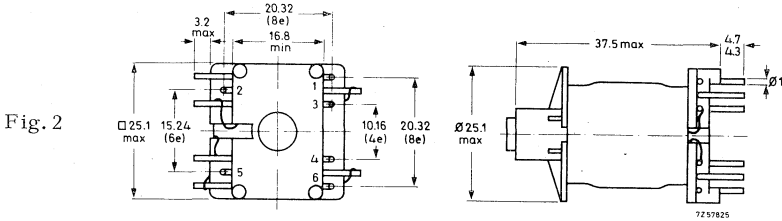
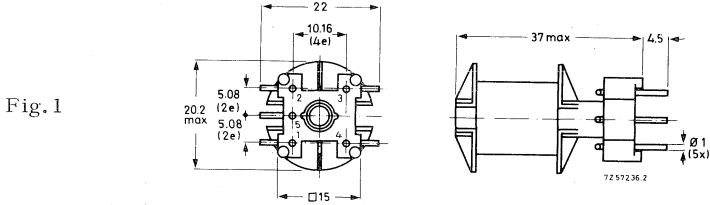

ELECTRICAL DATA (typical values)

type number	circuit diagram	Fig.	terminals	L- range or L (mH)	d. c resistance (Ω)	catalogue number
AT4040/31 bridge coil	A	1	3-4	1.1	0.82	3122 108 74400
AT4040/32 phase adjuster	B	2	3-4	1.6-4	1.18	3122 108 74340
AT4040/34 2nd harm/anti- S	A	1	3-4	0.03-0.1	0.18	3122 108 74410
AT4040/36 balancing coil	A	3	3-4	0.08-0.56	0.22	3122 138 21090
AT4040/38 2nd harm	C	1	1-2 3-4	1.17 0.033-0.13	6.5 0.33	3122 138 26320
AT4040/50 amplitude adjuster	A	3	3-4	0.76-3.71	1.1	3122 107 31210
AT4040/55 amplitude adjuster	A	3	3-4	2.46-11.5	4.1	3122 107 31220
AT4040/85 balancing coil	D	4	1-2 3-4	0.03-0.1 0.03-0.1	0.23 0.23	3122 138 25750
AT4040/87 phase adjuster	E	2	3-4	1.85 \pm 20%	2	3122 138 25760

Circuit diagrams

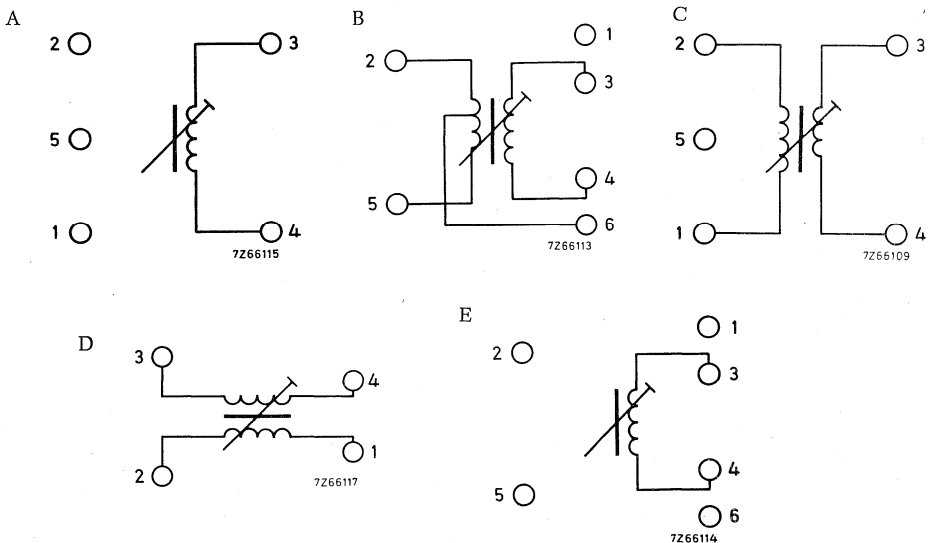

TRANSDUCTOR

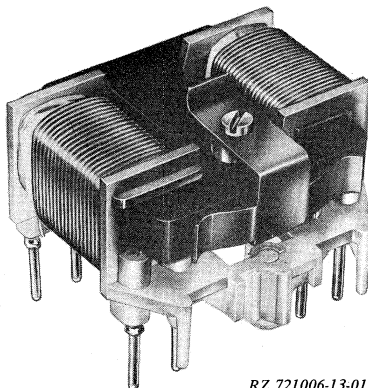

RZ 721006-13-01

The transductor has been developed for use in combination with the deflection unit AT1062/01 ^{*}), and the adjusters AT4040/87 and AT 4040/38 for passive north-south raster correction in 110° colour television tubes. A coil AT4040/31 is used as a series choke for a passive N-S pincushion correction.

For adjusting the horizontal lines on the picture tube screen (Fig.1) the transductor is provided with a rod-magnet which can be turned by a screw driver (minimum torque 0,4 Ncm, maximum torque 2 Ncm).

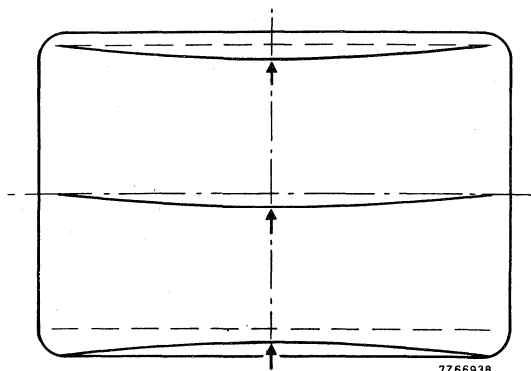

Fig.1

7266938

^{*}) Frame coils series connected.

MECHANICAL DATA

Dimensions (mm) and connections

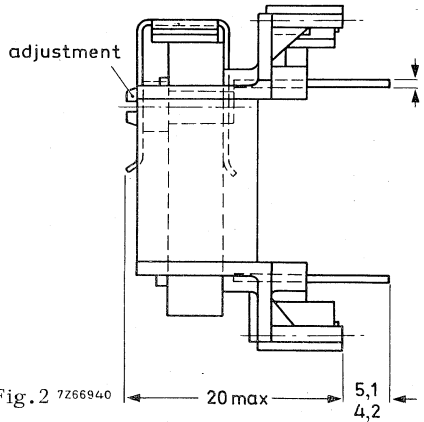
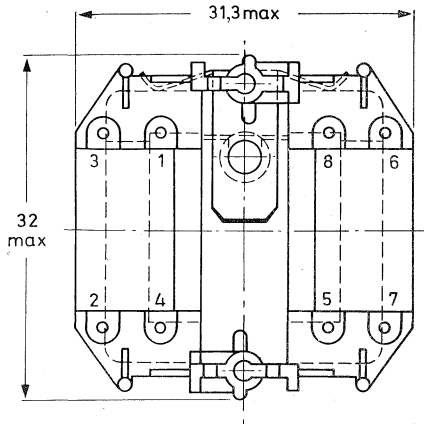

Fig. 2 7Z66940

Weight approximately 20 g

Mounting

The transducer is provided with 8 pins for mounting on a printed-wiring board (Fig.3).

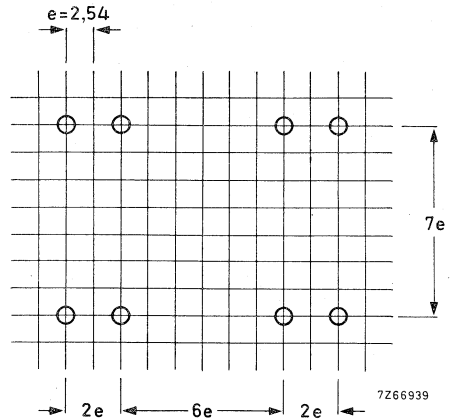

Fig. 3 Hole pattern for mounting on a printed-wiring board.
Hole diameter $1.3 + 0,1$ mm.

The ambient temperature should not exceed 65°C . By mounting the polycarbonate capacitor and the NTC thermistor (as given in the circuit diagram) close to the transducer, a phase-drift can be prevented.

ELECTRICAL DATA

Transductor measured without rod magnet. With rod magnet V_{R1} and V_{R2} can be changed with minimum $\pm 0,5$ V.

	oscillogram	voltmeter adjustment (V r.m.s.)		values
	Fig.	M2	M4	
I_{max}	5	16	20	880 mA $\pm 10/-15\%$
V_{R1}	6	16	20	8,8 V $\pm 9\%$
V_{R2}	6	16	20	8,8 V $\pm 9\%$
$V_{R1}-V_{R2}$	6	16	20	0 to max. 0,6 V

Measuring circuit

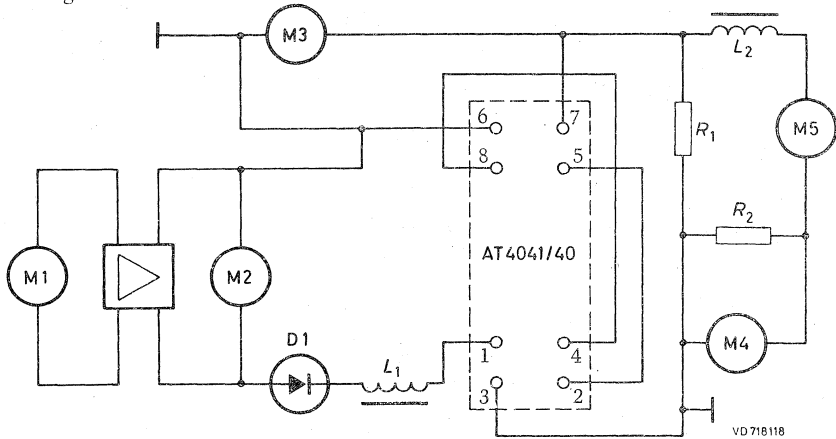

Fig.4 M1 = l.f.generator 3 kHz L1 = 0,7 mH
 M2 = tube voltmeter L2 = min. 20 mH
 M3 = oscilloscope D1 = BA148
 M4 = tube voltmeter R1 = 10 Ω , 5 W
 M5 = l.f.generator 50 Hz R2 = 47 Ω , 40 W

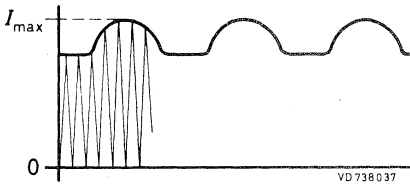

Fig.5

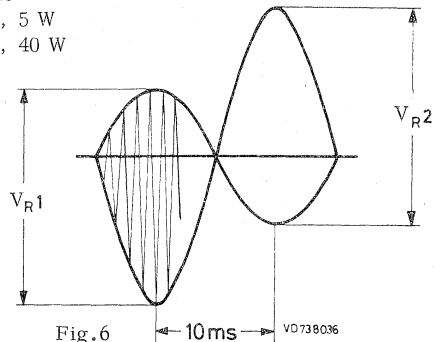

Fig.6

Test voltage 2000 V d.c.

CIRCUIT DIAGRAM FOR PASSIVE RASTER CORRECTION

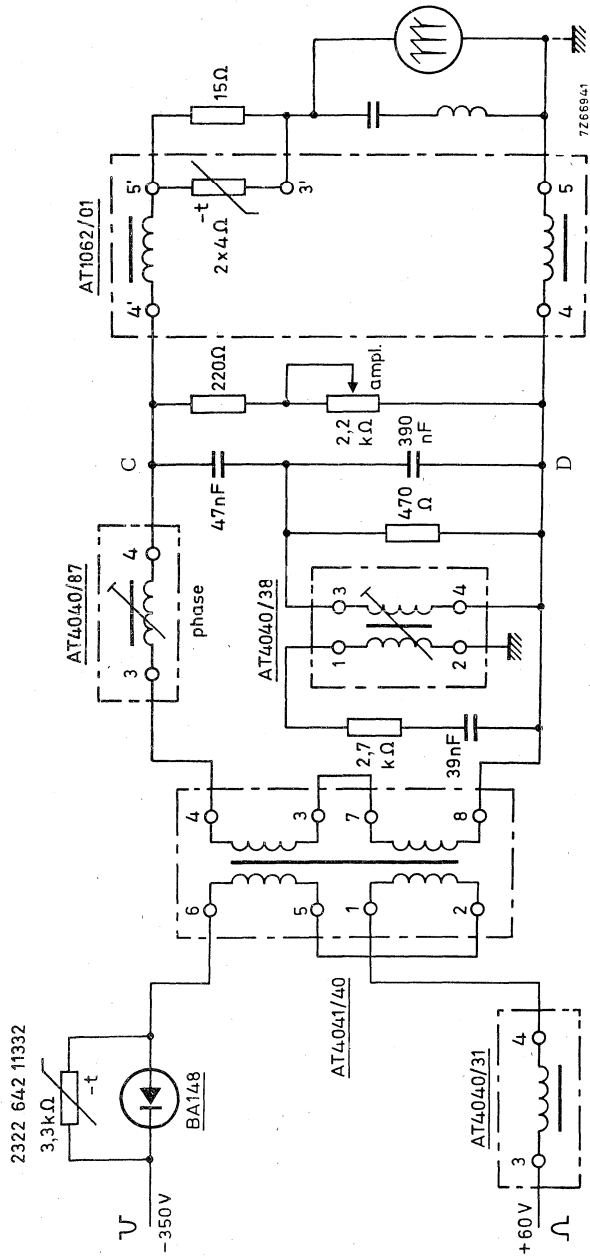

Fig. 7 Input voltage typ. 400 V p-p
Input current typ. 800 mA

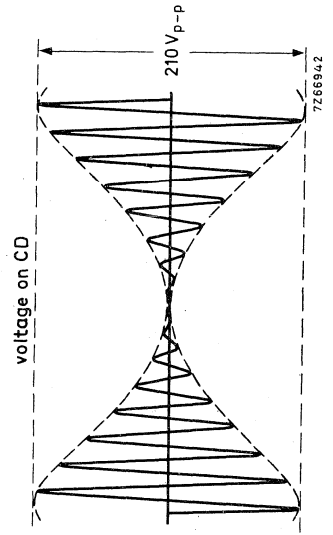
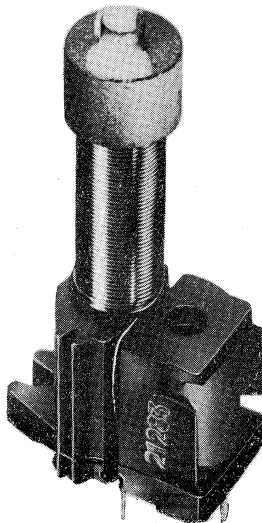

Fig. 8

ADJUSTABLE LINEARITY CONTROL UNIT

A 55126-1A



APPLICATION

This unit has been designed for use in colour TV sets equipped with a 110° deflection angle colour picture tube, to adjust the linearity of line deflection. It can be used in combination with the unit AT 1062/01 if parallel connected line coils are used.

CONSTRUCTION

The unit consists of a coil, mounted on a ferroxcube rod, two ferroxcube magnets and one plastoferrite magnet. One magnet has the shape of a ring and is placed around the ferroxcube rod above the coils. One has the shape of a half ring and is placed around the ferroxcube rod under the coils. The third magnet is cylindrical; it is positioned to and clamped against the ferroxcube rod opposite the half ring magnet. It is provided with a square hole to facilitate turning to adjust the biasing field and, therefore, the linearity of the line deflection.

MECHANICAL DATA

Dimensions (mm)

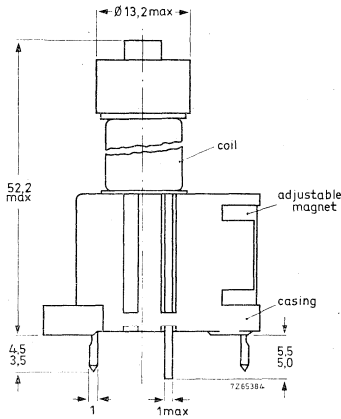
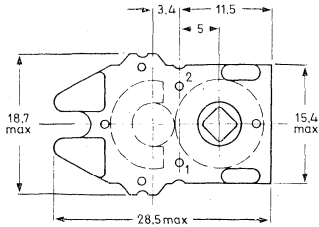

Fig. 1

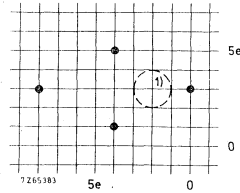

Fig. 2 Hole pattern for mounting on a printed-wiring board.
Hole diameter 1,3 + 0,1
e = 2,54

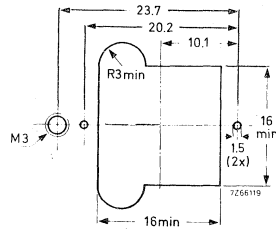
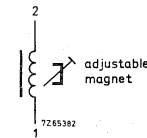

Fig. 3 Hole pattern for mounting on a chassis

ELECTRICAL DATA

When a saw-tooth current of a peak-to-peak value of 6A, frequency 15 625 Hz, fly-back ratio 18% (without S- correction) flows through the linearity control unit (coils connected in parallel, one connection point to earth), the correction voltage is adjustable between 15 and 25 V.

For connections see the relevant data sheets of line-deflection transformers.



circuit diagram

MOUNTING

The unit can be mounted either on printed-wiring boards by means of its two connection pins and two mounting pins, or on metal chassis by bending the two mounting pins and/or by means of a screw through an aperture in the casing (see Fig.3). To prevent distortion of the magnetic field, no iron part should approach the magnetic part nearer than 3 mm. The coils should be shunted with carbon resistors to damp ringing phenomena; the value of resistor depends on applied deflection transformer.

1) Hole only necessary for bottom adjustment.

ADJUSTABLE LINEARITY CONTROL UNIT

APPLICATION

This unit has been designed for use in colour TV sets equipped with a 110° deflection angle colour picture tube, to adjust the linearity of line deflection. It can be used in combination with the unit AT1080 if parallel connected line coils are used.

DESCRIPTION

The unit consists of a coil, mounted on a ferroxcube rod, two ferroxdure magnets and one plastoferrite magnet. One magnet has the shape of a ring and is placed around the ferroxcube rod above the coils. One has the shape of a half ring and is placed around the ferroxcube rod under the coils. The third magnet is cylindrical; it is positioned to and clamped against the ferroxcube rod opposite the half ring magnet. It is provided with a square hole to facilitate turning to adjust the biasing field and, therefore, the linearity of the line deflection.

MECHANICAL DATA

Dimensions (mm)

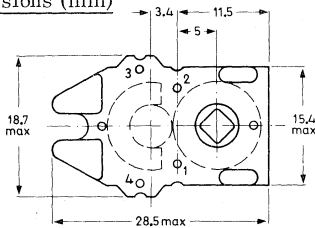

Fig. 1

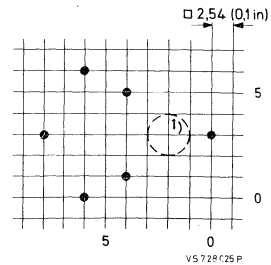

Fig. 2 Hole pattern for mounting on a printed-wiring board.
Hole diameter 1, 3 + 0, 1

1) Hole only necessary for bottom adjustment.

ELECTRICAL DATA

The correction voltage is pre-adjusted to 30 V at a saw tooth current of 6,4 A peak-to-peak, frequency 15625 Hz, fly-back ratio 18 % (without S-correction), flowing through winding 1-2. The voltage between pins 2 and 3 (pins 1 and 4 interconnected) is then 37 V.

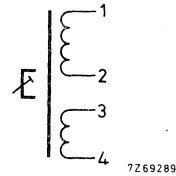

Fig. 3 Circuit diagram

MOUNTING

The unit can be mounted either on printed-wiring boards by means of its four connection pins and two mounting pins, or on metal chassis by bending the two mounting pins and/or by means of a screw through an aperture in the casing (see Fig. 3). To prevent distortion of the magnetic field, no iron part should approach the magnetic parts nearer than 3 mm. The coils should be shunted with a carbon resistor to damp ringing phenomena; the value of resistor depends on applied deflection transformer (typical value 820 Ω with transformer AT2080/10).

*) Pins 2 and 3 should be interconnected on the printed-wiring board.

ADJUSTABLE LINEARITY CONTROL UNIT

APPLICATION

This unit has been designed for use in colour TV sets equipped with a 110° deflection angle colour picture tube, to adjust the linearity of line deflection. It can be used in combination with the deflection units AT1080, AT1083/01 and AT1085.

DESCRIPTION

The unit consists of a coil, mounted on a Ferroxcube rod, and three Ferroxidure magnets. Two ring-shaped magnets are placed around the Ferroxcube rod, one at the top and one at the bottom. The third magnet is positioned against the Ferroxcube rod opposite the bottom magnet and clamped. It is provided with a square hole to facilitate adjustment of the biasing field and, therefore, the linearity of the line deflection.

MECHANICAL DATA

Dimensions (mm)

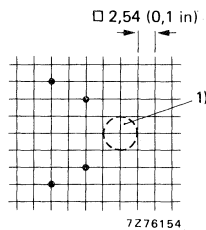
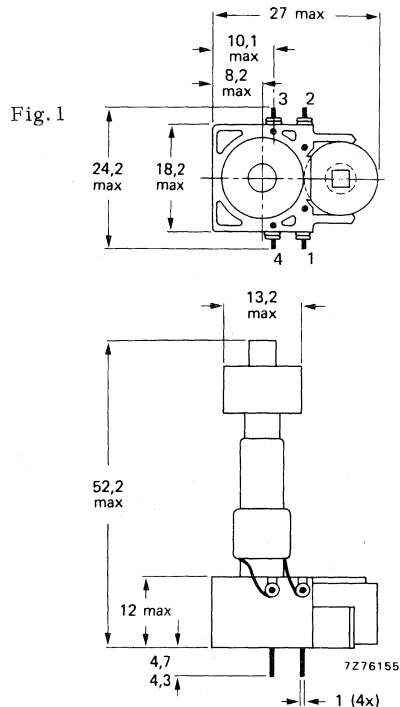

Fig. 2 Hole pattern for mounting on a printed-wiring board.
Hole diameter 1,3 + 0,1.



1) Hole (dia 5,1 mm min.) only necessary for bottom adjustment.

ELECTRICAL DATA

The correction voltage is pre-adjusted to $23,5 \text{ V} \pm 2,5\%$ at a saw-tooth current of $6,4 \text{ A}$ peak-to-peak, frequency $15\,625 \text{ Hz}$, flyback ratio 18% (without S-correction), flowing through winding 1 - 2. The voltage between pins 2 and 3 (pins 1 and 4 interconnected) is then $28,5 \pm 10\%$.

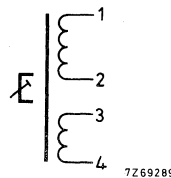

Fig. 3 Circuit diagram
*)

MOUNTING

The unit can be mounted on printed-wiring boards by means of its four connection pins (see Fig. 2). To prevent distortion of the magnetic field, no iron part should approach the magnetic parts nearer than 3 mm . The coils should be shunted with a carbon resistor to damp ringing phenomena; the value of resistor depends on applied deflection transformer (typical value $560 \, \Omega$ with transformer AT2076/10).

*) Pins 1 and 4 should be interconnected on the printed-wiring board.

FILTERING COIL

APPLICATION

The coil AT4043/15 has been designed for all-transistor colour television sets, to be used in the supply unit.

MECHANICAL DATA

The magnetic circuit of the coil comprises two iron U-cores.
The unit is provided with pins for mounting on a printed-wiring board.

Dimensions (mm)

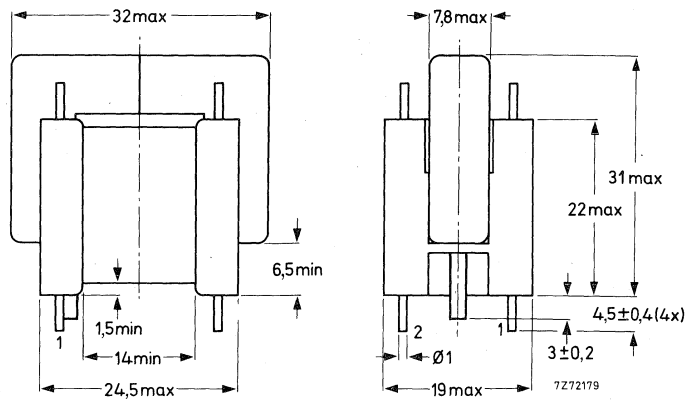

Fig.1

Mounting

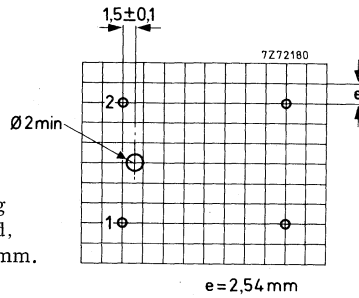
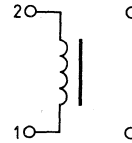

Fig. 2
Hole pattern for mounting
on a printed-wiring board,
hole diameter $1,3 + 0,1$ mm.

ELECTRICAL DATA

Inductance	$2,1 \text{ mH} \pm 15\%$
Resistance at $25 \text{ }^\circ\text{C}$	$0,27 \text{ } \Omega$
Maximum working temperature	$95 \text{ }^\circ\text{C}$



7265969.1

Fig. 3 Connection diagram



CLASS-D FILTER CHOKE

APPLICATION

The AT4043/35 filter choke has been designed for use in class-D field time bases. It can be used in conjunction with the TDA2600 in both 90° and 110° colour television receivers.

MECHANICAL DATA

Dimensions in mm

The magnetic circuit of the choke comprises two Ferroxcube U-cores. The unit is provided with pins for mounting on a printed-wiring board.

Outlines

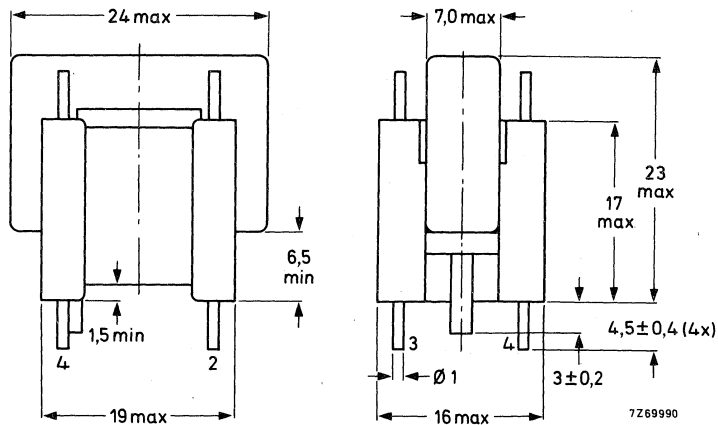

Mounting

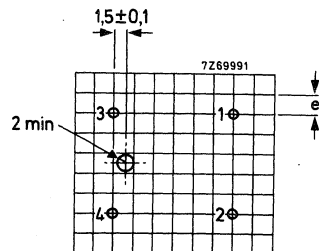

Hole pattern for mounting on a printed-wiring board (component side).

Hole diameter $1,3 \pm 0,1$ mm.
 $e = 2,54$ mm (0,1 in).

ELECTRICAL DATA

Inductance	(1 - 2)	220 μ H \pm 12%
Resistance	(1 - 2)	0,15 Ω
Maximum peak-to-peak current		3,6 A
Maximum working temperature		100 $^{\circ}$ C

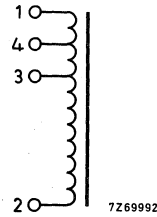

APPLICATION CIRCUIT

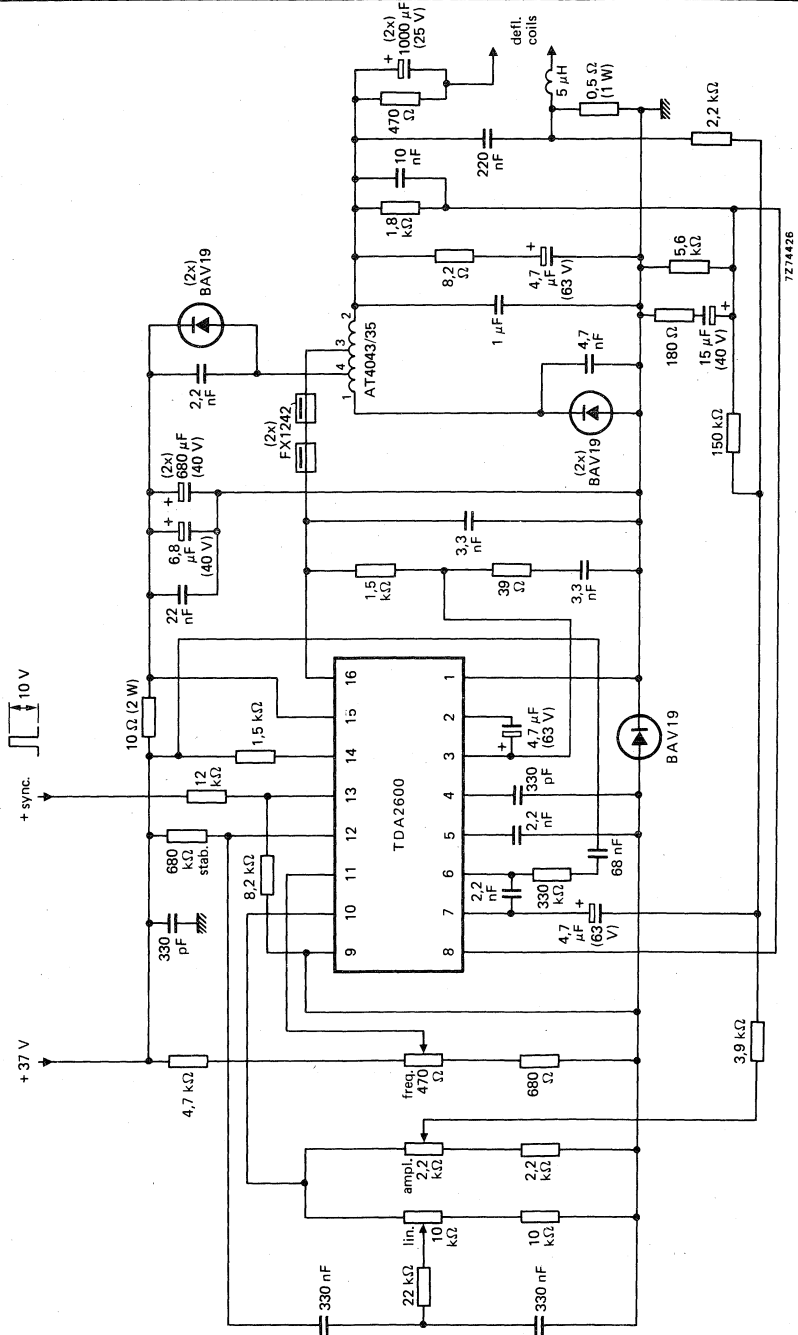

BRIDGE COIL

APPLICATION

This correction coil has been developed to be used as a bridge transformer in the line output transformer circuitry of the AT2080/10 in conjunction with the deflection unit AT1080 (see also data sheet of the AT2080/10).

MECHANICAL DATA

The magnetic circuit of the coil comprises two Ferroxcube U-cores. The unit is provided with pins for mounting on a printed-wiring board.

Dimensions (mm)

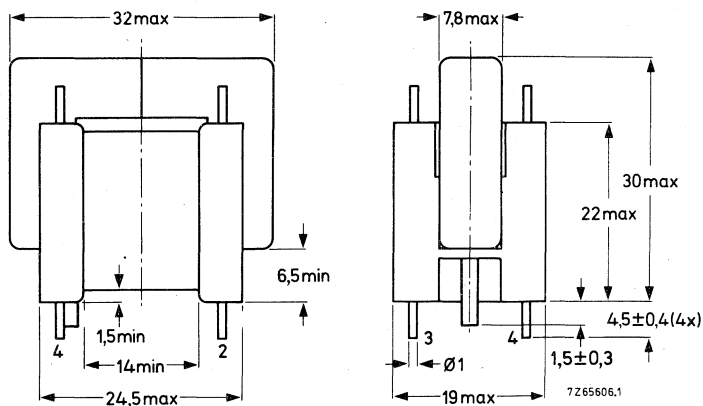

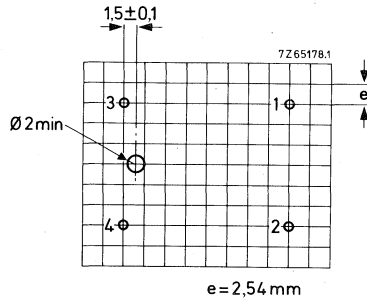

Hole pattern for mounting on a printed-wiring board. Hole diameter 1,3 + 0,1 mm. e = 2,54 mm (0,1 in).

ELECTRICAL DATA

Inductance	425 μ H \pm 10%
Resistance (primary, 1-2)	< 0,4 Ω
Maximum voltage, peak-to-peak	400 V
Maximum current, peak-to-peak	6,7 A
Maximum current, r. m. s.	1,8 A
Maximum working temperature	100 $^{\circ}$ C

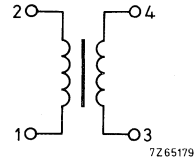

BRIDGE COIL

A55126-2

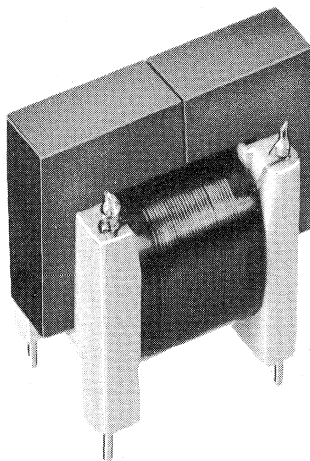

APPLICATION

The bridge coil AT 4043/86 is intended for use in the single-transistor (BU108) line-output circuit for the 110° deflection angle colour television tube A66-140X.

MECHANICAL DATA

The magnetic circuit of the bridge coil comprises two ferroxcube U-cores. The coil is provided with pins for mounting on a printed-wiring board.

Dimensions in mm

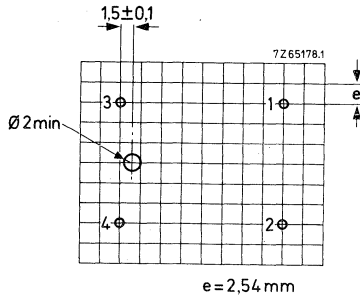
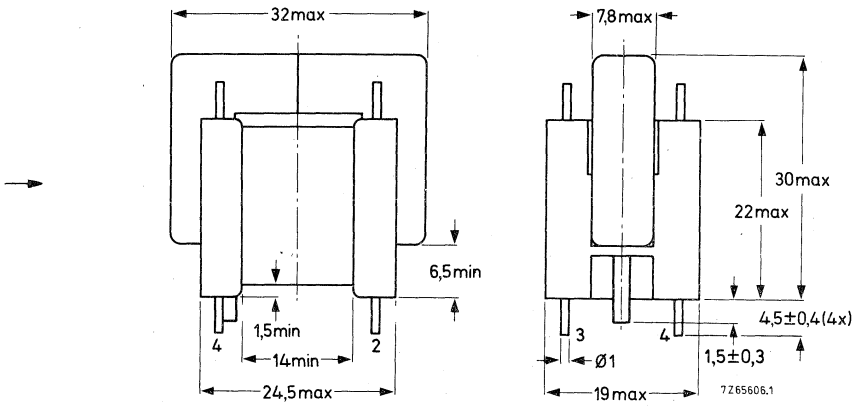

Hole pattern for mounting on a printed-wiring board. Hole diameter 1,3 + 0,1 mm. $e = 2,54 \text{ mm}$ (0,1 in).

ELECTRICAL DATA

Inductance	285 $\mu\text{H} \pm 10 \%$
Resistance (primary, 3-4)	< 0,2 Ω
Maximum voltage, peak-to-peak	350 V
Maximum current, peak-to-peak	6 A
Maximum current, r.m.s.	1,75 A
Maximum working temperature	100 $^{\circ}\text{C}$

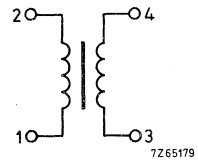

LINE DRIVER TRANSFORMER

APPLICATION

The transformer AT4043/87 has been designed for all-transistor black/white and colour television sets. In black and white television sets it can be used in the single-transistor (BU205) line-output circuit in conjunction with the line-output transformer AT2048/12; in colour television sets it can be used in the single-transistor (BU208) line-output circuit in conjunction with the line-output transformer AT2063/...

MECHANICAL DATA

Dimensions in mm

The magnetic circuit of the transformer comprises two Ferroxcube U-cores. The unit is provided with pins for mounting on a printed-wiring board.

Outlines

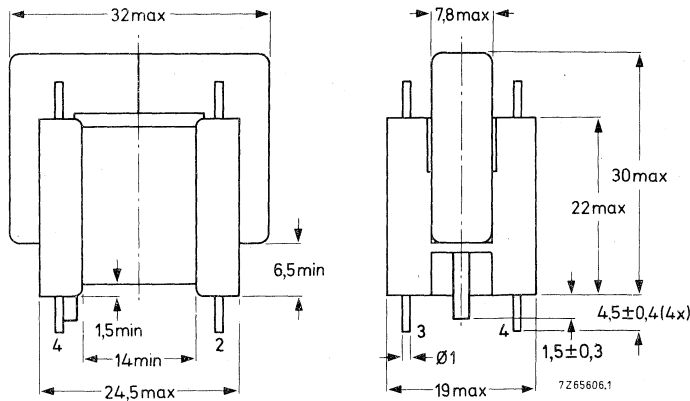

Mounting

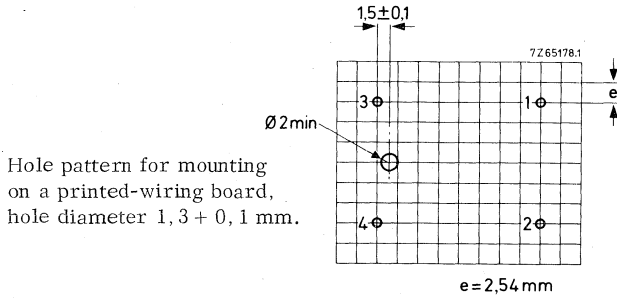

ELECTRICAL DATA

Inductance (primary, 1-4)	76 mH \pm 12%
Leakage inductance (secondary)*)	$\leq 2,0 \mu$ H
Transformation ratio	29: 1
Maximum working temperature	100 °C

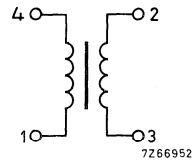

*) Primary short circuited

LINE CENTRING CHOKE

APPLICATION

The coil AT4043/88 is intended for use in the single-transistor (BU 208) line-output circuit ; for circuit diagram see data on line-output transformer AT 2063/...

MECHANICAL DATA

The magnetic circuit of the line centring choke comprises two ferroxcube U-cores. The coil is provided with pins for mounting on a printed-wiring board.

Dimensions (mm)

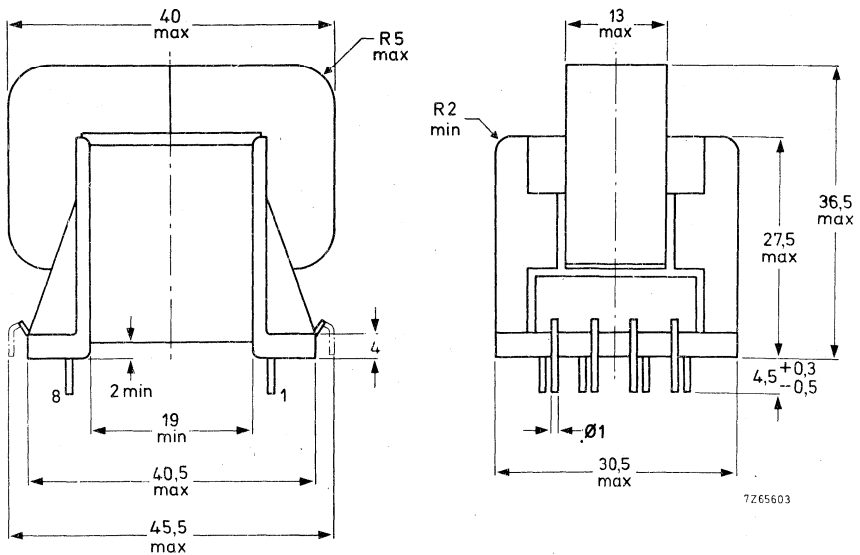

Mounting

Hole pattern (viewed from printed-wiring side) for mounting on a printed-wiring board, hole diameter $1,3 + 0,1$ mm.

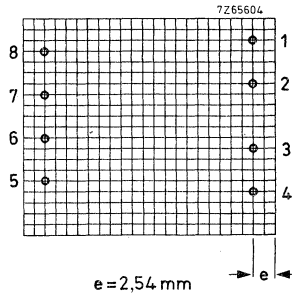

ELECTRICAL DATA

Inductance (primary, 1-5)	52,5 mH $\pm 10\%$
Resistance (primary, 1-5)	6,1 Ω $\pm 10\%$
Nominal current, peak to peak	140 mA
Transformation ratio	20 : 1
Maximum working temperature	100 °C

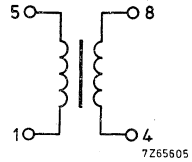

E/W LOADING COIL

APPLICATION

This coil has been designed for the circuitry around the line output transformer AT 2080/10 in conjunction with the deflection unit AT 1080 (see also the data on the transformer).

MECHANICAL DATA

Dimensions (mm)

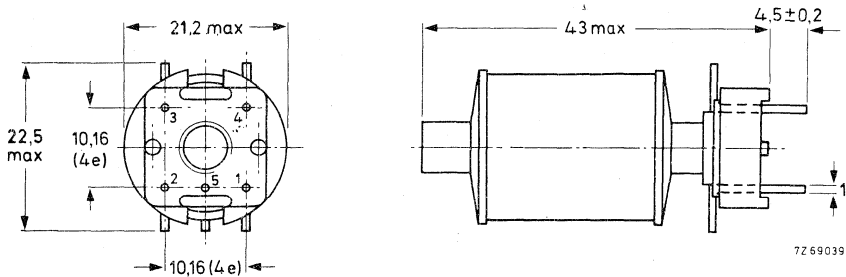

Fig. 1.

The coil is provided with pins for mounting on a printed-wiring board. It can be adjusted at the top by means of a trimming key.

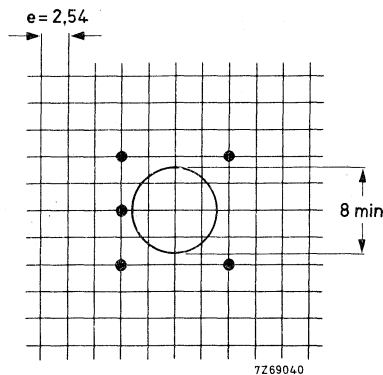

Fig. 2 Hole pattern for mounting on a printed-wiring board, hole dia $1,3 + 0,1$ mm

ELECTRICAL DATA

Inductance between 3 and 4	*)	1 to 5,3 mH
Resistance between 3 and 4		2 Ω
Maximum working temperature		95 $^{\circ}\text{C}$

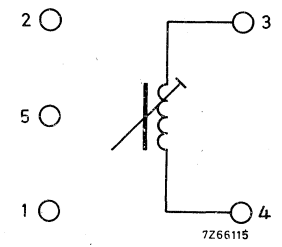

Fig.3 Connection diagram

*) measured with 5000 pF in parallel.

LINE BALANCE COIL

APPLICATION

This coil has been designed for the circuitry of the four-pole unit incorporated in the deflection unit AT1080, for equalization of line and field astigmatism (see also data on AT1080)

MECHANICAL DATA

Dimensions (mm)

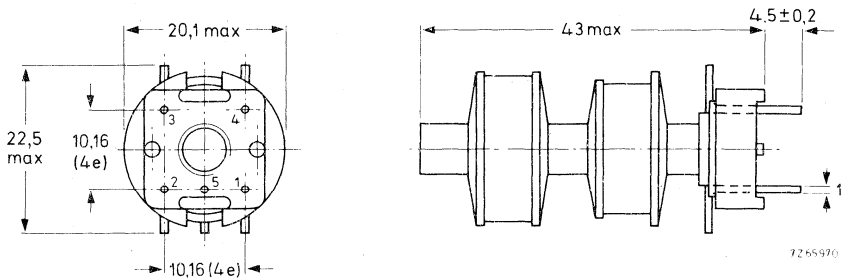

Fig. 1

The coil is provided with pins for mounting on a printed-wiring board. It can be adjusted at the top by means of a trimming key.

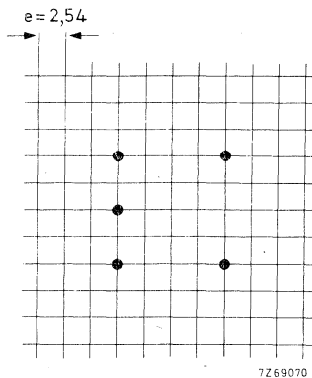

Fig. 2 Hole pattern for mounting on a printed-wiring board, hole dia $1,3 \pm 0,1$ mm

ELECTRICAL DATA

Inductance between 4 and 1	*)	110 to 30 μ H
between 2 and 3		30 to 110 μ H
Resistance between 4 and 1, and 2 and 3		0, 23 Ω
Maximum working temperature		95 $^{\circ}$ C

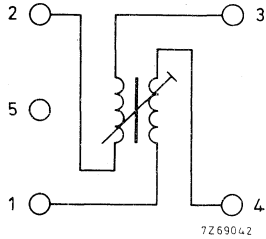

Fig.3 Connection diagram

Pins 2 and 4 should be interconnected.

*) measured with 5000 pF in parallel.

FOUR-POLE ADJUSTING COIL

APPLICATION

This correction coil has been designed for the circuitry of the four-pole unit incorporated in the deflection unit AT1080, for equalization of line astigmatism (see also data on AT1080).

MECHANICAL DATA

Dimensions (mm)

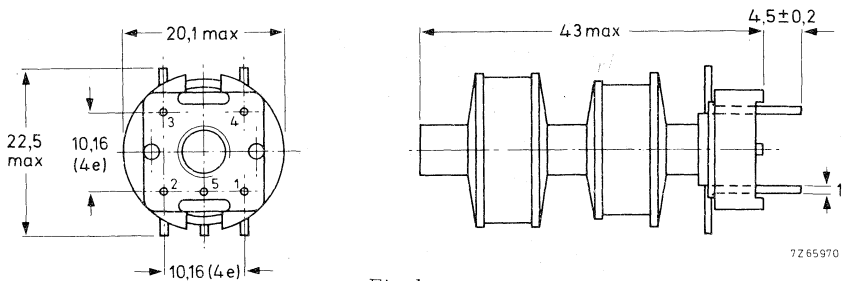

Fig. 1

The coil is provided with pins for mounting on a printed-wiring board. It can be adjusted at the top by means of a trimming key.

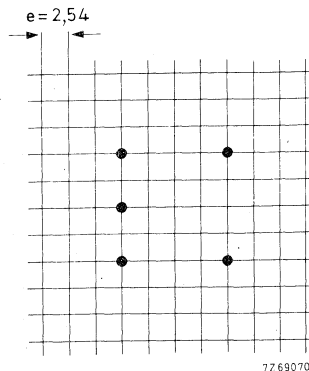

Fig. 2 Hole pattern for mounting on a printed-wiring board, hole dia $1,3 \pm 0,1$ mm

ELECTRICAL DATA

Inductance, measured with 5000 pF in parallel

between 3 and 5	*)	33 to 150 μH
between 4 and 5	*)	150 to 33 μH

Resistance at 25 °C

between 1 and 2	0,23 Ω
between 3 and 4	0,18 Ω

Maximum working temperature 95 °C

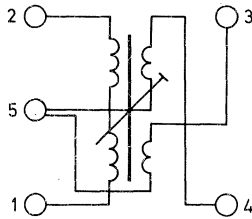

7Z69271

Fig. 3. Connection diagram

*) Supplied with core position for $L_{3-5} = L_{5-4} = 11,3 \mu\text{H} \pm 5\%$.

CONVERGENCE UNITS

APPLICATION

These units are intended to be used with a 90° or 110° shadow mask colour picture tube in conjunction with the deflection unit AT1027/..

or AT1060/..

or AT1062/..

or AT1063/..

MECHANICAL DATA

Dimensions (mm)

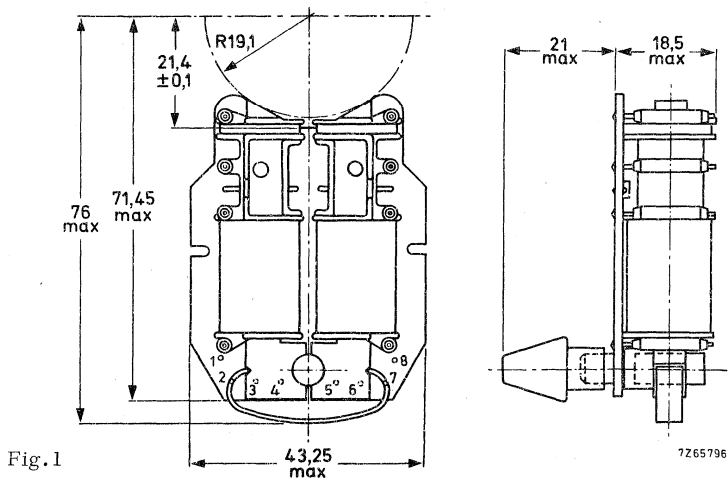

Mounting

The housing of the deflection unit AT1027/.. is so constructed that the convergence units can easily slide in and then, after they have been properly pushed back, lock.

The units have to be put into the housing with the printed wiring up. To take out the units the locks must be released; this can be done by pushing a screwdriver or the like between each unit and the housing.

ELECTRICAL DATA

The units have 4 coils, two for horizontal deflection and two for vertical deflection. They are mounted on a printed-wiring board. The coils can be connected by soldering to the printed-wiring pads. The units are provided with a permanent magnet for static convergence with which a shift of $\pm >20$ mm can be obtained on 90° picture tubes, and $\pm >12$ mm on 110° picture tubes.

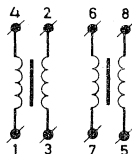

Fig. 2

Series connected line coils

AT4046/27

AT4046/28

Inductance	0,4 mH	4,9 mH
Resistance	2 Ω	22,6 Ω
Connecting tags	3 and 7	3 and 7
Tags to be interconnected	2 and 6	2 and 6

Parallel connected line coils

Inductance	0,1 mH	1,2 mH
Resistance	0,5 Ω	5,5 Ω
Connecting tags	2 and 3	2 and 3
Tags to be interconnected	2 and 7, 3 and 6	2 and 7, 3 and 6

Series connected field coils

Inductance	1,44 H	1,44 H
Resistance	194 Ω	194 Ω
Connecting tags	1 and 5	1 and 5
Tags to be interconnected	4 and 8	4 and 8

Parallel connected field coils

Inductance	0,36 H	0,36 H
Resistance	48,5 Ω	48,5 Ω
Connecting tags	1 and 4	1 and 4
Tags to be interconnected	1 and 8, 4 and 5	1 and 8, 4 and 5

CONVERGENCE UNIT

APPLICATION

These units are intended to be used with a 90° or 110° shadow mask colour picture tube in conjunction with the deflection unit AT1027/..
 or AT1060/..
 or AT1062/..
 or AT1063/..

MECHANICAL DATA

Dimensions (mm)

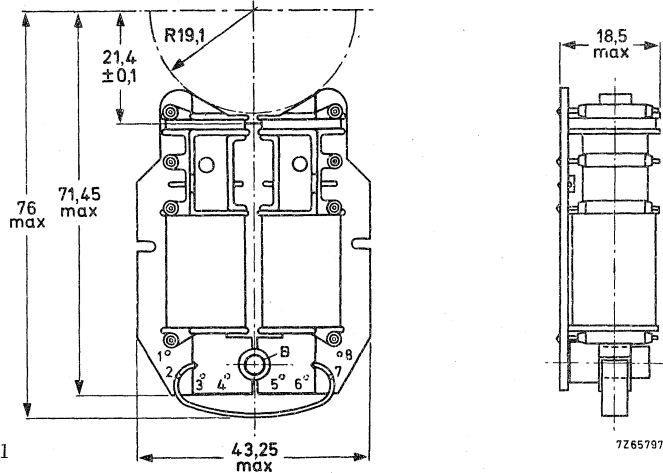

Fig.1

Mounting

The housing of the deflection unit AT1027/.. is so constructed that the convergence units can easily slide in and then, after they have been properly pushed back, lock. The units have to be put into the housing with the printed wiring up. To take out the units the locks must be released; this can be done by pushing a screwdriver or the like between each unit and the housing.

ELECTRICAL DATA

The units have 4 coils, two for horizontal and two for vertical deflection. They are mounted on a printed-wiring board. The coils can be connected by soldering to the printed-wiring pads. The unit is provided with a plastic bush B (see Fig.1) to accommodate the permanent magnet *) for rough static adjustment. Fine adjustment can be made with a d. c. current.

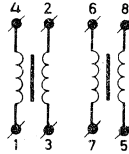

Fig.2

Series connected line coils

Inductance	4,9 mH
Resistance	22,6 Ω
Connecting tags	3 and 7
Tags to be interconnected	2 and 6

Parallel connected line coils

Inductance	1,2 mH
Resistance	5,5 Ω
Connecting tags	2 and 3
Tags to be interconnected	2 and 7, 3 and 6

Series connected field coils

Inductance	1,44 H
Resistance	194 Ω
Connecting tags	1 and 5
Tags to be interconnected	4 and 8

Parallel connected field coils

Inductance	0,36 H
Resistance	48,5 Ω
Connecting tags	1 and 4
Tags to be interconnected	1 and 8, 4 and 5

*) Separately available under catalogue number 4312 020 70201.

DELAY LINE

QUICK REFERENCE DATA

For receivers up to European PAL standard

Nominal frequency 4,433619 MHz

Phase delay time 63,943 μ s

Dimensions 71 x 7,5 x 37,5 mm

Self-extinguishing properties

APPLICATION

The DL50 is intended for use in decoder circuits of colour television receivers.

DESCRIPTION

A very thin slab of zero TC glass provided with two transducers is mounted shock proof in a housing, that satisfies the flame test described in IEC 50 C (secretariat) 11. Six pins enable the unit to be soldered directly into a printed-wiring board.



MECHANICAL DATA

Dimensions (mm)

Fig.1



7265314.1

Weight 16 gMounting

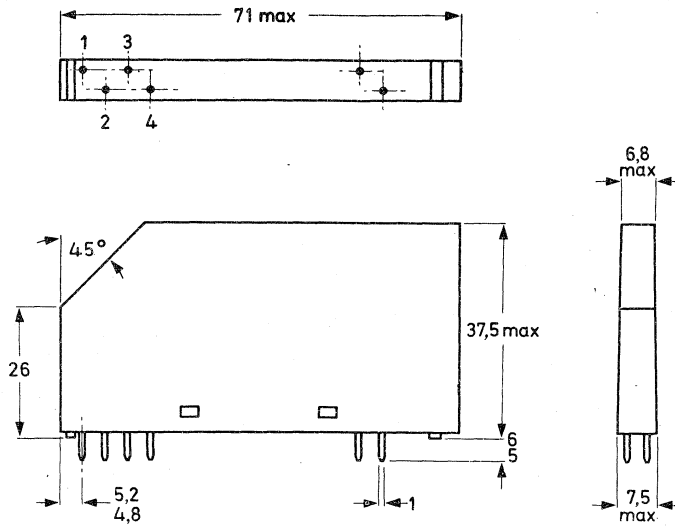
The unit can be soldered directly into a printed-wiring board.

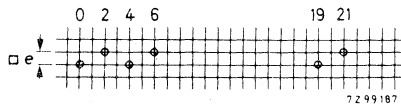

Fig. 2.

Recommended hole pattern for mounting on a printed-wiring board.
 $e = 2,54$ mm. The tolerance on the distances of the different holes to the 0-line is $\pm 0,1$ mm. Hole diameter is $1,3 \pm 0,1$ mm.

ELECTRICAL DATA

Measured according to the circuit of Fig. 3 at 25 °C and f_{nom} (unless otherwise specified)

Nominal frequency (f_{nom})	4,433619 MHz
Phase delay time (τ) between V_1 and V_2 (unmodulated sinewave voltage)	63,943 ± 0,005 μ s
Bandwidth at -3 dB	from ≤ 3,43 to ≥ 5,23 MHz
Insertion loss	8 ± 3 dB
Drift of phase delay from +10 to +60 °C (relative to 25 °C)	max. 5 ns, typ. 3 ns
Maximum input voltage (p-p)	15 V
Unwanted reflections, 3 τ other reflections	≤ -22 dB with respect to 1 τ signal ≤ -30 dB with respect to 1 τ signal
Phase relation $\varphi_{4-3} - \varphi_{2-1}$	180°
Storage temperature range	-40 to +70 °C

Measuring circuit

Fig. 3

Nominal terminations

R1, R2 termination resistance	390 Ω
C1 total capacitance	120 pF
L1 inductive reactance	128 Ω
L2 inductive reactance	231 Ω
Recommended adjustment range of the coils	-19 to +36%
Maximum capacitance of the coils	20 pF

DELAY LINES

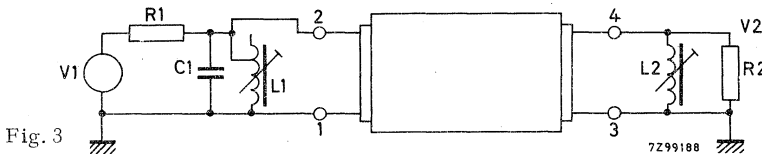
For DESCRIPTION and MECHANICAL DATA see datasheet of type DL50.



ELECTRICAL DATA , measured according to the circuit diagram below at 25 °C and at f_{nom} (unless otherwise stated)

Type number	DL51	DL52	DL53	DL55
Catalogue number	4322 026 95510	4322 026 95520	4322 026 95530	4322 026 95550
Application	European PAL/SECAM	—	Brazilian PAL	NTSC
Nominal frequency (f_{nom})	4, 433619	3, 582063	3, 575611	3, 579545
Phase delay time (τ) between V_1 and V_2 (unmodulated sinewave voltage)	63, 943 ± 0, 005	63, 929 ± 0, 005	63, 486 ± 0, 005	63, 555 ± 0, 005
Bandwidth at -3 dB	≤ 3, 43 to ≥ 5, 23	≤ 2, 7 to ≥ 4, 4	≤ 2, 7 to ≥ 4, 4	≤ 2, 7 to ≥ 4, 4
Insertion loss	8 ± 3	8 ± 3	8 ± 3	8 ± 3
Drift of phase delay from +10 to +60 °C (relative to 25 °C)	max. 5 typ. 3	max. 5 typ. 3	max. 5 typ. .3	max. 5 typ. .3
Maximum input voltage (p-p)	15	15	15	15
Unwanted reflections, 3 τ	≤ -22	≤ -22	≤ -22	≤ -22
other reflections	≤ -35	≤ -30	≤ -30	≤ -30
Phase relation $\phi_{4-3} - \phi_{2-1}$	180	0	0	180
Storage temperature range	-40 to +70	-40 to +70	-40 to +70	-40 to +70

*) measured between 3, 9 and 4, 75 MHz.

Measuring circuit

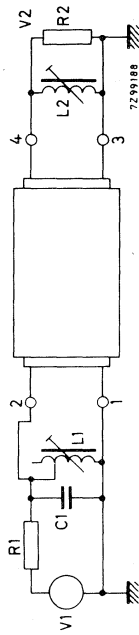

	DL51	DL52	DL53	DL55
Nominal terminations				
R1, R2 termination resistance	390 Ω	560	560	560
C1 total capacitance	120 pF	22	22	22
L1 inductive resistance	128 Ω	337	337	337
L2 inductive reactance	231 Ω	405	405	405
Recommended adjustment range of the coils	-19 to +36 %	-20 to +33	-20 to +33	-20 to +33
Maximum capacitance of the coils	20 pF	20	20	20



DELAY LINE

QUICK REFERENCE DATA

For receivers up to European PAL standard

Nominal frequency 4,433619 MHz

Phase delay time 63,943 μ s

Dimensions 37 x 7,5 x 28,5 mm

Self-extinguishing properties

APPLICATION

The DL60 is intended for use in decoder circuits of colour television receivers.

DESCRIPTION

A very thin slab of zero TC glass provided with two transducers is shock-proof mounted in a housing that satisfies the flame test described in IEC 50 C (secretariat) 11.

Four pins enable the unit to be soldered directly onto a printed-wiring board.



MECHANICAL DATA

Dimensions in mm

Outlines

Fig. 1

Mass

7 g

Mounting

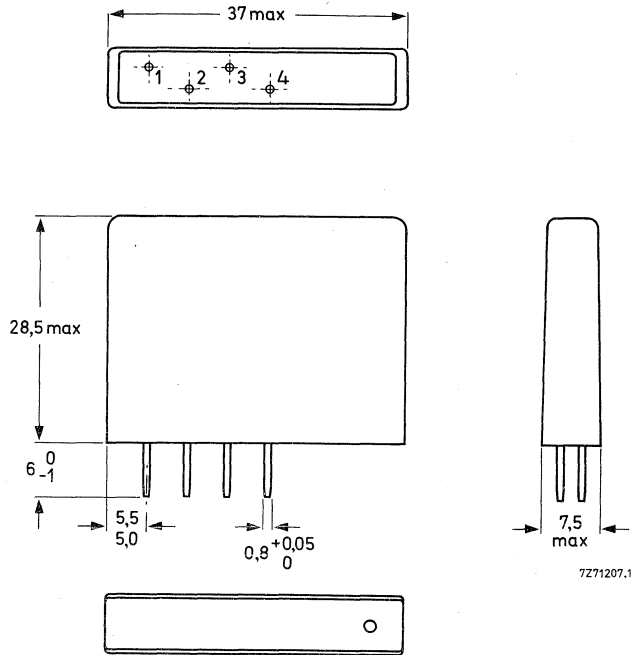
The unit can be soldered directly onto a printed-wiring board.

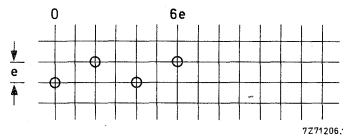

Fig. 2.

Recommended hole pattern for mounting on a printed-wiring board: $e = 2,54$ mm.
 The tolerance on the distances of the different holes to the 0-line is $\pm 0,1$ mm.
 Hole diameter is $1,0 + 0,1$ mm.

ELECTRICAL DATA

Measured with the circuit of Fig. 3 at 25 °C and f_0 (unless otherwise specified)

Nominal frequency (f_0)	4,433619 MHz
Phase delay time (τ)	$63,943 \pm 0,005 \mu\text{s}$
Bandwidth at -3 dB	from $\leq 3,43$ to $\geq 5,23$ MHz
Insertion loss	9 ± 3 dB
Drift of phase delay from +10 to +60 °C (relative to +25 °C)	max. 5 ns, typ. 3 ns
Maximum input voltage (p-p)	10 V
Spurious signals	
3 τ signals	≤ -22 dB with respect to 1 τ signal
other signals	≤ -30 dB with respect to 1 τ signal
Phase relation $\varphi_{4-3} - \varphi_{2-1}$	180°
Storage temperature range	-40 to +70 °C

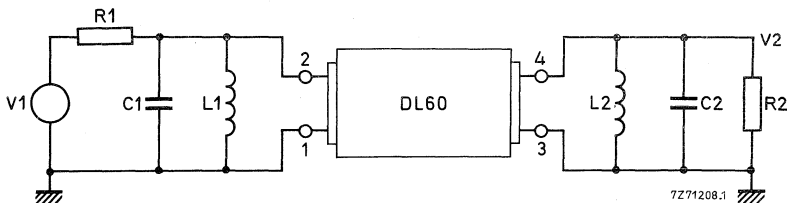

Fig. 3.

Terminations

$$R1 = R2 = 560 \Omega$$

$$C1 = 20 \text{ pF}$$

$$C2 = 30 \text{ pF}$$

$$L1 = 10,5 \mu\text{H}$$

$$L2 = 9,7 \mu\text{H}$$

} total capacitance of test jig without delay-line i. e. wiring capacitance, capacitance of coil and extra trimming capacitor.

Application circuit

Fig. 4

$$(R_L // Z_i) = 560 \Omega$$

C1, C2 < 30 pF (wiring capacitance and capacitance of the coil)

L1, L2 nominal values depend on values of C1 and C2 to produce the reactances :

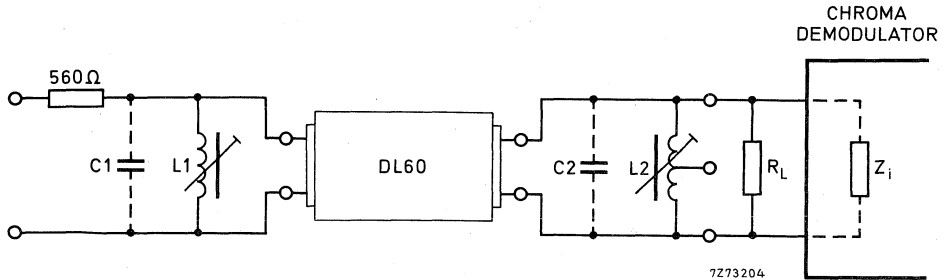
$$X1 = \frac{\omega_0 L1}{1 - \omega_0^2 L1C1} = 350 \Omega$$

$$X2 = \frac{\omega_0 L2}{1 - \omega_0^2 L2C2} = 350 \Omega$$

$$f_0 = 4,433619 \text{ MHz}$$

Maximum bandwidth is obtained at minimum C1 and C2.

Recommended adjustment range of the coils -19 to +36%.

BLUE LATERAL UNITS

Type number Catalogue number	AT1025/05 3122 107 30020	AT1025/08 3122 137 11690	AT1066/01 3122 107 13750
Picture tube	90 °	90 ° and 110 °	90 °
Inductance			
series connected	3,2 mH	-	-
parallel connected	0,63 mH	0,3 mH	2,81 mH
Resistance			
series connected	36 Ω	-	-
parallel connected	9 Ω	3,2 Ω	6,4 Ω
Adjustment range			
static (with magnet)	6,5 mm	6,5 mm	6,5 mm
dynamic	3,5 mm at 350 mA per coil	3,5 mm at 550 mA per coil	3,5 mm at 300 mA per coil



DEFLECTION UNITS

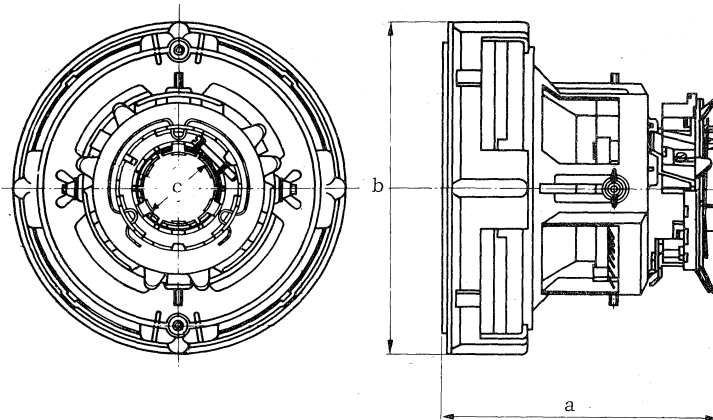

type	dimensions (mm)		
	a _{max}	b _{max}	c _{min}
AT1027/07	145,7	172,3	38,2
AT1027/09	145,7	172,3	38,2
AT1029/07	145,7	172,3	38,2
AT1029/09	145,7	172,3	38,2
AT1060/01	129,4	203,9	38,2

NON-PREFERRED TYPES

DEFLECTION UNITS

	type number and catalogue number				
	AT1027/07 3122 137 10990	AT1027/09 3122 107 31520	AT1029/07 3122 108 87890	AT1029/09 3122 108 87900	AT1060/01 3122 137 10670
Inductance line deflection coils field deflection coils	2, 95 114	2, 95 28	2, 95 114	2, 95 28	4, 4 25, 4
Resistance line deflection coils field deflection coils	2, 9 56	2, 9 14	2, 9 56	2, 9 14	3, 4 15
NTC thermistor	50	6	50	6	8
Parallel resistor	33	12	33	12	-
E.H.T.	25	25	25	25	25
Sensitivity in horizontal direction in vertical direction	2, 6 0, 415	2, 6 0, 83	2, 6 0, 415	2, 6 0, 83	3, 3 1, 2
To be used with: picture tube	22 in, 90° 26 in, 90°	22 in, 90° 26 in, 90°	19 in, 90° 22 in, 90°	19 in, 90° 22 in, 90°	22 in, 110° 26 in, 110°
line-output transformer	AT2053/02	AT2053/02	AT2053/02	AT2053/02	AT2100/04 and AT2101/02
adjustable linearity control unit	AT4042/12	AT4042/12	AT4042/12	AT4042/12	AT4042/12
convergence units	AT4045/.. AT4046/..	AT4045/.. AT4046/..	AT4045/.. AT4046/..	AT4045/.. AT4046/..	AT4045/.. AT4046/..

Terminal location

AT1027/07
 AT1027/09
 AT1029/07
 AT1029/09

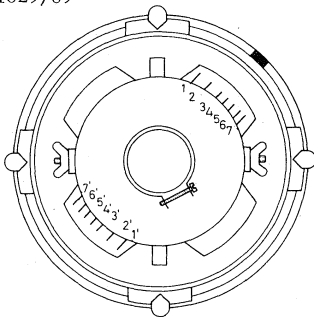

Rear view

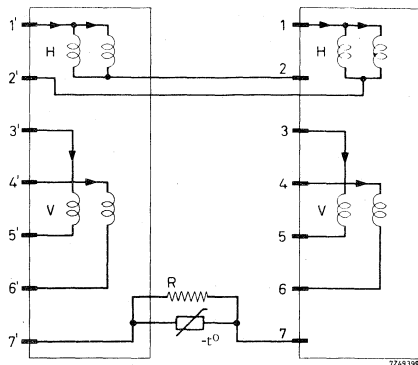

Diagram

AT1060/01

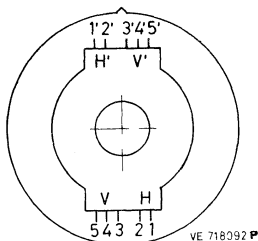

Rear view

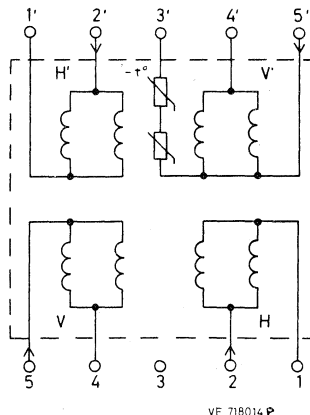

Diagram

H = line coils
 V = field coils

TRANSDUCTORS

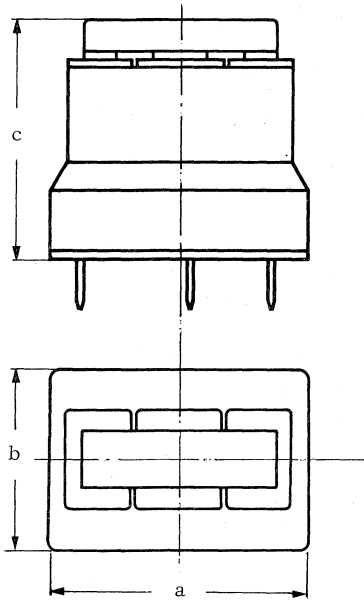

type	max. dimensions (mm)			catalogue number
	a	b	c	
AT4041/08	32,5	21,5	30,2	3122 107 13420
AT4041/14	32,5	21,5	28	3122 137 10530
AT4041/15	32,5	21,5	28	3122 137 10540
AT4041/37	32,5	21,5	30,2	3122 137 12210

The AT4041/08 and the AT4041/37 are intended for use in conjunction with deflection unit AT1027/.. or AT1029/.., line output transformer AT2053/.., pin-cushion adjustor AT4040/.. and a frame output transformer to correct pin-cushion distortion.

The transducer AT4041/14 is intended for use in conjunction with the deflection unit AT1060/.. and in combination with the transducer AT4041/15, for active E.-W. correction.

Terminal location

Bottom views

Diagrams

AT4041/08
AT4041/37

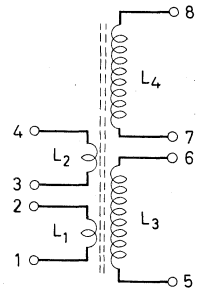
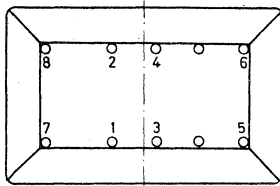

AT4041/14

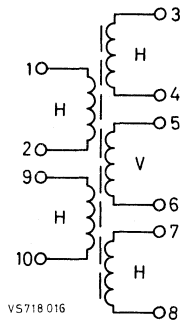
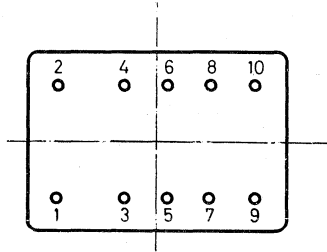

VS718 016

AT4041/15

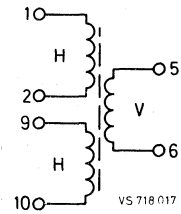
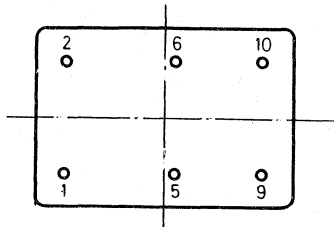

VS 718 017

Circuit diagrams for AT4041/08 and AT4041/37

Deflection units with parallel connected frame coils

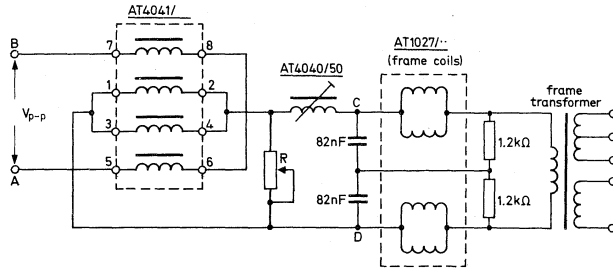

	p-p voltage on	
	BA	CD
AT4041/08	350 V	55 V
AT4041/37	1400 V	55 V

Deflection units with series connected frame coils

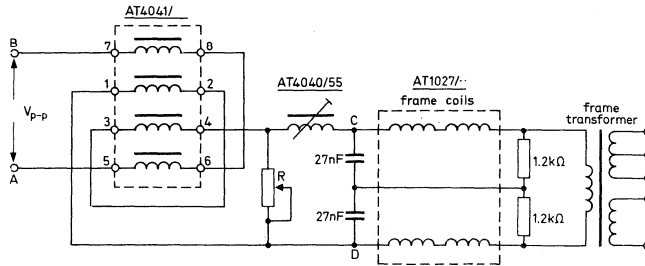

	p-p voltage on	
	BA	CD
AT4041/08	350 V	110 V
AT4041/37	1400 V	110 V

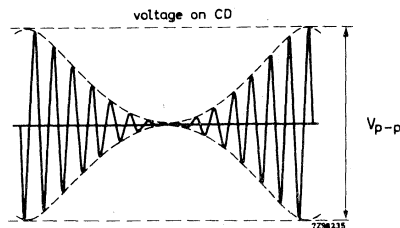

Circuit diagram for AT4041/14

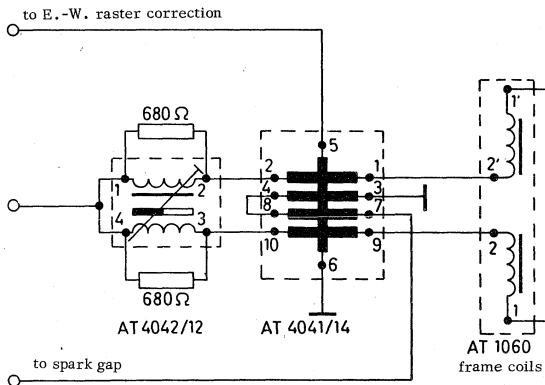

Circuit diagram for AT4041/15

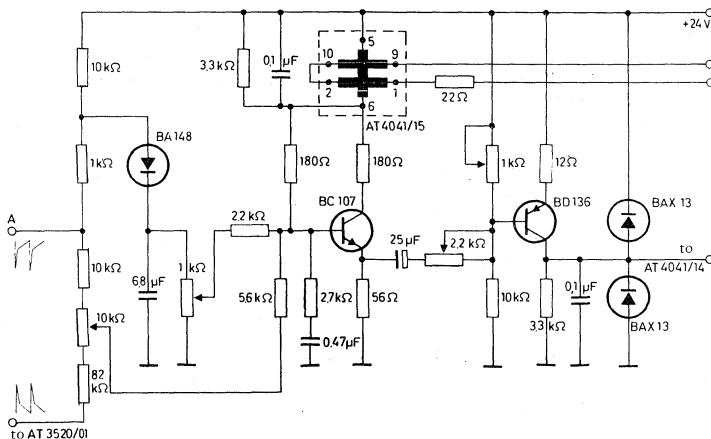

ADJUSTABLE LINEARITY CONTROL UNITS

AT4042/02 , catalogue number 3122 108 28239

This unit is intended to be used in black and white, and in colour TV sets equipped with tubes , to adjust the linearity of the line-deflection. In colour TV sets it can be used in combination with deflection unit AT 1027/.. or AT 1029/.. and line-output transformer AT2050/.. , AT2051/.. or AT2053/.. .

For further information see section "Components for black and white television".

AT4042/12 , catalogue number 3122 138 21281

This unit has been designed for use in colour TV sets equipped with a 110° deflection angle colour picture tube, to adjust the linearity of line deflection. It can be used in combination with the deflection units AT 1060/.. or AT 1062/.. .

Dimensions (mm)

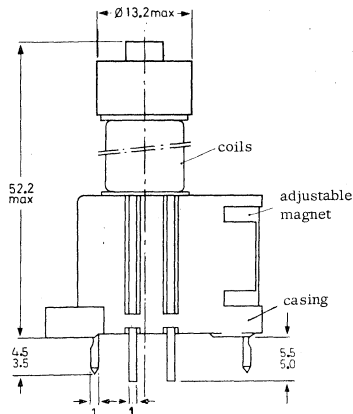
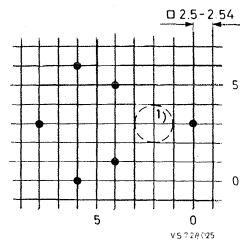
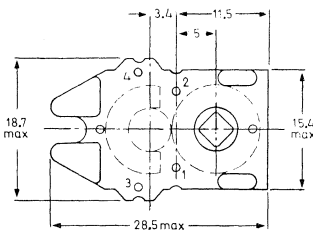

Hole pattern for mounting on a printed-wiring board.
Recommended hole diameter 1,3 mm.

1) Hole only necessary for bottom adjustment.

Electrical data

When a saw-tooth current of a peak-to-peak value of 3.3 A, frequency 15625 Hz, fly-back ratio 18 % (without S- correction) flows through the linearity control unit (coils connected in series, one connection point to earth), the correction voltage is 27 V.

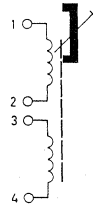

CONVERGENCE UNITS

Type number	AT4045/07	AT4045/08	AT4046/07	AT4046/08	AT4050/11
Catalogue number	3122 108 83130	3122 108 83140	3122 108 83150	3122 108 83160	3122 107 13220
Picture tube	90° and 110°	90° and 110°	90° and 110°	90° and 110°	110°
Line coils, series connected					
inductance	0,4 mH	4,8 mH	0,43 mH	5,2 mH	0,155 mH
resistance	2,5 Ω	22,6 Ω	2,5 Ω	22,6 Ω	1 Ω
parallel connected					
inductance	0,1 mH	1,2 mH	0,11 mH	1,3 mH	
resistance	0,6 Ω	5,7 Ω	0,6 Ω	5,7 Ω	
Field coils, series connected					
inductance	1,40 H	1,40 H	1,48 H	1,52 H	0,66 H
resistance	155 Ω	155 Ω	194 Ω	194 Ω	125 Ω
parallel connected					
inductance	0,35 H	0,35 H	0,37 H	0,38 H	
resistance	39 Ω	39 Ω	49 Ω	49 Ω	
Static coils, series connected					
inductance					60 mH
resistance					34 Ω
Static adjustment	d.c. through frame coils	d.c. through frame coils	with magnet	with magnet	d.c. through static coils



Contents

DATA HANDBOOK SYSTEM

page

F.M. TUNERS

F.M. tuners

AP2157/01	A3
AP2158	A11
FD1	A19
FD1A	A19

LOUDSPEAKERS

Survey

B2

Introduction

B5

Loudspeaker types

AD0140/T.	B17
AD0162/T.	B21
AD0199/Z25	B25
AD0210/Sq.	B29
AD2070/Z.	B33
AD2071/T.	
AD2271/T.	B37
AD2090/T.	
AD2290/T.	B43
AD2099/Z25	B49
AD3070/Y.	
AD3370/Y.	B53
AD3590/X.	B57
AD3880/X.	B61
AD3890/X.	B65
AD4070/Y.	
AD4470/Y.	B69
AD4080/X.	
AD4480/X.	B73
AD4085/X.	
AD4485/X.	B77
AD4090/X.	B81
AD4481/X4	B85
AD4681/M.	B89
AD4681/X.	B93
AD4682/X.	B97
AD4691/M.	B101
AD4691/X.	B105
AD4692/X.	B109
AD4890/X.	B113
AD5060/Sq.	B117
AD5061/M.	B121

		page	
Loudspeaker types	AD5061/Sq.	B125	
	AD5081/M.	B129	
	AD5081/X.	B133	
	AD5780/M.	B137	
	AD5780/X.	B141	
	AD5790/M.	B145	
	AD5790/X.	B149	
	AD6980/M.	B153	
	AD6980/X.	B157	
	AD7060/W.	B161	
	AD7062/M.	B165	
	AD7063/M.	B169	
	AD7066/MFB	B173	
	AD7066/W.	B179	
	AD7080/M.	B183	
	AD7080/X.	B187	
	AD7091/M.	B191	
	AD7091/X.	B195	
	AD8000	B199	
	AD8061/W.	B201	
	AD8066/W.	B205	
	AD8067/MFB	B209	
	AD8067/W.	B215	
	AD8081/M.	B219	
	AD8081/X.	B223	
	9710/MC	B227	
	AD1065/M.	B231	
	AD1065/W.	B235	
	AD10100/W.	B239	
	AD1265/M.	B243	
	AD1265/W.	B247	
	AD12100/HP.	B251	
	AD12100/M.	B255	
	AD12100/W.	B259	
	Cross-over networks	ADF1600	B265
		ADF2400	B267
ADF500/4500		B269	
Recommended loudspeaker combinations		B272	

TELEVISION TUNERS AND AERIAL INPUT ASSEMBLIES

Television tuners	ELC1042/05	C3
	ELC1043/05	C17
	ELC1043/06	C29
	ELC2000	C31
	ELC2060	C49
	ELC2070	C67
	ELC3082	C81

		page
Television tuners	12ET5632	} general
	12ET5732	
	12ET5632/03	C93
	12ET5732/03	C97
Coaxial aerial input assemblies	3122 127 10260	C103
	3122 127 10450	
	3122 127 14730	C109

COMPONENTS FOR BLACK AND WHITE TELEVISION

Survey		D2
Deflection units	AT1040/15	D5
	AT1071/01	D11
	AT1074	D15
Line output transformers	AT2048/12	D21
	AT2102/01	D27
	AT2140	D33
	AT3515	D39
Frame output transformers	AT4036	D45
Adjustable linearity control units	AT4042/14	D49
	AT4043/87	D51
Line driver transformer		D53
Non preferred types, deflection units	line output transformers	D59
	linearity control units	D65
	e. h. t. sockets for tube DY802	D67

COMPONENTS FOR COLOUR TELEVISION

Survey		E2
Deflection units	AT1062/01	E5
	AT1063/01	E11
	AT1068/03	E15
Blue lateral units	AT1068/04	E17
	AT1080	E19
Deflection unit	AT1081	E25
Multi-pole unit	AT1083/01	E31
Deflection units	AT1085	E37
	AT2063/00	E43
	AT2076/10	E49
	AT2080/10	E55
	AT4040/..	E61
Convergence adjusters	AT4040/..	E65
Correction coils	AT4041/40	E69
Transductor	AT4042/08	E73
	AT4042/17	E75
Adjustable linearity control units	AT4042/38	E77
	AT4043/15	E79
	AT4043/35	E81
Filtering coil	AT4043/38	E85
	AT4043/86	E87
Class-D filter choke		
Bridge coils		

		page
Line driver transformer	AT4043/87	E89
Line centring choke	AT4043/88	E91
E/W loading coil	AT4044/20	E93
Line balance coil	AT4044/26	E95
Four-pole adjusting coil	AT4044/27	E97
Convergence units	AT4046/27	E99
	AT4046/28	E99
	AT4046/32	E101
Delay lines	DL50	E103
	DL51/DL52/DL53/DL55	E107
	DL60	E111
Non preferred types, blue lateral units		E115
deflection units		E117
transducers		E121
adjustable linearity control units		E125
convergence units		E127



A FM tuners



B Loudspeakers



C Television tuners and aerial input assemblies



D Components for black and white television



E Components for colour television



Contents

Electronic components and materials for professional, industrial and consumer uses from the world-wide Philips Group of Companies

- Argentina:** FAPESA I.y.C., Av. Crovara 2550, Tablada, Prov. de BUENOS AIRES, Tel. 652-7438/7478.
- Australia:** PHILIPS INDUSTRIES HOLDINGS LTD., Elcoma Division, 67 Mars Road, LANE COVE, 2066, N.S.W., Tel. 42 1261.
- Austria:** ÖSTERREICHISCHE PHILIPS BAUELEMENTE Industrie G.m.b.H., Triester Str. 64, A-1101 WIEN, Tel. 62 91 11.
- Belgium:** M.B.L.E., 80, rue des Deux Gares, B-1070 BRUXELLES, Tel. 523 00 00.
- Brazil:** IBRAPE, Caixa Postal 7383, Av. Paulista 2073-S/Loja, SAO PAULO, SP, Tel. 287-7144.
- Canada:** PHILIPS ELECTRONICS LTD., Electron Devices Div., 601 Milner Ave., SCARBOROUGH, Ontario, M1B 1M8, Tel. 292-5161.
- Chile:** PHILIPS CHILENA S.A., Av. Santa Maria 0760, SANTIAGO, Tel. 39-40 01.
- Colombia:** SADAPE S.A., P.O. Box 9805 Calle 13, No. 51 + 39, BOGOTA D.E. 1., Tel. 600 600.
- Denmark:** MINIWATT A/S, Emdrupvej 115A, DK-2400 KØBENHAVN NV., Tel. (01) 69 16 22.
- Finland:** OY PHILIPS AB, Elcoma Division, Kaivokatu 8, SF-00100 HELSINKI 10, Tel. 1 72 71.
- France:** R.T.C. LA RADIOTECHNIQUE-COMPELEC, 130 Avenue Ledru Rollin, F-75540 PARIS 11, Tel. 355-44-99.
- Germany:** VALVO, UB Bauelemente der Philips G.m.b.H., Valvo Haus, Burchardstrasse 19, D-2 HAMBURG 1, Tel. (040) 3296-1.
- Greece:** PHILIPS S.A. HELLENIQUE, Elcoma Division, 52, Av. Syngrou, ATHENS, Tel. 915 311.
- Hong Kong:** PHILIPS HONG KONG LTD., Comp. Dept., Philips Ind. Bldg., Kung Yip St., K.C.T.L. 289, KWAI SHUNG, N.T. Tel. 12-24 51 21.
- India:** PHILIPS INDIA LTD., Elcoma Div., Band Box House, 254-D, Dr. Annie Besant Rd., Prabhadevi, BOMBAY-25-DD, Tel. 457 311-5.
- Indonesia:** P.T. PHILIPS-RALIN ELECTRONICS, Elcoma Division, 'Timah' Building, Jl. Jen. Gatot Subroto, JAKARTA, Tel. 44 163.
- Ireland:** PHILIPS ELECTRICAL (IRELAND) LTD., Newstead, Clonskeagh, DUBLIN 14, Tel. 69 33 55.
- Italy:** PHILIPS S.P.A., Sezione Elcoma, Piazza IV Novembre 3, I-20124 MILANO, Tel. 2-6994.
- Japan:** NIHON PHILIPS CORP., Shuwa Shinagawa Bldg., 26-33 Takanawa 3-chome, Minato-ku, TOKYO (108), Tel. 448-5611.
(IC Products) SIGNETICS JAPAN, LTD., TOKYO, Tel. (03) 230-1521.
- Korea:** PHILIPS ELECTRONICS (KOREA) LTD., Philips House, 260-199 Itaewon-dong, Yongsan-ku, C.P.O. Box 3680, SEOUL, Tel. 44-4202.
- Mexico:** ELECTRONICA S.A. de C.V., Varsovia No. 36, MEXICO 6, D.F., Tel. 5-33-11-80.
- Netherlands:** PHILIPS NEDERLAND B.V., Afd. Elconco, Boschdijk 525, NL-4510 EINDHOVEN, Tel. (040) 79 33 33.
- New Zealand:** Philips Electrical Ind. Ltd., Elcoma Division, 70-72 Kingsford Smith Street, WELLINGTON, Tel. 873 156.
- Norway:** ELECTRONICA A/S., Vitamineveien 11, P.O. Box 29, Grefsen, OSLO 4, Tel. (02) 15 05 90.
- Peru:** CADESA, Jr. Ilo, No. 216, Apartado 10132, LIMA, Tel. 27 73 17.
- Philippines:** ELDAC, Philips Industrial Dev. Inc., 2246 Pasong Tamo, MAKATI-RIZAL, Tel. 86-89-51 to 59.
- Portugal:** PHILIPS PORTUGESA S.A.R.L., Av. Eng. Duharte Pacheco 6, LISBOA 1, Tel. 68 31 21.
- Singapore:** PHILIPS SINGAPORE PTE LTD., Elcoma Div., POB 340, Toa Payoh CPO, Lorong 1, Toa Payoh, SINGAPORE 12, Tel. 53 88 11.
- South Africa:** EDAC (Pty.) Ltd., South Park Lane, New Doornfontein, JOHANNESBURG 2001, Tel. 24/6701.
- Spain:** COPRESA S.A., Balmes 22, BARCELONA 7, Tel. 301 63 12.
- Sweden:** A. B. ELCOMA, Lidingsvägen 50, S-10 250 STOCKHOLM 27, Tel. 08/67 97 80.
- Switzerland:** PHILIPS A.G., Elcoma Dept., Edenstrasse 20, CH-8027 ZÜRICH, Tel. 01/44 22 11.
- Taiwan:** PHILIPS TAIWAN LTD., 3rd Fl., San Min Building, 57-1, Chung Shan N. Rd, Section 2, P.O. Box 22978, TAIPEI, Tel. 5513101-5.
- Turkey:** TÜRK PHILIPS TICARET A.S., EMET Department, Gümüssuyu Cad. 78-80, Beyoğlu, ISTANBUL, Tel. 45 32 50.
- United Kingdom:** MULLARD LTD., Mullard House, Torrington Place, LONDON WC1E 7HD, Tel. 01-580 6633.
- United States:** (Active devices & Materials) AMPEREX SALES CORP., 230, Duffy Avenue, HICKSVILLE, N.Y. 11802, Tel. (516) 931-6200.
(Passive devices) MEPCO/ELECTRA INC., Columbia Rd., MORRISTOWN, N.J. 07960, Tel. (201) 539-2000.
(IC Products) SIGNETICS CORPORATION, 811 East Arques Avenue, SUNNYVALE, California 94086, Tel. (408) 739-7700.
- Uruguay:** LUZILETRON S.A., Rondeau 1567, piso 5, MONTEVIDEO, Tel. 9 43 21.
- Venezuela:** IND. VENEZOLANAS PHILIPS S.A., Elcoma Dept., A. Ppal de los Ruices, Edif. Centro Colgate, Apdo 1167, CARACAS, Tel. 36 05 11.